



Engine power

At flywheel: **90 Hp/DIN**

Operating weight

With "Supercomfort"* cab, including fluids: **3,970 kg**

* Optional

Engine

Fiat 8055.05
 Direct injection Diesel
 Number of cylinders: 5
 Bore and stroke: 104 × 115 mm
 Piston displacement: 4,885 cc
 Rpm at max power: 2,500
 Distributor-type injection pump
 Air cleaner: oil bath, with centrifugal pre-cleaner
 Vertical exhaust muffler

Clutch

— Transmission: single-plate, dry-type
 — P.t.o.: single plate, dry-type, with separate control

Speeds (kph)

With tyres:	18.4/15-34
Engine (rpm)	2,500
With gearbox:	15 + 3 or 20 + 4 *
FORWARD	
1st creeper*	0.3
2nd creeper*	0.4
3rd creeper*	0.6
4th creeper*	0.7
5th creeper*	0.9
1st low	1.1
2nd low	1.3
3rd low	1.8
4th low	2.3
5th low	2.9
1st medium	3.3
2nd medium	4.4
3rd medium	5.8
4th medium	7.3
5th medium	9.1
1st high	10.5
2nd high	14.0
3rd high	18.5
4th high	23.1
5th high	29.0 ÷ *32.89
REVERSE	
1st creeper*	0.4
1st low	1.3
1st medium	4.3
1st high	13.9

* With creeper speed reduction gear
 * Effective speed with max tyre size supplied
 * Optional

Transmission

Gearbox: 15F + 3R speeds, fully synchronized (including reverse speeds)
 Differential with mechanically operated lock and automatic disconnection with hydrostatic control
 Planetary-type final drives

Brakes

Service: disc-type, oil-bath, with hydrostatic control
 Parking: disc-type, fully independent, with hand control lever

Front axle

Centre-mounted differential with "NO-SPIN" automatic lock device*
 Planetary-type final drives

* Optional

Steering

Hydrostatic type with independent circuit
 Steering wheel adjustable on height and rake

Power take-off

Fully independent:
 1 3/8" - 6 spline shaft
 540 rpm and proportional ground speed

Tyres (pairing of tyres)

Front: 14.9/13-24
 Rear : 18.4/15-34 or 16.9/14-38*

* Optional

Hydraulic lift

With draft, position and mixed control
Draft control through lower links and flexion bar

Pump capacity: 44 l/min
Relief valve opening pressure:
190 kg/sq.cm.

Lift control accessible from ground
New automatic quick lifting or lowering links device (Lift-o-matic) Fiat Trattori design.

Response control and links lowering speed adjustment (Vario-speed)

3-point linkage, Cat. 2

Vertical tie-rods with U-joints

Right vertical tie-rod adjustment operated from driver's compartment

Lower links with telescopic ends and telescopic sway restrictors or "Heavy duty" tipe with quick couplings and spacing spring*

Lifting capacity: 3,630 kg

With 1 auxiliary cylinder*: 4,537 kg

* Optional

Electrical system

Voltage: 12 V

Alternator: 780 Watt

Battery: 132/140 Ah

Starter safety switch

Cold starting aid: thermostart or start-pilote*

Two-position headlamps

Parking, direction, stop and emergency lights

New multi-function instrument panel with "Check controls"

Rear flood light

* Optional

Driver's compartment

Modular platform with integral structure, fully suspended

Adjustable, upholstered operator's seat with parallelogram suspension and hydraulic shock absorber

Body

Square shaped hood with removable side covers for max accessibility
Front wheel fenders*

* Optional

Capacities

Fuel tank: 93 l

With 1 auxiliary* tank: 133 l

Engine oil sump and filter: 13.7 l

Rear transmission and hydraulic lift: 45.5 l

* Optional

Optionals

Transmission

Gearbox, fully synchronized, with: 20F + 4R speeds, (with creeper speed reduction gear)

5th speed with differentiated ratio for a max speed of 25 kph

Brakes

With special valve* for hydraulic trailer braking

* Supplied only with auxiliary control valves

Power take-off

1 $\frac{3}{8}$ " - 6 and 21 spline shaft

540/1,000 rpm and proportional ground speed

Rpm per rear wheel revolution

(independently of gear engaged):

17.28 (at 540 rpm);

28.22 (at 1,000 rpm)

1 $\frac{3}{4}$ " - 6 spline shaft

Towing attachments

Front hook

Trailer hitch and support conventional or special type (Rockinger, Lemoine or Piton), supplied in many combinations

Swinging drawbar

Tyres

Front: a) 13.6/12-24

b) 12.4/11-28

Rear : a) 16.9/14-34

b) 16.9/14-38

Rear wheels

With cast discs for tread adjustment through P.A.V.T. device

Hydraulics

Convertible auxiliary control valves (single or double acting) with $\frac{1}{2}$ " halves (push-pull) for quick coupling under pressure, supplied up to 3 in many combinations for implement remote control

Floating position availability

Ballast

Front support with hook

Ballasting on front axle and rear wheels

Supercomfort cab*

Soundproofing, ample glazing, including:

Safety escape hatch; opening rear and side window glasses; doors fully glassed with semi-open-position lock device; windshield washer and wiper; tinted glasses; ventilation and heating system; "Super de-Luxe" adjustable seat with cloth covering, tilting arm-rests and headrest

Optional

Air conditioning; 2 front and 2 auxiliary rear headlights

Comfort cab*

With ample glazing, doors fully glassed, opening rear and side window glasses; ventilation and heating system
Soundproofing

Safety frame*

With roof

* Complies with O.E.C.D. standards

Dimensions

(with 14.9/13-24 and 18.4/15-34 tyres)

A - Wheelbase: 2,420 mm

B - Overall length: 3,851 mm

C - Height to hood: 1,595 mm

D - Height to steering wheel: 1,840 mm

E - Front tread (6 positions): from 1,822 to 2,153 mm

F - Rear tread (7 positions): from 1,600 to 2,200 mm

G - Ground clearance under front axle: 535 mm

H - Ground clearance under front differential: 455 mm

I - Height to exhaust: 2,648 mm

L - Height to cab: 2,598 mm

- Height to safety frame: 2,592 mm

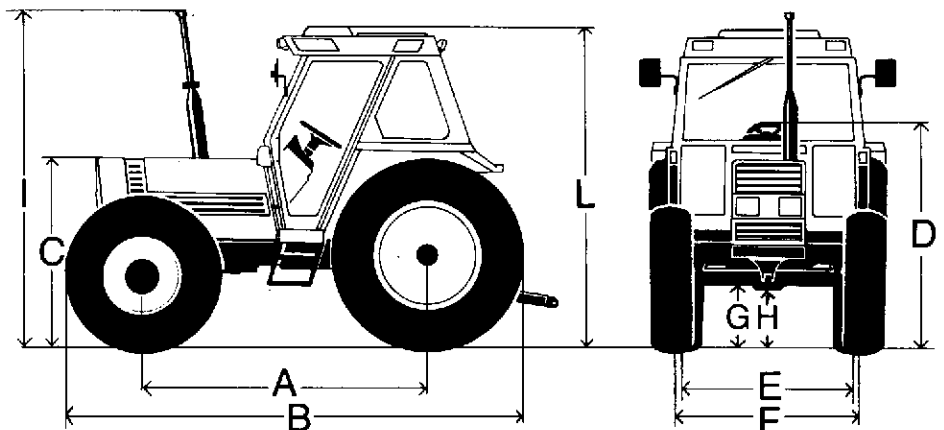

FIAT
Trattori

The information contained in this leaflet is intended to be of a general nature only.

The Fiat Trattori Company may at any time and from time to time, for technical or other necessary reasons, modify any of the details or specifications of the product described in this leaflet.

To be sure of getting accurate, detailed and up-to-date information, an intending buyer should consult his nearest Fiat Trattori dealer or distributor or branch.

Fiat Trattori Pubblicità - Publication No. 603.26.181
Printed in Italy - Stamperia Bancheo - Milan - 5/84.