



MODEL 1255
125 DIN HP





MODEL

1255
1255XL De Luxe Cab

ENGINE

Type	Four stroke direct injection, turbocharged, water cooled diesel
Power - S.A.E. DIN NET	125hp, 92kW at 2200 rev/min
Max. Torque	488 Nm at 1700 rev/min
Torque at Rated Speed	400 Nm
Fuel at max. power	236g/kWh
Bore x Stroke	98.4 x 128.5mm
No. of cylinders	6
Capacity	5867cc
Compression Ratio	16:1
Governed Range	760 - 2410 rev/min

CLUTCH

Type	Double dry plate for transmission and PTO
Diameter	355mm

TRANSMISSION

Type	12 forward, 5 reverse, synchromesh
------	------------------------------------

Ground Speed on Standard Tyres (2WD)

Min. speed at 540 rev/min PTO	Low	High	Reverse	km/h
1	2	1	1	2.5
2	3	2	2	2.6
3	4	3	3	4.1
4	5	4	4	6.4
5	6	5	5	9.8
6	1	6	6	15.0
1	2	1	1	19.0
2	3	2	2	3.2
3	4	3	3	5.0
4	5	4	4	7.8
5	6	5	5	11.8
1	1	1	1	18.4
2	2	2	2	23.1
3	3	3	3	3.7
4	4	4	4	5.9
5	5	5	5	9.2
6	6	6	6	13.9
1	1	1	1	21.6

Four wheel drive
Option on-the-go engagement through multi-plate clutch.
Planetary reduction in hubs
Limited slip differential

POWER TAKE OFF

Type	Two Speed Independent
Max. Power	121.3hp, 89.2kW
Power at 540 rev/min PTO	121.1hp
Power at 1000 rev/min PTO	121.1hp
No. of splines	21
Engine revs at 540 rev/min PTO	2118
Engine revs at 1000 rev/min PTO	2136
Clutch type	Independent

HYDRAULIC SYSTEM

Max. Pressure	2488lb/in ² 175kg/cm ²
Flow	11 gal/min 50 lit/min
Power	18.7hp, 13.8kW
Linkage Lift, links horizontal	10588lb, 4801kg
Optional Assister Sensing	12713lb, 5767kg
Linkage Category	Lower Link 2/3

DRAWBAR

Type	Swinging drawbar with clevis
Max. Pull - 4WD	19465lb, 8829kg
Max. Power - 4WD	106hp, 78.5 kW

BRAKES

Foot	Hydraulic Drum Self adjusting
Diameter	10.6in, 27cm
Hand	Mechanical band brake

STEERING

Type	Hydrostatic
Turning radius	
- with brakes	164in, 418cm
- without brakes	183in, 465cm
- 4WD with brakes	193in, 490cm
- 4WD without brakes	224in, 570cm

ELECTRICAL

Battery	12v 143Ah
Alternator	55 Amp

CAPACITIES

Fuel Tank	30.8 gal, 140 lit
- XL Cab	44.0 gal, 200 lit
Cooling System	6.9 gal, 31.4 lit
Engine Sump	2.7 gal, 12.5 lit
Transmission Case	
- 2WD	7.5 gal, 34 lit
- 4WD	8.8 gal, 40 lit

DIMENSIONS

A. Wheelbase - 2WD	110 in, 280 cm
- 4WD	110 in, 280 cm
Width, min. track	93 in, 237 cm
B. Height Non Cab	
Steering wheel	86.6 in, 220 cm
C. XL Cab	113 in, 287 cm
Front track - 2WD	60-72 in, 152-183 cm
- 4WD	73-81 in, 186-206 cm
Rear track	72-84 in, 184-214 cm
D. Ground clearance	
Drawbar	15.4 in, 39 cm

WEIGHTS – BASIC TRACTOR

XL Cab 2WD Front	3968 lb, 1800 kg
Rear	7187 lb, 3260 kg
Total	11155 lb, 5060 kg
With 4WD add	1366 lb, 620 kg

WHEELS & TYRES, STANDARD

2WD Front	W5.50F-20 with 7.50-20 6 ply F2
Rear	W15L-38 with 18.4 R38 8 ply R1
4WD Front	W12-28 with 13.6 R28 6 ply R1
Rear	W15L-38 with 18.4 R38 8 ply R1

STANDARD EQUIPMENT

Accelerator

Hand and foot throttles

Air Intake

Dry type with safety element and service indicator
Turbocharger

Alternator

55 Amp

Anti-freeze solution

Axle

Front, straight, adjustable

Battery

12 volt, standard duty

Clutch

Hydraulic drum

Clutch

Double dry plate for transmission and PTO

Differential Lock

Foot operated, synchronised

Drawbar

Swinging type with clevis

Engine

6 cylinder direct injection, turbocharged

Fuel Tank

Under floor

Hitch

3 point category 2/3 with telescopic stabilisers

Hydraulics

Independent, exact hydraulics with draft and position control

Hydraulic Valve

One double acting with break-away coupling

Instrumentation

Tachometer, fuel and water temperature gauges, warning lights for engine oil pressure, battery discharge, headlamp beam

Lighting

2 head, side and tail

Muffler

Vertical with rain cap

Power Take Off

Single shaft, two speed independent

Seat

Deluxe with fore-aft and height adjustment

Steering

Hydrostatic power

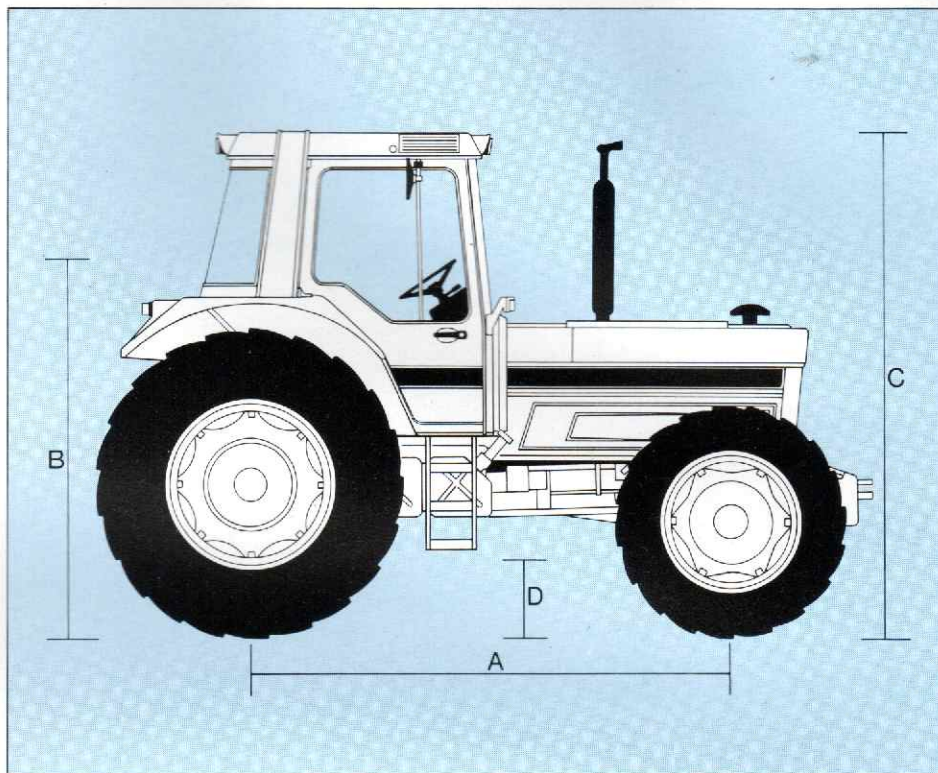

Transmission

12 forward, 5 reverse, synchromesh
Range – high, low and reverse, synchromesh
Speed – 6 speed, synchromesh

Weights

Inner bolster weight with integral draw clevis

OPTIONAL EQUIPMENT

Assister Ram

70mm diameter in lieu of 50mm diameter

Battery

Light duty

Brakes

Disc brake for fwd axle
Hydraulic trailer brakes
Pneumatic trailer brakes

Cab

Safety frame with roof
XL Cab, luxury flat deck control centre with roof hatch, sound absorbing upholstery, deluxe heater demister, sun visor, tool box with passenger seat, deluxe suspension seat with cloth upholstery, seat height, weight, fore and aft adjustment with arm rests.
Air conditioning

Drawbar

Short

Fenders

Front, Rear, crown type. Rubber extensions.

Fuel Tank

Additional tank, non XL 13.2 gal, 60 lit

Hitches

Trailer hitch, height adjustable

Hydraulic valves

Non Cab – Double or single acting, up to 3 may be fitted
XL Cab – Double/single acting, up to 3 may be fitted

Lighting

Non Cab – Direction indicators, warning lights
Working lights
XL Cab – Working lights, 2 front
Working lights, 1 rear

Seat

Super deluxe, cloth covered
Super comfort with side tilt, cloth covered
XL Cab – As standard with reclining back rest, head rest, lumbar support
As above with air suspension, swivel and automatic weight adjustment

Transmission

Case IH Hydropower Turbo Clutch
20 forward, 9 reverse synchromesh with creep speed
Four wheel drive, side drive with on-the-go engagement, planetary hub reduction and limited slip differential

Weights

Suitcase weights
Centre part of three suitcase weights with draw clevis
Rear wheel weights

Wheels and Tyres

Refer to price list



This literature has been published for worldwide circulation. As availability of equipment builds vary according to the country in which the equipment is to be used, the illustrations and text may include optional equipment and accessories and may not include all standard equipment. Your Case International Distributor/Dealer will be able to give you details of the products and their specifications available in your area.

The company's policy is one of continuous improvement and development. Therefore specifications are subject to change without notice. Whilst every effort is made to uphold accuracy within literature, the company accepts no responsibility for discrepancies which may occur between the specifications of its machines and the descriptions thereof contained in its publications.



Published by:
J I Case Europe
Case House, PO Box 89
85/89 High Street, Walton-on-Thames
Surrey KT12 1DL, England

J I Case
A Tenneco Company

