

MF 8200



**Massive power and high
performance from 145 to
260 DIN PS**



MASSEY FERGUSON





Controlled power with massive strength and performance

Just glance at the 8200 Series from Massey Ferguson and you immediately get a feel for its elegant strength and 'presence'. Look more closely and you'll see that every major component has been massively engineered to give you the performance and reliability you demand.

All new 'green' engines

The latest Perkins or SISU DIESEL 'green' engines are used throughout the 8200 Series. All are turbocharged, most have intercoolers and all feature 'Dynatorque' characteristics to ensure that power and torque are matched perfectly to the job in hand.

Unique transmissions

The latest-generation 18 speed Powershift gearbox features smooth operation combined with tremendous strength and durability. It also features 'Power Control' which, uniquely, provides left hand command of power shuttle, Powershift changes and de-clutching, in addition to the armrest mounted Powershift control.



Silver medal for Trailed Implement Control system

The latest heavy duty version of the acclaimed Dynashift gearbox is also available, providing a really cost-effective 32 forward 32 reverse speed transmission with no less than 15 speeds in the field working range.

Simple, comfortable operation

The handsome cab is well equipped and offers excellent space and visibility. The instruments and controls combine with the most comprehensive range of electronic driving aids, including **Dual Control** and unique, award-winning **Trailed Implement Control** (Silver medal winner, Agritechnica 99), to simplify operation, improve work quality and increase output.

Powerful engineering

From the heavy duty front axle to the massive all-new 'modular' rear axle, the entire 'transaxle' is designed to withstand the rigours of the toughest work schedules. **That's why with the MF 8200 Series, peace of mind comes as standard!**



MF 8210 (145 DIN PS)



MF 8280 (260 DIN PS)

Model	Engine	Capacity	DIN PS
MF 8210	6 cyl. turbo	6.0 litre	145
MF 8220	6 cyl. turbo	6.0 litre	155
MF 8240	6 cyl. turbo	6.6 litre	170
MF 8250	6 cyl. turbo	7.4 litre	185
MF 8260	6 cyl. turbo	7.4 litre	210
MF 8270	6 cyl. turbo	8.4 litre	230
MF 8280	6 cyl. turbo	8.4 litre	260



MF 8220 (155 DIN PS)



MF 8260 (210 DIN PS)



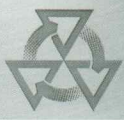

MF 8200 Series ... the highlights in brief

- With high power and torque, the advanced 'green' engines are fully emissions compliant, so they are also kinder to the environment. (Pages 10-11)
- Massive new transmission and rear axle components mean added strength and durability in tough conditions. (Page 18)
- Unique **Trailed Implement Control** (optional), silver medal winner at Agritechnica 99, ensures maximum productivity and ease of operation with trailed implements. (Page 23)
- The smooth, latest generation 'Powershift Plus' transmission, available on all models, has 18 forward and 8 reverse speeds, with 10 speeds within the field working range. (Pages 12-14)
- Powershift Plus features '**Power Control**'. This unique left hand lever gives simple command of power shuttle, powershift changes and 'clutch' control. (Page 12)
- Alternatively, the 32 speed Dynashift transmission provides 4 powershift changes in eight synchronised gears, and 15 speeds within the field working range. (Pages 14-15)
- The 'flat floor' cab provides excellent visibility and well placed instruments and controls. The pneumatic seat, air conditioning and stereo also help to maintain peak efficiency. (Pages 6-9)
- 'Closed centre' load sensing hydraulics give instant response at all times. Low power and cooling requirements mean low power losses, for better fuel economy. (Pages 18-19)
- The highly responsive ELC system features simple controls, with the most frequently used switches conveniently mounted in the seat armrest. Improved linkage geometry gives very high lift capacity on all models. (Pages 20-21)
- Dual Control (optional) provides unbeatable productivity from semi-mounted equipment. (Page 22)
- The 'Transmission Controller' automatically monitors, controls and protects transmission related functions. It also automatically handles many otherwise manual repetitive tasks. (Described throughout the brochure)
- Datatronic II* provides accurate information, plus 'wheelslip control' and 'comparative mode'. There is simply no better information, control and cost management system available today. (Page 22)
- The MF 8200 Series is also fully compatible with Massey Ferguson's FIELDSTAR™ precision farming system; a uniquely valuable aid to your profitable development into the next millennium.

*Optional on MF 8210-8250 Powershift models, standard on all others







More space and superb controls, for simpler operation

The stylish cab provides excellent visibility and plenty of space. The precise, well-placed controls and clear instrumentation enable maximum operating efficiency.

Unhindered access

Access to the spacious cab is really easy from either side of the tractor. With two wide-opening, rear-hinged doors, large self-cleaning steps and a flat, uncluttered floor area. Inside, the seat is fully adjustable, including lumbar support. There's also a swivel facility to give the operator a more comfortable view of rear mounted equipment. Neatly folded away to the left of the main seat, a secondary seat is available which can be quickly raised into position to give a passenger a safe, comfortable ride.

Excellent visibility

5.7m² surface area of tinted glass, narrow pillars and side-mounted

exhaust all help to ensure excellent all-round visibility. New, large, telescopic rear view mirrors with a handy rotary knob for simple adjustment, are a further aid to safe manoeuvring and transport.

Outstanding comfort

Air filtration, tinted glass all round, efficient heating and ventilation - including rear 3/4 and rear window demisting, plus air conditioning as standard all enhance comfort and driver efficiency. And when work schedules get really tight, the excellent internal and external lighting, convenient storage areas, drinks cooler, high quality stereo and exceptionally quiet cab, all help to boost output and performance by keeping the driver fresh and alert.

Below: Spend the longest working days in cool, relaxed comfort

Right: Cab gives superb space, comfort and control (Powershift model shown)



Right: Visibility in all directions is excellent, with slim cab pillars



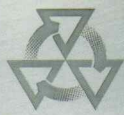

Maximum productivity through ergonomic efficiency

Simplicity is the key to control in the 8200 Series. Clear instruments, large switches and rotary controls, uniquely efficient gear and clutch control; all clearly identified and close at hand, for safe, easy operation.

Unique Power Control

On Powershift models the well placed Powershift lever and unique **'Power Control'** take all the effort out of gear selection. Power shuttle, powershift changes and de-clutching are all finger-tip controlled by a single left hand lever. So the right hand is free to operate linkage and hydraulic controls, for faster headland turns and reduced cycle times.



Smooth, simple controls

The steering column is adjustable for angle and reach, so you can get just the right driving position. In addition to simple transmission control, there is a large rotary PTO switch, well positioned, ergonomically designed auxiliary hydraulic levers and simplified electronic linkage control console.

Overhead console

Overhead, the roof hatch can be opened for additional 'natural'

ventilation. In the neat roof console, a large analogue clock, stereo and air conditioning controls are conveniently located alongside a handy drinks holder/chiller.

Digital instrumentation

The 'automotive' style dashboard features both conventional analogue and digital read-outs, so different types of information are displayed in the optimum way for fast, easy assimilation of vital data.



Speed selection is either via the Power Control lever or the armrest control (Powershift models)

Left: Power Control means total control; total simplicity

DCC display

The Display Cab Controller (DCC), is standard on Powershift models. Pre-programmed gear selection, travel direction and current gear engaged are clearly displayed on an LCD read-out which also provides diagnostic

codes. A 'Field Facts Monitor' is also incorporated, which monitors and displays a range of vital data.

Simple, precise controls

With a simplified ELC panel, the most frequently used controls mounted in the right armrest, and

spool valve, PTO and gear levers all close at hand, MF 8200 Series ergonomics are superb.

Automated control

One other significant factor contributes to the ease of operation ... automated control. With the standard **Transmission Control** system 'managing' a number of transmission related functions and **Datatronic II** (optional on some models, described more fully on page 22) providing highly accurate information, plus automatic wheelslip control, efficient operation and high quality work go hand in hand with comfort and safety.

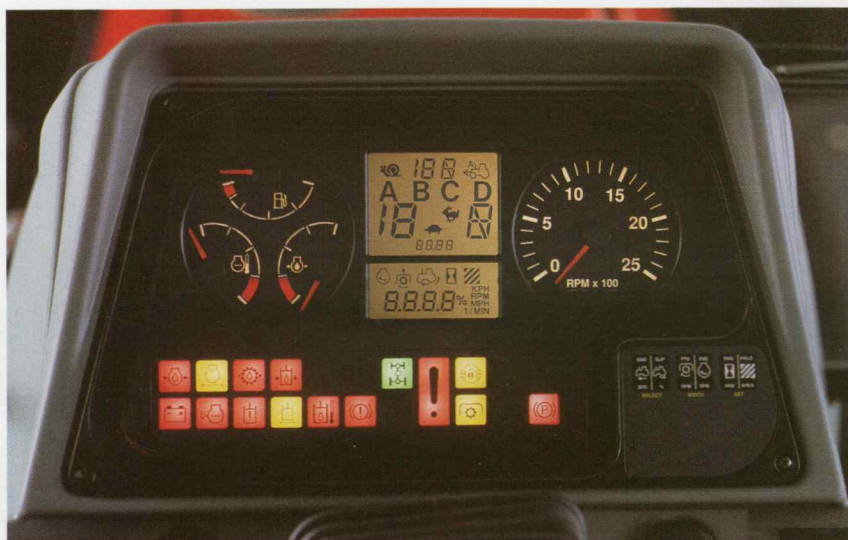

Clear display of all vital data (Powershift, DCC console shown)



Layout includes armrest mounted controls (Dynashift model shown)



Powerful engines; efficient transmissions, for 'real' usable power

8200 series tractors are equipped with advanced, 6-cylinder turbocharged engines which provide exceptional power and torque. And, more importantly, this power is put to work through the latest generation Powershift or Dynashift transmissions and the advanced electronic and hydraulic systems, so up to around 95% of the engine power is available at the wheels and PTO for operating equipment more efficiently.

'Fastram' (MF 8210/8220)

Fastram combustion creates air 'swirl' within the cylinder head, so air enters the combustion chamber in the piston crown at very high speed. The result is precisely controlled, highly efficient combustion, lower noise levels and lower fuel consumption.

Dynatorque engines

After extensive research of the power and torque requirements of different types of work, Massey Ferguson has developed its range of Dynatorque engines to give precisely the right combination of power and torque for each job and engine speed.

For example, **zone A** (see diagram), between 1800 and 2200

rev/min, covers heavy duty PTO applications. The need here is for high torque and rapid torque rise, to ensure that PTO speed is maintained at all times.

The engines have also been designed to give maximum power at PTO rated speed. This can be as much as 4.5% greater than rated power, ensuring optimum performance with high



Right: Fastram combustion system on the advanced MF 8210/20 engines

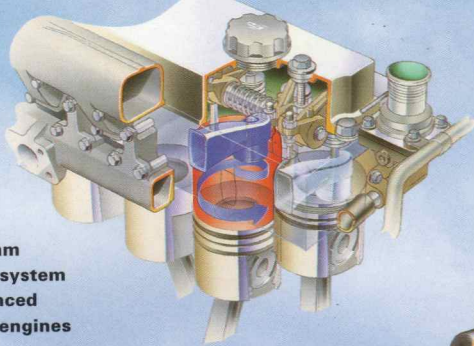

power PTO equipment. Power is maintained at, or above rated power in this zone, giving a massive 400 revs of 'power-plus performance'. In non-PTO applications, you can reduce engine speed whilst maintaining performance and greatly enhancing fuel efficiency.

Zone B, from 1400 to 1800 rev/min, covers general heavy duty farming applications, economy PTO work and transport. Here, the need is for high overall torque, as operating speed is often less important than just 'lugging' ability. Progressive torque rise perfectly complements the MF change-on-the-move transmissions

for superb in-field performance. The 'bulged' power curve also means that in economy PTO applications, 85% of rated engine power is still available, giving high performance, reduced in-cab noise and exceptional fuel efficiency. Transport applications are also perfectly catered for by having massive torque at low engine speeds, ensuring easy starting with the heaviest trailers.

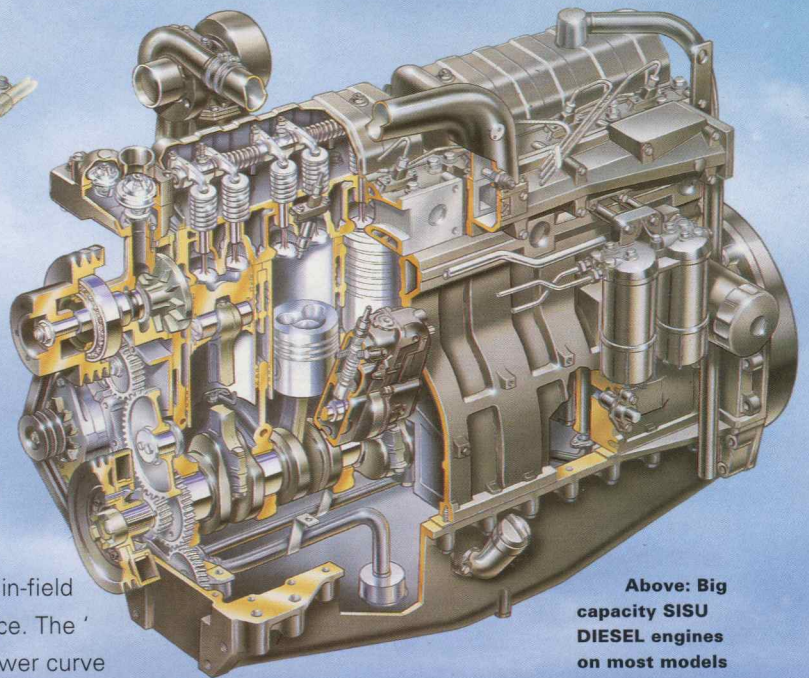

Above: Big capacity SISU DIESEL engines on most models

Below: The curve shows the ideal power and torque characteristics of MF's Dynatorque engines

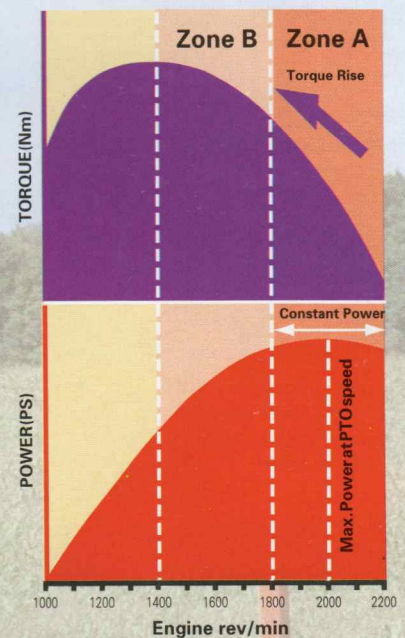

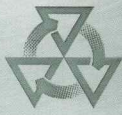

New-generation Powershift: smooth, strong, with unique Power Control

The new-generation 18 speed Powershift gearbox provides excellent ground speed coverage with smooth, simple operation, plus tremendous strength and durability.

Smooth Powershift transmission

The 18 forward, 8 reverse speed (17 forward speeds when limited to 30

km/h) Powershift transmission is electronically controlled for almost imperceptible gear changes and enabling all changes to be made on-the-move under load, without declutching.

Left or right-hand control

In addition to total control from the armrest mounted Powershift lever,

'Power Control' uniquely, provides left hand command of both forward/reverse power shuttle, Powershift changes and 'declutching' which, though not required for gear changing, is still useful for momentarily disengaging drive when manoeuvring in tight spaces.

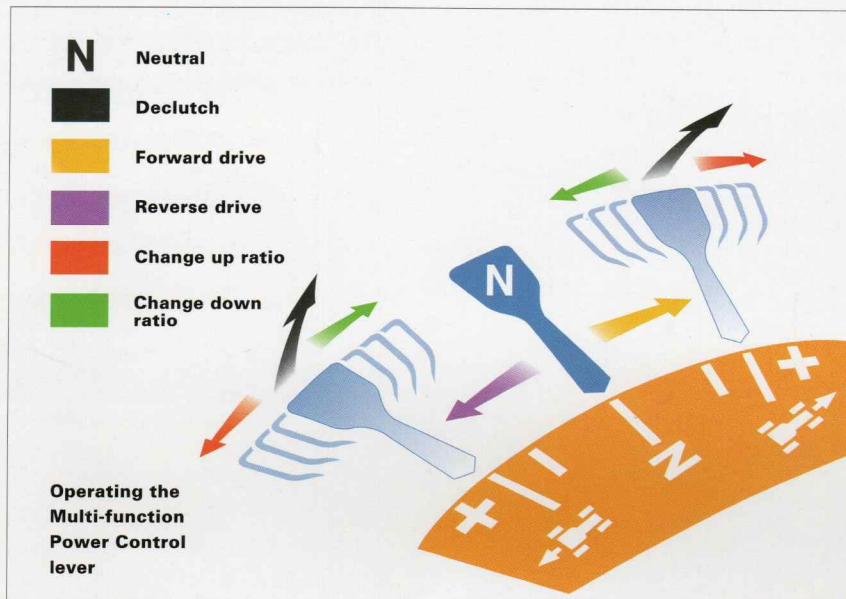

Below: New-generation Powershift transmission has 10 speeds within the 4-12 km/h field working range

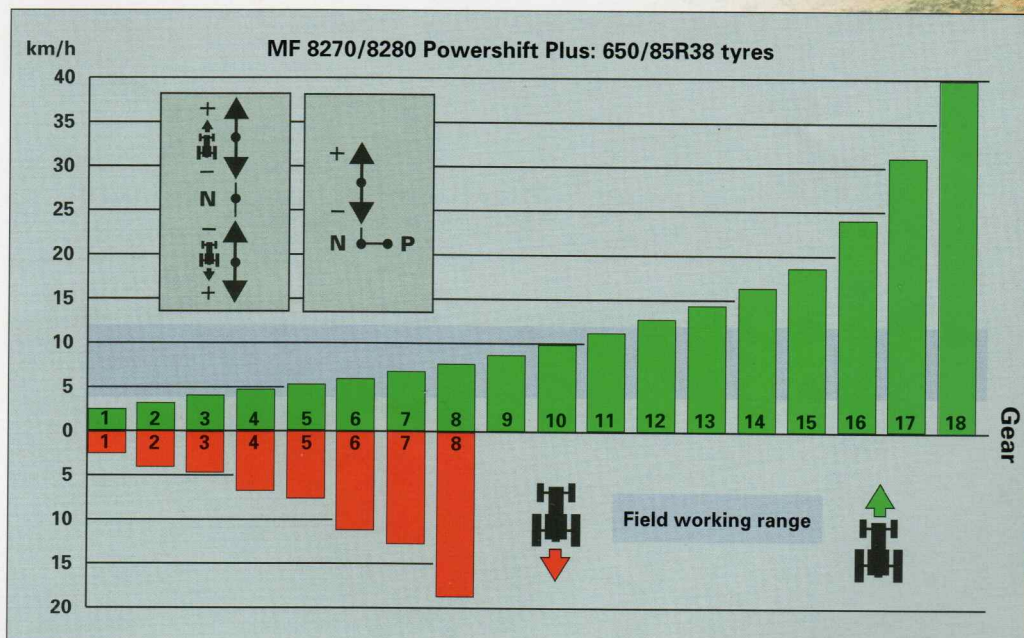

Wide range of field and transport speeds

Simplicity of gear selection, is further enhanced by a 13% speed difference between 3rd and 15th gears and a 29% difference between the other ratios, so you can accurately and instantly match ground speed to virtually any application.

Choice of shift options

The electronic control system also enables a choice of shift options. These include the ability to preselect travel speed and forward/reverse shuttle speed; automatic speed matching while in transport, whereby

when slowing down for a junction or hazard, depressing the clutch will automatically select the best gear for the reduced road speed; 'sequential shifting', and single gear changes – all from either the armrest-mounted lever or Power Control.

Creep speed options

Creep speeds are available as an option, giving speeds as low as 600 metres per hour for specialist applications.





New generation Powershift: Massive construction and strength

Depending on tractor power, two versions of the Powershift gearbox are produced. Similar in design, both are massively constructed (the larger version is over 900 kg in weight) and easily capable of withstanding the heaviest workloads.

Modulated clutches

This 'latest-generation' Powershift transmission features exceptionally smooth ratio changes. This is achieved using nine electronically controlled, modulated clutches; three of which are engaged at any time to achieve drive. The fast, smooth changes mean that no momentum is

lost in the field as with slower ratio changes. So less power and fuel is absorbed in regaining forward speed.

The design also gives lower power losses than conventional Powershift transmissions as all gears, bearings and clutches have positive pressure lubrication from the transmission's own dedicated pump. This means that the oil level in the gearbox can be lower than conventional designs, so there is less 'drag' on gears and shafts.

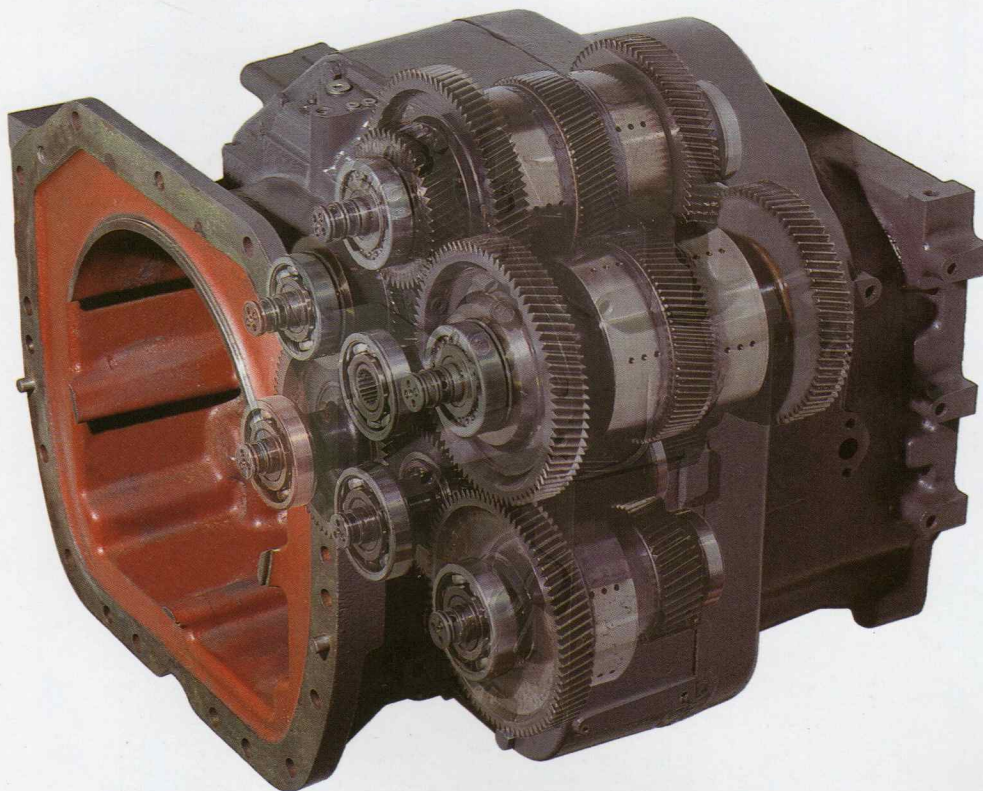

Latest generation Powershift gearbox is massively constructed, rugged and smooth

Dynashift transmission

Cost-effective, yet providing highly efficient utilisation of power, the acclaimed Dynashift transmission gives outstanding flexibility, driving ease and output.

Oil-cooled clutch

Drive is transmitted through a multi-plate clutch which has a very large surface. It is cooled and lubricated by up to 32 litre/min of oil provided by its own independent pump.

Powershift ranges in eight gears

Dynashift provides a smooth, silent 4 speed powershift change in each of the eight synchronised gears. So you can always choose a gear with all the powershift flexibility you need to cope with varying conditions. And as Dynashift has 'close ratio' steps of only 17%, you can maintain optimum efficiency at all times. Of the 32 forward speeds, 15 are in the field working range, so whatever the job, the correct speed is always available to optimise performance.

Finger-tip Dynashift control

The position of the Dynashift lever enables the operator to steer and change speed with the left hand, leaving the right hand free to operate other controls. This encourages full use of Dynashift at all times, plus simultaneous command of all other control systems, giving greater efficiency and superior work quality.

Matched forward/reverse speeds

Forward/reverse selection is by a simple, mechanical, left-hand lever.

Dynashift: simple, cost-effective, providing outstanding driving flexibility

Reverse speeds are precisely matched to the forward speed in use, giving effortless headland turns and faster cycle times.

Rapid transport

To move from the field to the maximum road speed, simply change through the synchromesh gears into 'top', then flick the Dynashift lever from 'A' to 'D' ratio in a single movement. Dynashift will change up automatically, but only when the next ratio can be accepted without a significant drop in engine speed and consequent pulling power.

Simple design

Dynashift is based on a simple design concept, and is executed with remarkable mechanical efficiency. It is essentially a four speed epicyclic unit controlled by two electrovalves. In addition to the obvious benefit of 'built-in' durability, power losses through such a simple unit are minimal.

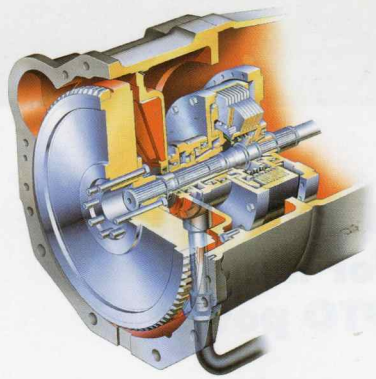

Oil-immersed clutch (7-plate version shown, for Dynashift MF 8240 models)

Safe operation

The Dynashift transmission has fully synchronised range and gear changes for smooth, reliable operation. It is also fully protected against inadvertent selection of the wrong range because Transmission

Control prevents changing from one range to another if the speed of the tractor is too great for the gears to be properly engaged.

Rugged construction

For added durability and quiet operation, the Dynashift gearbox incorporates very wide, helical gears. The design gives added strength to cater for the massive torque loads being transmitted.

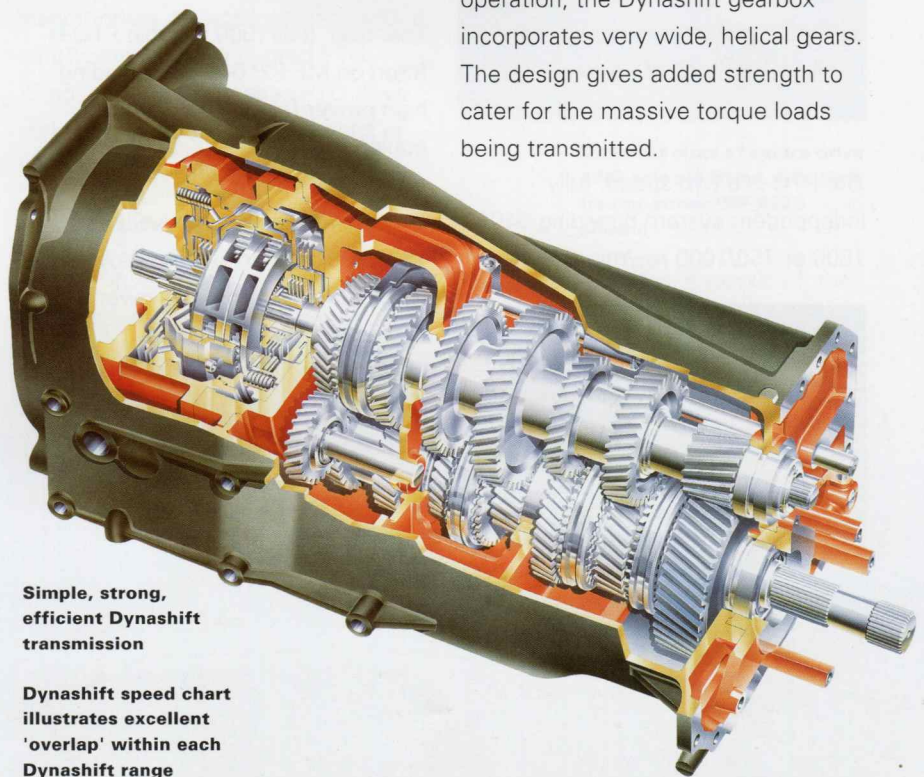

Simple, strong, efficient Dynashift transmission

Dynashift speed chart illustrates excellent 'overlap' within each Dynashift range



Simple gear pattern aids gear selection

Dynashift lever and manual shuttle

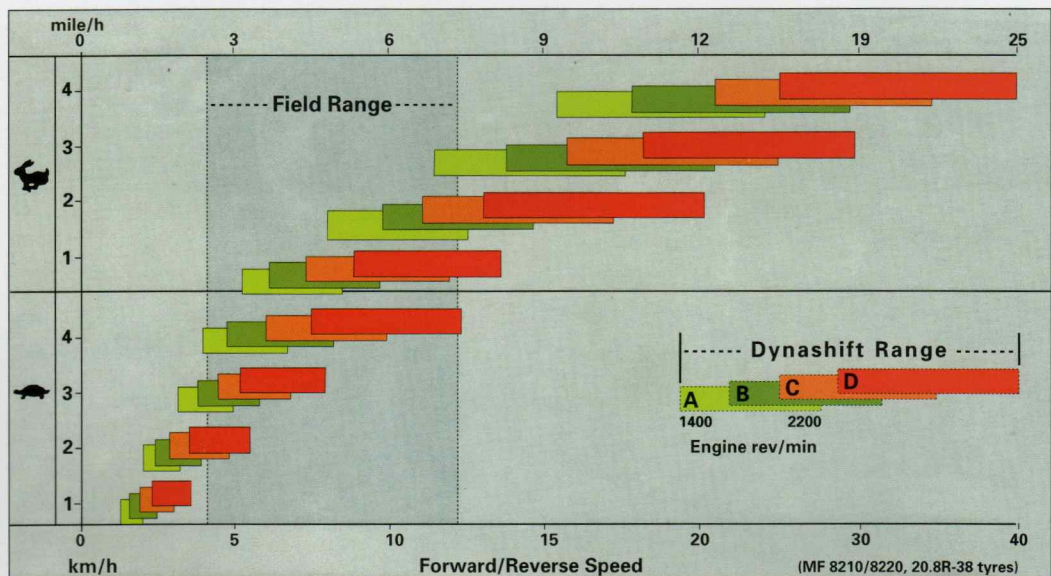

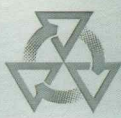

Simple design for maximum PTO power

The 8200 Series provides more usable power at the PTO. The simple design means that the PTO is driven directly from the engine flywheel, so it is very strong, with very low power absorption, giving maximum power at the PTO shaft. Standard PTO speed is achieved at 90% of rated engine speed, so there is also lots of power in reserve.

The PTO is a two-speed, fully independent system providing 540/1000 or 750/1000 rev/min speeds.



The bolted, flanged shaft design means that any PTO shaft can be used at any speed and shaft exchange is easy and leak-free. PTO speed is 'shiftable', either by an in-cab or external lever, depending on model.

The 'true' 540/1000 rev/min PTO is fitted on MF 8210-8250, providing high power for all PTO driven equipment.

On larger models, from MF 8260, the 750/1000 rev/min system provides 540 PTO speed at much lower engine speed, so light duty implements, which do not require full power, can be driven with reduced fuel consumption and noise. PTO

Left: Rear (and optional front) PTO actuated by large rotary switches. (Optional) In-cab shiftable PTO lever also shown

speed is 'shiftable', either by an in-cab or external lever, depending on model.

The MF 8270-8280 can deliver massive power through their high capacity 44 mm drive shafts. PTO performance can be monitored through both the 'Field Facts Monitor' or Datatronic II, giving the operator all the information needed to optimise the performance of these range-topping models.

Fender mounted PTO 'Stop' control for added safety



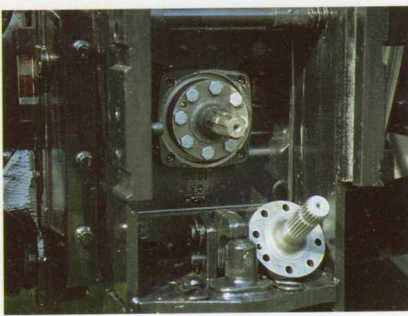

The 'flanged' design gives a fast, leak-free PTO shaft change

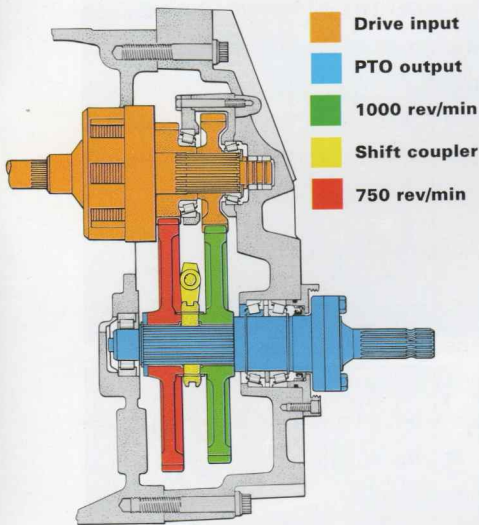

Independent, shiftable PTO system offers 540 Economy, (750) and 1000 rev/min speeds

Automated control

The Transmission Control system also monitors and manages PTO clutch engagement depending on load. This gives greater operating safety and protects both implement and tractor from damage due to inappropriate engagement. For added safety, the fender-mounted PTO 'Stop' control disengages PTO drive instantly, for specific applications or in emergency situations.

4-wheel drive axle

The MF 4-wheel drive axles are designed to withstand frequent use of heavy front-mounted equipment. The centre mounted drive shaft gives excellent ground clearance and, with no universal joints, power losses are minimised.



Different sizes of centre drive 4WD axle are fitted, to match tractor power (MF 8220 shown)

To ease the operator's workload, the Transmission Controller automatically activates differential locks and 4-wheel drive at appropriate times.





Massive construction for strength, High capacity for output

Massive new rear axle

The massive 'modular' rear axle is completely new and is, quite simply, the biggest in the industry. It houses large oil-cooled disc brakes and heavy duty epicyclics, with twin discs and, uniquely, twin epicyclic units on larger models.

Power brakes

Power brakes are standard on all models. By assisting pedal pressure, greater braking force is achieved with a minimum of effort. The brakes provide exceptional stopping power and great durability.

At the touch of a button, simultaneous actuation of the

differential locks ensures maximum traction at all times. The differential lock ensures fast, 100% engagement and disengagement of the differential, with no slippage or loss of power.

Getting more power to the ground

Setting a new standard in the 230-260 hp range, the huge 650/85R38 tyres, fitted to MF 8270/80, were specially developed by Massey Ferguson and Kleber They can withstand higher loads with lower pressures, minimising soil damage and compaction whilst transmitting more power - with less slip and less tyre wear.

To meet the oil flow and pressure demands of large equipment or multiple front/rear combinations, the 8200 Series features a 'closed centre, load sensing' hydraulic system as standard.

Automatic regulation

Sensing lines throughout the system ensure that flow and pressure are automatically regulated according to demand, so there's no wasted power - or fuel - used in pumping oil that's not required.

The totally new rear axle (MF 8270/80 shown) features large oil immersed disc brakes and heavy duty inboard dual epicyclic reduction units ensuring strength, safety and durability.

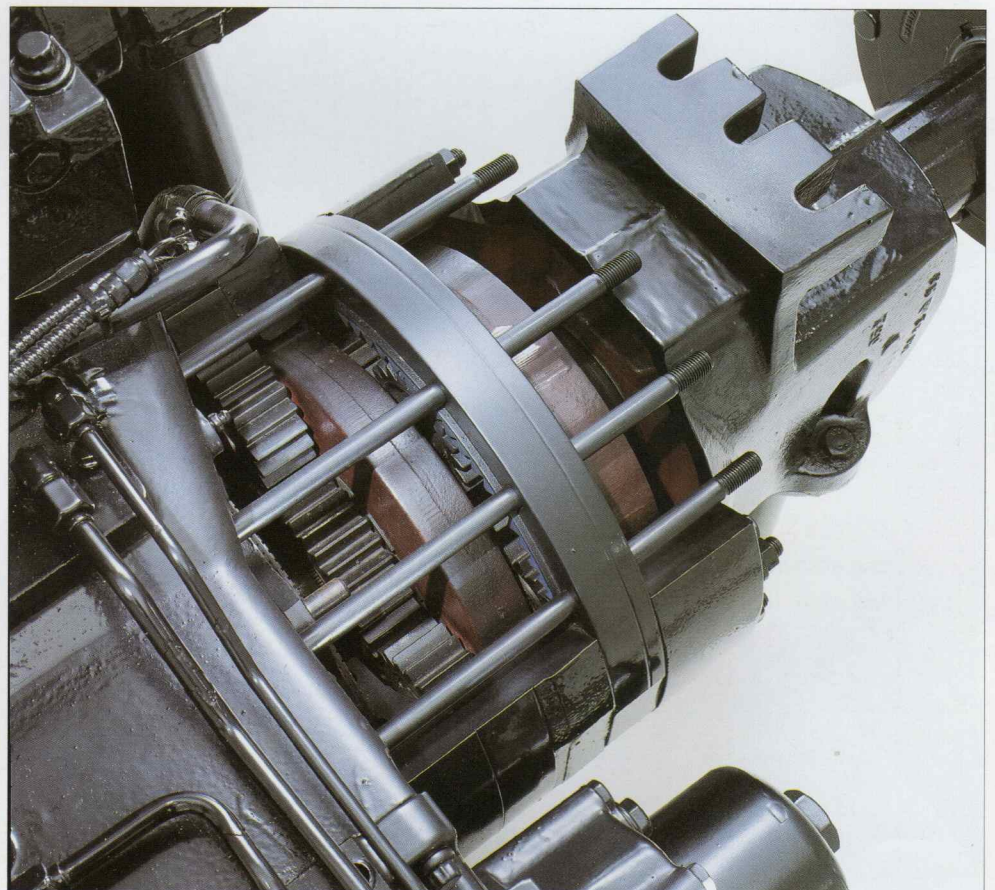



Each spool valve has individual flow control from the driver's seat

Axial piston pump enables rapid response to flow demands

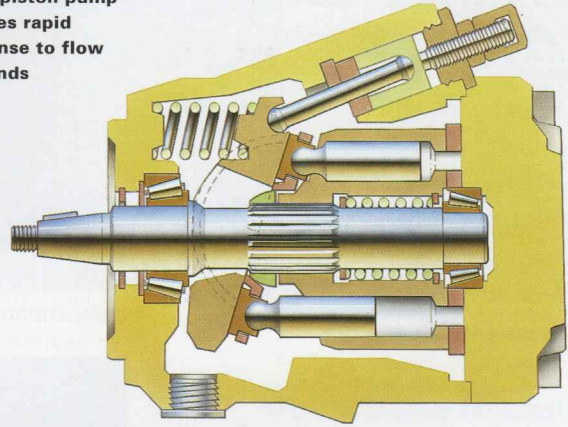

Lever-action couplers mean easy connection and disconnection, even when pressurised

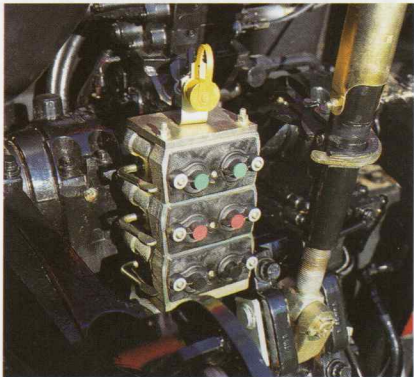

Instant response

But when there is a need for oil flow, it's there on demand – instantly. With 110 litres per minute (or 150, as an option on Powershift models) at a pressure of 200 bar being available in less than 1/20th of a second. That's what you call fast response.

Precise auxiliary flow control

Up to four spool valves can be fitted on 8200 Series tractors, each with individual flow control adjustment. This enables the valves to deliver very precise amounts of oil right up to their maximum flow, giving more accurate implement control for better work quality and greater safety.

Linkage is built for up to 10 tonne lift capacity (MF 8260-8280). German specification MF 8270 linkage with T.I.C. shown.





MF electronic linkage control ... for accuracy, response and simplicity

For many years, Massey Ferguson's electronically controlled linkage has been the industry leader in terms of design simplicity, responsiveness, accuracy, ease of use and reliability. With simplified controls and improved ergonomics, the 8200 Series is even more satisfying to operate.

The latest generation, digital electronic linkage control system (or ELC), uses electronic sensors to measure draft forces through the lower links, with an additional sensor on the lift arm cross shaft to register linkage lift height. The sensors send signals to a microprocessor – the system's brain – which compares these signals with others from the driver when he adjusts the settings on the ELC console.

More accurate draft control

The digital ELC system gives a higher standard of draft control for more accurate depth settings and better ground contour following. The result is more weight transfer and better traction, giving less wheel slip, reduced tyre wear and fuel consumption and greater output.



Simple ELC panel

With the more frequently used controls armrest mounted and a simplified ELC control panel, accurate operation is easy. And in addition to all the normal linkage control functions, the system also incorporates advanced integrated features. Intermix, maximum lift height, quick soil engagement and automatic drop speed are all standard.

For faster implement attachment the rear linkage can also be operated from conveniently mounted push buttons on each rear fender.

Standard Active Transport Control

When driving across the headland or transporting heavy mounted equipment, implement 'bounce' can occur.

Left: Excellent ergonomics are a feature of the integrated Electronic Linkage Control system.

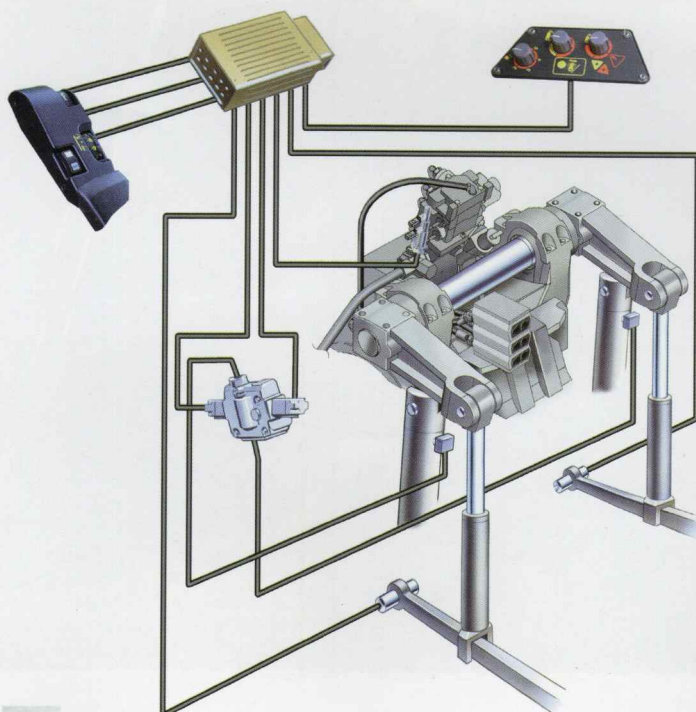

Above: ELC gives almost instantaneous response to draft signals, for precise ground contour following.

Active Transport Control (ATC) is integrated into the ELC system as standard. It is a shock absorbing system which minimises the 'pitching' action – automatically adjusting for different implement weights. This gives smoother, safer, faster transport and also, by reducing the shock loads through the lift rams and hydraulic circuits, also minimises the risk of damage to the lift system.

ATC is independent of the transport lock and can be controlled either manually at the touch of a button, or



automatically, whereby it is linked to the lift/lower switch of the ELC panel. It is then activated when the implement is raised and deactivated when the implement is lowered.

Above: Integrated Active Transport Control gives faster, safer transport of mounted equipment.

Below: Whatever the task, you can rely on MF 8200 linkage and hydraulics





Advanced systems to increase productivity and reduce costs

Datatronic II

Datatronic II, gives an added dimension to the fundamental high performance of the MF 8200 Series. To high power and transmission efficiency, it adds information and control.

Datatronic II has over 20 functions, including cost-analysis and Comparative Mode displays, 4 programmable memories and hard copy print-out capability.

As well as assisting the driver, the information gathered by Datatronic is an invaluable farm management tool, which takes the guesswork out of calculating fertiliser application rates, seeding rates, acreage worked



An infra red link gives print-out capability



and much more. And with four programmable memories, which can be identified as either a different implement, a different driver or, for contractors, work undertaken for different customers, the data is really comprehensive.

Wheelslip control

In draft work, Datatronic processes data from radar and ELC through the numeric CAN BUS system. This provides a unique wheelslip control feature which increases traction and therefore the tractor's performance with draft controlled implements. Wheelslip control maintains high quality work, whilst increasing output, reducing tyre wear and protecting soil structure.

Dual Control

When using semi-mounted ploughs, Dual Control automates furrow entry and exit, even in irregularly shaped fields. It also aids setting the plough and evenness and control of work. It is controlled and monitored via the standard ELC panel plus two extra functions within Datatronic II. Dual Control automatically moves the plough's furrow/depth wheel in relation to the lower links, so Draft Control keeps the plough parallel to the ground instead of raising only the front furrows. With Dual Control you get simple operation, plus the full benefit of wheelslip control when operating semi-mounted ploughs.

Datatronic II, with over 20 functions and twin digital displays

Trailed Implement Control (T.I.C.)

T.I.C. builds still further on Massey Ferguson's lead in field efficiency. MF introduced the first and (still) the most accurate Electronic Linkage Control system; then the first fully automatic wheelslip control system; then Datatronic and onto the 'gold medal' winning Dual Control system. Now Trailed Implement Control, winner of the Silver medal at Agritechnica 99, is another 'first'. It is a unique system for optimising productivity when using trailed equipment.

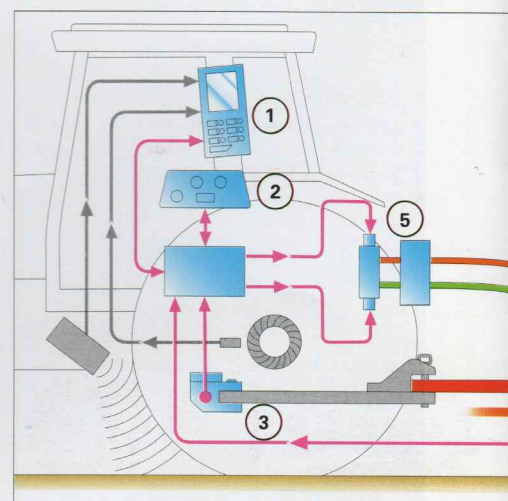



Trailed Implement Control - Silver medal winner at Agritechnica 99



Dual Control significantly increases output with semi-mounted equipment

T.I.C. uses draft force and wheelslip data and an implement mounted height sensor, to automatically regulate working depth through an electronically controlled spool valve. Like Dual Control, it is operated via the standard armrest-mounted ELC controls and monitored via extra functions within Datatronic II.

Output is further increased by wheelslip control, unique to MF, with trailed equipment. The combined result is less operator effort, reduced fuel consumption and increased workrate.



FIELDSTAR™

FIELDSTAR™ is Massey Ferguson's precision farming system, designed to help maximise crop gross margins and overall profit.

The system is intelligent and will automatically recognise which implement is connected to the tractor. Therefore only relevant information to that implement can be accessed, making it very easy for the operator.

Fieldstar is not only a complete tractor and combine harvester monitor and control system, it is also designed as a comprehensive implement control system connected quickly and simply via a single socket.

The System is designed to perform the functions of, and thus replace,

any implement control units. It will work using GPS, with or without a Fieldstar controlled implement.

Inputs can be automatically varied according to pre determined application maps created on the farm computer. With an implement supplied control box, the implement can be manually adjusted according to the tractor position shown on the terminal.

Precision farming investments are reduced as you do not need an implement box, you simply use the Fieldstar terminal.

The system is easy to keep up-to-date with the latest developments as it is programmable. This also enables new implements to be added enabling the Fieldstar terminal to control them.

Left: Unique T.I.C. can increase output with trailed equipment by up to 15%, or more in some conditions

T.I.C. system components

1. Datatronic II
2. ELC controls and processor
3. Drawbar draft force sensor
4. Implement height sensor
5. Electro-spool

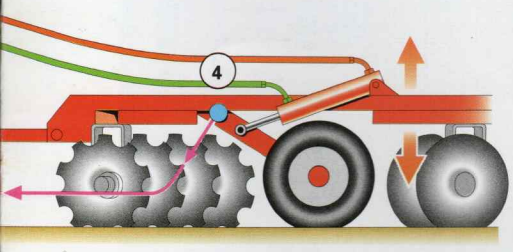

The FIELDSTAR™ monitor (optional) fits neatly next to the main console

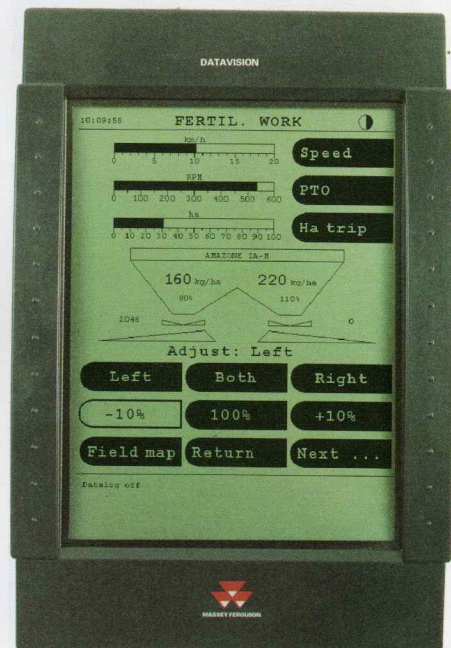



Tailor your tractor to meet your needs

A wide choice of options is available, which enable you to vary the specification of the tractor to meet your specific requirements.

Front linkage and PTO

Front linkage and PTO were designed into the 8200 Series from the outset, for maximum productivity and quicker return on capital investment. Using front/rear implement combinations can give real time savings - up to 30% when drilling, with consequent savings in fuel, manpower utilisation and reduced soil compaction.



Hitches

8200 series tractors can be specified with a hitch to suit any application or need. The swinging roller drawbar is ideal for heavy duty trailed implements; high visibility automatic hitches, to ease trailer attachment; height-adjustable trailer hitches for use with heavy twin-axle trailers, and many more, ensure ease of operation and maximum output in any application.

Added weights and ballast

Quick-attach front weights and belly weights are available. Matching tractor weight or weight distribution depending on the demands of a particular application helps to increase traction and output.

Work lights

Additional front, rear and footstep-mounted work lights can be specified to improve night working productivity. The spring loaded rotating beacon hinges down to enable access to low buildings etc.

Below: Additional weight can be added to the tractor in a variety of ways for added ballast



Above: Additional front, rear and footstep mounted work lights are available

Front linkage and PTO for high productivity, single pass operations (front PTO not available On MF 8270/80)

Right and below right:
A wide range of
wheels and tyres are
available, including
cast centre for added
weight and welded rim
for extra strength in
haulage applications



Passenger seat

The passenger seat enables a second occupant to travel in safety and comfort.

'Panorama' roof

The Panorama roof provides greatly improved upward visibility from the normal seating position. The roof opens to two positions, the second of which enables it to slide rearwards for added ventilation or, in the event of an emergency, escape.

Carbon cab air filter (Parts accessory, not illustrated)

The normal paper element filter can be replaced by a carbon filter, to provide extra protection when spraying toxic chemicals.



Above: Left side passenger seat



Right: Wider fender extensions are available to suit larger tyre sizes



Below: Linkage and hydraulic specifications are available to suit all market needs and legislation. (MF 8220, UK specification shown, below)

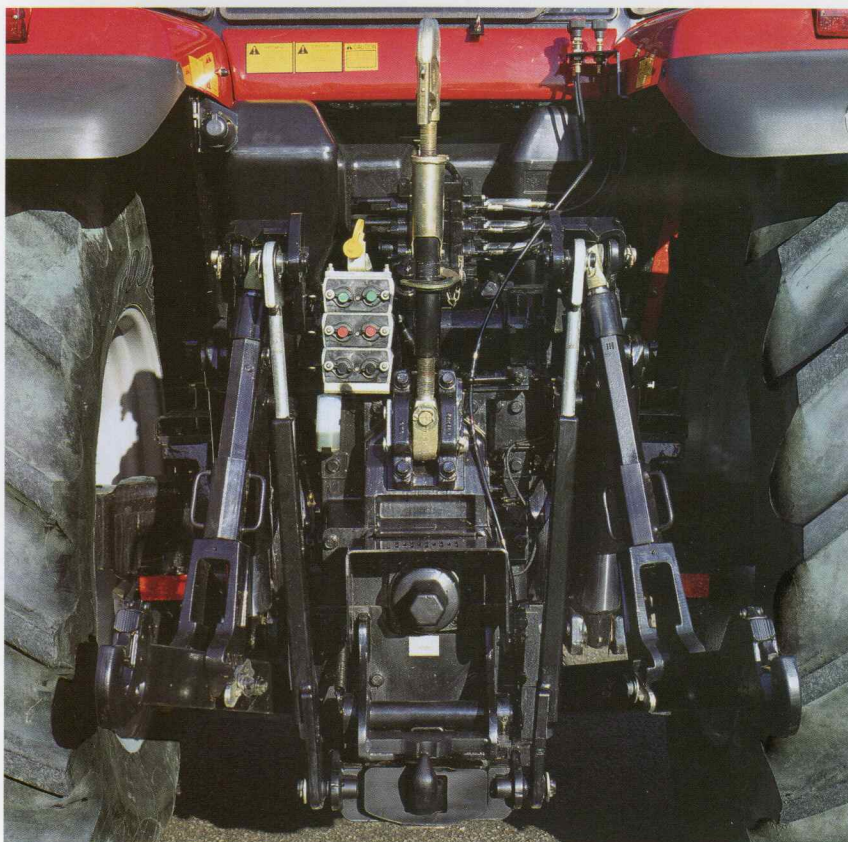

Below: The Panorama roof provides enhanced upward visibility

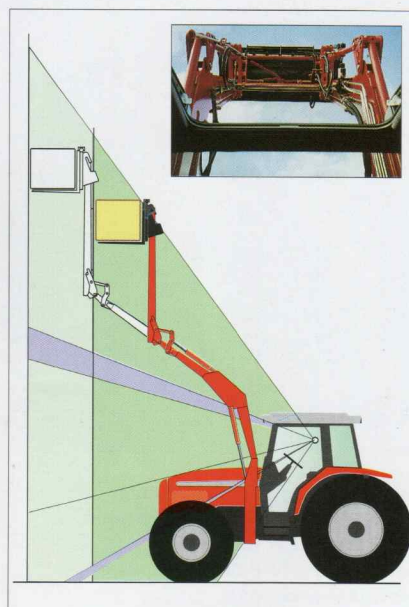



Simple servicing and routine maintenance

Less wear, resulting from automatic control of tractor functions means fewer adjustments – simplified servicing. And when the tractor needs attention, it's easy as engine side panels and grille are simply removed or hinged so that all components are readily to hand.

Simplified servicing is a theme that runs right through the 8200 design. On Dynashift models, the multi-plate oil-cooled clutch dissipates heat quickly and efficiently using its own independent oil supply from an integrated pump. Clutch life is very long and no adjustments are required. The brakes too are self-adjusting, the battery is low-maintenance and there are no more than ten grease points - all readily accessible.

There is only a single dipstick check

for engine oil level, with a sight glass on the rear axle for an easy visual check of transmission oil level. Time between services is longer than ever, with transmission oil and filters only needing to be changed every 1000 hours and engine service intervals extended to 300 hours.

The hydraulic system, filters and valves are all external and the pump is located on a side cover allowing easy access and reduced maintenance time. There's no need for cab removal, as side covers on the transmission housing provide ready access to gear selectors and clutches, should the need arise.

Fuel filling is easy too, with the 'A-post' mounted fuel filler.

It all adds up to greatly simplified daily and service routines, to reduce downtime, and boost work output.



Above and right: Radiator slides clear of engine compartment for easy access for thorough cleaning. Battery and air cleaner access is good too.



Right and below:
Large removable
panels or the hinged,
tilting bonnet give
unhindered access
to engine, battery,
cooling systems, and
cab filters and air
conditioning.





MF 8200 series tractors

Key: N/A = Not available/applicable ● = Standard equipment ○ = Optional equipment

		8210	8220	8240	8250	8260	8270	8280										
Performance																		
Engine power																		
@ 2200 rev/min	**PS (kW)	145 (107)	155 (114)	170 (125)	185 (136)	210 (154)	230 (169)	260 (191)										
Max. torque	** Nm	593	643	727	797	878	984	1137										
@ rev/min		1400	1400	1400	1400	1400	1400	1400										
** = DIN 70020																		
Engine																		
Water cooled, direct injection diesel		●	●	●	●	●	●	●										
Model		1006.60TWG	1006.60TWG	620DSE	634DWE	634DSBIE	645DSBIE	645DSBIE										
Aspiration		Turbo/wastegate	Turbo wastegate/intercooler	Turbo/intercooler	Turbo/intercooler	Turbo/intercooler	Turbo/intercooler	Turbo/intercooler										
No. cylinders		6	6	6	6	6	6	6										
Bore/stroke	mm	100/127	100/127	108/120	108/134	108/134	111/145	111/145										
Capacity	litre	6	6	6.6	7.4	7.4	8.4	8.4										
Air cleaner, dual dry, with exhaust aspiration		●	●	●	●	●	●	●										
Side mounted exhaust		●	●	●	●	●	●	●										
Clutch (Dynashift models only)																		
Multi-plate, oil cooled with integral gear pump		●	●	●	●	N/A	N/A	N/A										
Transmission																		
32 forward, 32 reverse speed synchro gearbox, with manual synchro shuttle and 4-speed powershift		●	●	●	●	N/A	N/A	N/A										
Creeper option giving an additional 16 F/R 'creeper' speeds. 4:1 reduction, giving speeds from 600 m/h		○	○	○	○	N/A	N/A	N/A										
18 forward, 8 reverse powershift with electronic control of pre-selectable starting, forward/reverse shuttle and auto speed matching. Left hand 'Power Control' of shuttle and powershift changes Creeper option giving an additional 18 F / 8 R 'creeper' speeds. 4:1 reduction, giving speeds from 600 m/h		○	○	○	○	●	●	●										
Road speeds. Note: Reverse speeds are matched to related forward speed. Speeds in km/h.																		
Dynashift		8210/8220				8240/8250												
		20.8R-38				20.8R-42												
1 A-B-C-D		2,6-3,1-3,5-4,2				2,6-2,9-3,5-4,2												
2 A-B-C-D		3,9-4,5-5,3-6,3				3,9-4,5-5,3-6,1												
3 A-B-C-D		5,6-6,4-7,7-9,0				5,5-6,4-7,6-8,8												
4 A-B-C-D		7,6-8,8-10,5-12,2				7,4-8,7-10,3-12,1												
1 A-B-C-D		8,4-9,8-11,6-13,7				8,4-9,6-11,4-13,3												
2 A-B-C-D		12,9-15,0-17,8-20,7				12,5-14,8-17,4-20,4												
3 A-B-C-D		18,3-21,4-25,3-29,6				18,0-21,1-24,9-29,1												
4 A-B-C-D		24,9-29,0-34,4-40,2 [†]				24,5-28,6-33,8-40,0 [†]												
Powershift																		
	1	2	3	4	5	6	7	8	9	10	11	12	13	14	15	16	17	18[†]
20.8R38 tyres (8210/20) [†]	2,2	2,9	3,8	4,3	5,0	5,6	6,2	7,2	8,2	9,3	10,6	12,0	13,6	15,4	17,4	22,6	29,2	37,6
20.8R42 tyres (8240/50) [†]	2,2	2,9	3,9	4,3	5,0	5,6	6,3	7,2	8,2	9,3	10,6	12,1	13,7	15,4	17,5	22,7	29,3	39,0
620/70R42 tyres (8260) [†]	2,2	2,9	3,9	4,3	5,0	5,6	6,3	7,2	8,2	9,3	10,6	12,1	13,7	15,4	17,5	22,7	29,3	39,0
650/85R38 tyres (8270/80) [†]	2,4	3,1	4,0	4,5	5,1	6,0	6,6	7,6	8,7	9,8	11,1	12,7	14,3	16,3	18,5	23,8	30,7	39,3

[†]Top gear is locked out for markets restricted to 30 km/h max speed.



	8210	8220	8240	8250	8260	8270	8280
Power take-off, rear							
Independent, operated by switch, actuated by hydraulic clutch, with electronic control	●	●	●	●	●	●	●
Shaft change; Shifttable/flanged	●	●	●	●	●	●	●
PTO speed @ engine rev/min							
540 rev/min	2090	2090	2090	2090	1440	1440	1440
1000 rev/min	2090	2090	2090	2090	2090	2090	2090
Shaft diameter							
35 mm (1 3/8 in), 6 or 21 splines	●	●	●	●	●	●	●
44 mm (1 3/4 in), 20 splines	N/A	N/A	N/A	N/A	○	○	○
Front power take-off and linkage							
Front linkage	○	○	○	○	○	○	○
PTO, independent, operated by switch actuated by hydraulic clutch	○	○	○	○	○	N/A	N/A
Shaft diameter mm	35	35	35	35	35	N/A	N/A
PTO speed @ engine rev/min							
1000 rev/min (6 or 21 spline shaft)	2040	2040	2040	2040	2040	N/A	N/A
Front linkage lift capacity kg	3500	3500	3500	3500/5000	3500/5000	3500/5000	3500/5000
Rear linkage							
Electronic control of draft, position Intermix, height/depth, rate of drop, 'quick soil engagement' and Active Transport Control	●	●	●	●	●	●	●
Dual Control	○	○	○	○	○	○	○
Trailed Implement Control	○	○	○	○	○	○	○
Lower links, Cat. 3 hook end	●	●	●	●	●	●	●
Max lift capacity at link ends, links horizontal kg	8700	8700	8700	8700	10000	10000	10000
Hydraulics							
Closed centre load sensing system	●	●	●	●	●	●	●
Pump Output litre/min	110	110	110	110	110	110	110
Optional on Powershift models	150	150	150	150	150	150	150
Max. pressure bar	200	200	200	200	200	200	200
Auxiliary hydraulics - control							
Three spool valves each with individual flow control	●	●	●	●	●	N/A	N/A
4th spool valve	○	○	○	○	○	●	●
Steering							
Hydrostatic	●	●	●	●	●	●	●
Tilt/telescopic steering column	●	●	●	●	●	●	●
4WD front axle							
Max. steering angle degrees	55	55	55	55	55	50	50
Differential lock	●	●	●	●	●	●	●
Brakes							
Oil-cooled, with hydraulic actuation	●	●	●	●	●	●	●
Number of plates per side	1	1	1	1	2	2	2
Parking brake, independent, multi-plate disc on transmission, hand lever operated	●	●	●	●	●	●	●
Trailer brakes; hydraulic, pedal operated	●	●	●	●	●	●	●

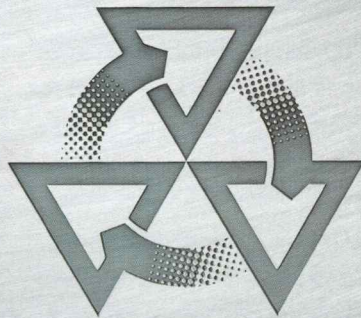
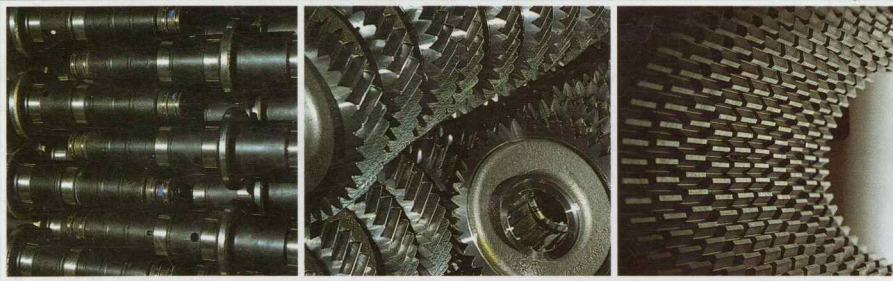

THREE POINT POWER

Powerful engineering. Powerful products. Powerful support

Point one reflects our heritage of innovation and engineering excellence.

Point two recognises the demand for superior products with more controllable power.

Point three is our solid commitment to support your tractor throughout its lifetime, with personalised finance arrangements, professional service and guaranteed, readily available parts, all delivered by our world-renowned Dealer network.

Three Point Power - making these tractors as revolutionary as our original three point linkage.



Specifications are subject to change without notice and may vary from country to country. Please check with your distributor or dealer at the time of placing your order.

Massey Ferguson is a world wide brand of AGCO Corporation.

Website:
www.masseyferguson.com