



**MF INDUSTRIAL
& CONSTRUCTION
MACHINERY**

MF 2244 CRAWLER DOZER



Big tractor performance in a compact usable size

- 44 HP Diesel - has ample reserve engine torque for lugging power required in a crawler
- Long five roller track frame with large diameter front idler offers excellent balance and flotation
- Fast - easy hydraulic track tension adjustment lets you adjust track tension in seconds
- Well engineered operator's compartment provides excellent visibility and convenient hydraulic controls for fast exact control of dozer and ripper

MF 2244 CRAWLER DOZER ENGINEERING SPECIFICATIONS

DOZER

Blade: Width 80", height 24". Hydraulic lift, tilt 5½° and angling 25°.

Hydraulic Controls: One four way, one two way lever located at fingertips of operator right hand.

Hydraulic System: Gear type pump 17 GPM @ 2000 RPM w/2150 PSI. Replaceable 10 micron filter.

RIPPER

Controls: Hydraulic double acting cylinder controlled by lever conveniently located with dozer controls at operator's right hand.

Penetration: Parallel linkage allows constant penetration at any depth from 0 - 8".

Number of Teeth: Three

Lift Clearance: 12"

Width: 58"

Weight: (approximately) 1,260 lbs.

DRIVE TRAIN

Transmission: Four speed Manual Shuttle (travel speeds forward 0 - 6.12 MPH, *reverse 0 - 7.10 MPH.

*Reverse speeds 16% faster than forward.

Steering: Multiple disk clutch and hand brake.

Master Clutch: single dry disk, 11" diameter.

ENGINE:

Diesel: Low rpm, high torque 3 cylinder 152.7 cubic inch, 44 hp (with all standard accessories) @ 2250 rpm. Develops 119 ft. lbs. torque @ 1300 rpm.

Under Carriage: 48" gauge track with five rollers and one carrier. Available with 12" full grouser shoes. Rigid suspension, hydraulic track tension adjustment.

Total Weight: Crawler Dozer & Ripper approx. 8,965 lbs.

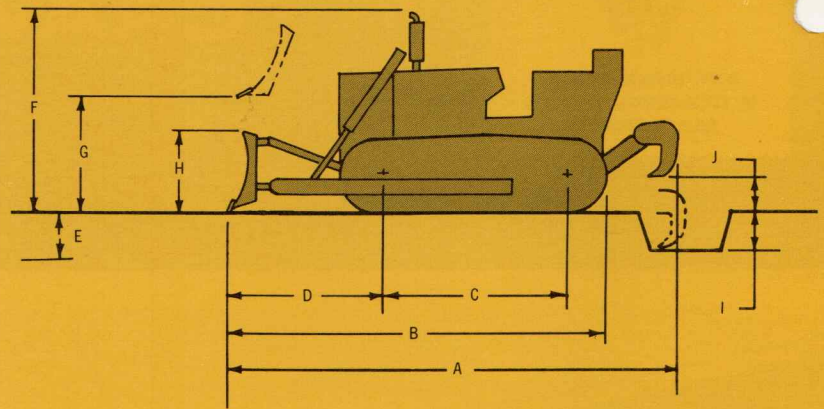

A	B	C	D	E	F	G	H	I	J
163½"	137"	62¼"	61"	10"	81"	38"	24"	8"	12"

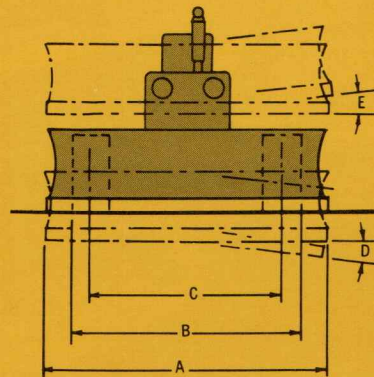

A	B	C	D	E
80"	60½"	48½"	5½°	5½°

Massey-Ferguson reserves the right to make changes in design or to add improvements to its products without incurring any obligation on goods purchased prior to such changes or improvements.



**MF INDUSTRIAL
& CONSTRUCTION
MACHINERY**

Massey-Ferguson Inc.
Akron, Ohio