

MF

**Massey Ferguson
MF 255/265/275 TRACTORS**

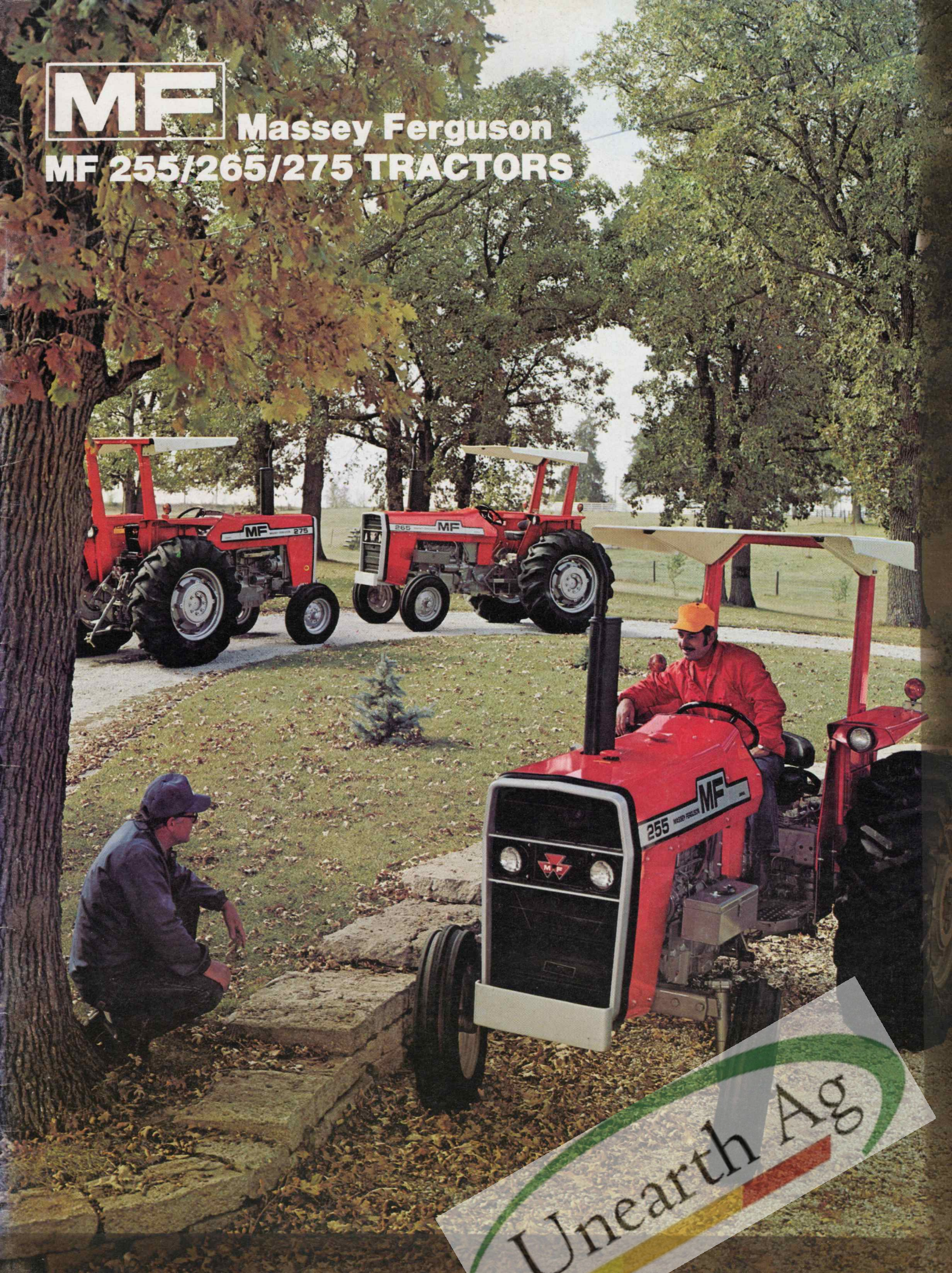

Unearth Ag

Ravn 165
\$10-

52* to



67 hp strong

3 outstanding full-farm tractors

Put together a checklist of tractor features. Things like wider power choice. All-new looks. Convenience features. Servicing ease. Better range of speeds. Improved hydraulics. Many more most-wanted features.

You can find some of these things on most any make tractor. But only Massey-Ferguson puts all this and more together in feature-packed MF 255, MF 265, and MF 275 tractors. Now more than ever, Massey-Ferguson is your top choice in the 52* to 67 hp class.

Each of these three MF tractors is available as a standard clearance, row crop, or low profile model. They handle nearly any job on any crop or livestock farm.

Plenty of options are available, but you get many important standard features with a MF 255, MF 265, or MF 275, too. Plus one more feature you can't find anywhere else. That's the MF world-wide reputation for economical, long-life performance and better value for your tractor dollar. Look them over. Then put MF power to work for you. Soon.

* Mfg. est.



Unearth Ag

MF 255

52 hp* – Eager to tackle many tough jobs

There's an unbeatable combination of power, economy, and proven reliability in a MF 255.

Choose a standard clearance MF 255 for enough muscle to handle tillage, loading, hauling, mowing, or 101 other jobs on grain and livestock farms. You get much of the same versatility with an MF 255 row crop, plus extra clearance for cultivating. Or choose a low profile MF 255 for orchard, grove, or specialty crop work.

Any MF 255 offers a rugged 236 cu. in. Perkins diesel with economy that's been the envy of the industry for years.

Backing up that power is an 8-speed manual transmission with convenient speed choices, or 12-speed shift-on-the-go Multi-Power. And you get MF modern hydrostatic power steering as standard equipment. Choose live or independent PTO. There's extra comfort with spring-suspension seating. Easier servicing with good-looking hood and grille that come off in a minute. And true big-tractor hydraulic capacity with optional auxiliary hydraulics.

The MF 255 is a tractor that has performance to match its sharp looks. Find out what it can do for you!

* Mfg. est.





Standard Clearance (with 16.9-24 tires)

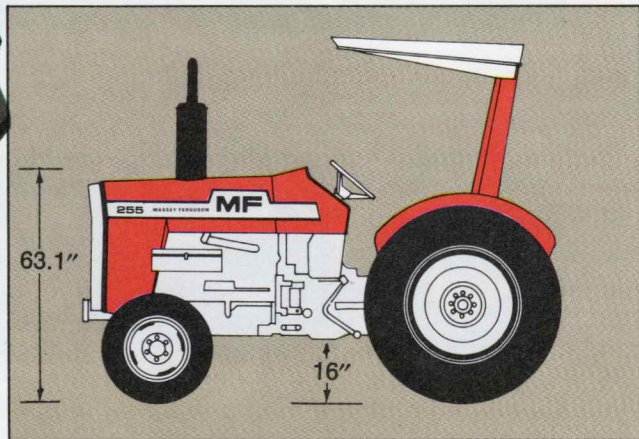

Row Crop (with 14.9-38 tires)

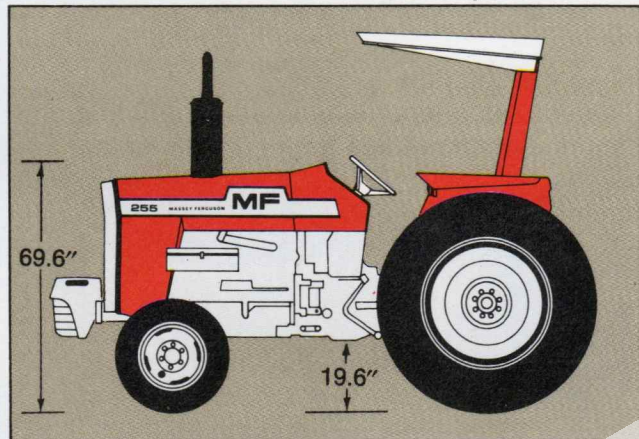

Low Profile (with 18.4-16.1 tires)

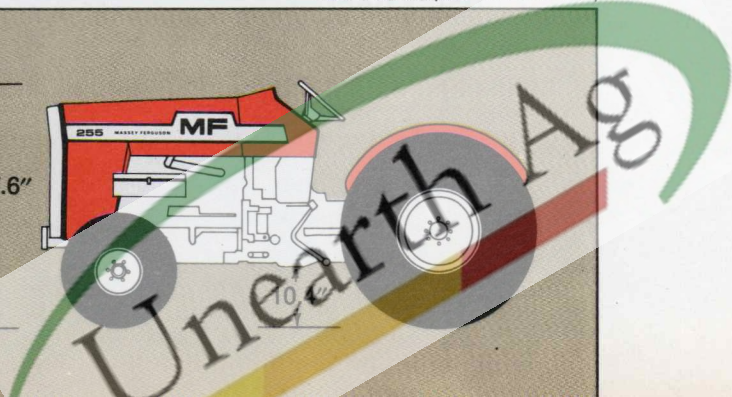
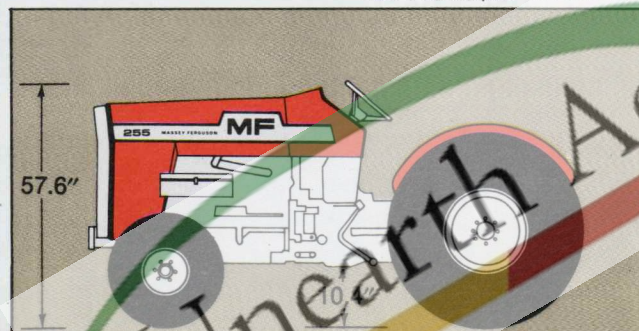

New front battery location makes servicing easy. Battery runs cooler, so it lasts longer and needs less servicing.

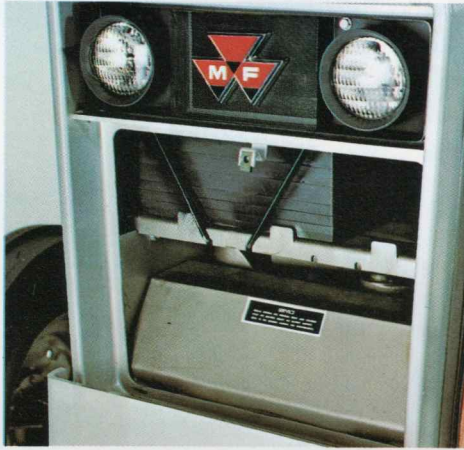

Indicator shows at a glance if the dry air filter element needs service. No need to remove it until the indicator shows red.



servic



Fuel and coolant filler caps are outside the hood. No hinged panels to open every day.

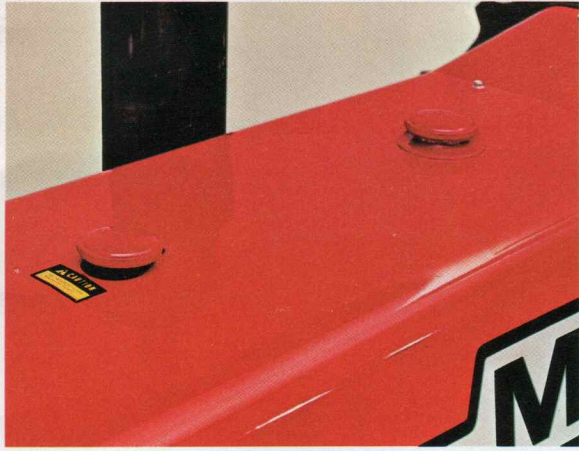

Grille screens, side panels, and one-piece hood all come off. There's clear access to filter, battery, and entire engine.

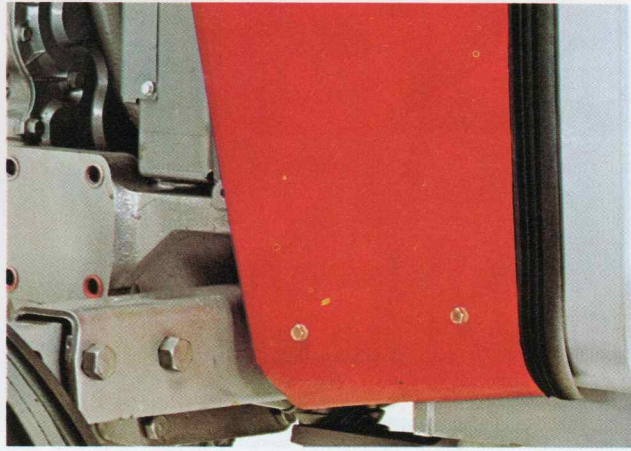

ng ease

Gets you from farmstead to field faster

At today's fast-moving farming pace, no one has time to "baby" machinery. A tractor should be designed so it spends more time working—and you spend less time servicing. That's exactly how Massey-Ferguson designed the MF 255, MF 265, and MF 275.

Example: Gone are the days when servicing the air cleaner was a time-consuming job. Now an air cleaner restriction indicator lets you see at a glance if the filter element needs attention.

Hydraulic system on these tractors is far easier to service, too. An access port now makes servicing the standard pump strainer easy. With optional auxiliary hydraulics, there's a replaceable filter mounted near the rear axle, where it's easy to reach. Lower front grille comes off in seconds for easy access to battery, oil cooler, and oil lines. Upper grille screen comes off just as easily for servicing the big dual-element dry air cleaner. MF gives you modern, up-to-the-minute design.

New front battery location means the battery stays cool. You won't have to add water so often. Fuel and radiator filler caps are out in the open. No need to unlatch access doors, or lift the hood, to fill up.

With Massey-Ferguson, daily servicing is so simple you won't want to overlook it. And major maintenance, when needed, is also easier. The payoff: You'll be a more satisfied tractor owner when you choose MF.

Unearth Ag



Standard Clearance (with 16.9-24 tires)

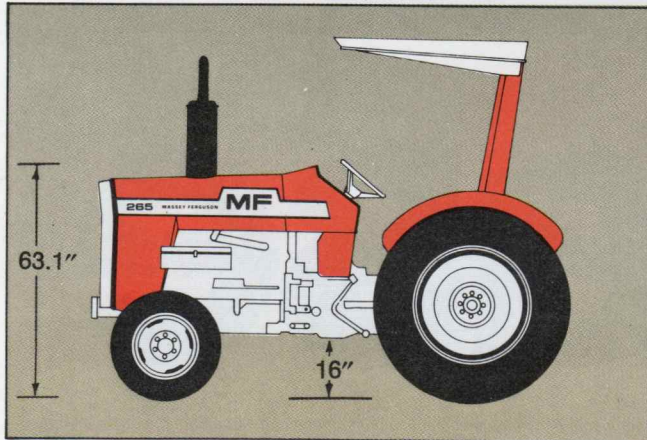

Row Crop (with 15.5-38 tires)

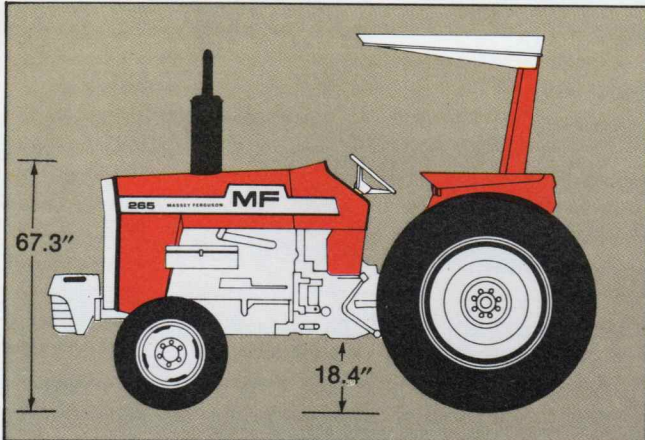

Low Profile (with 16.9-24 tires)

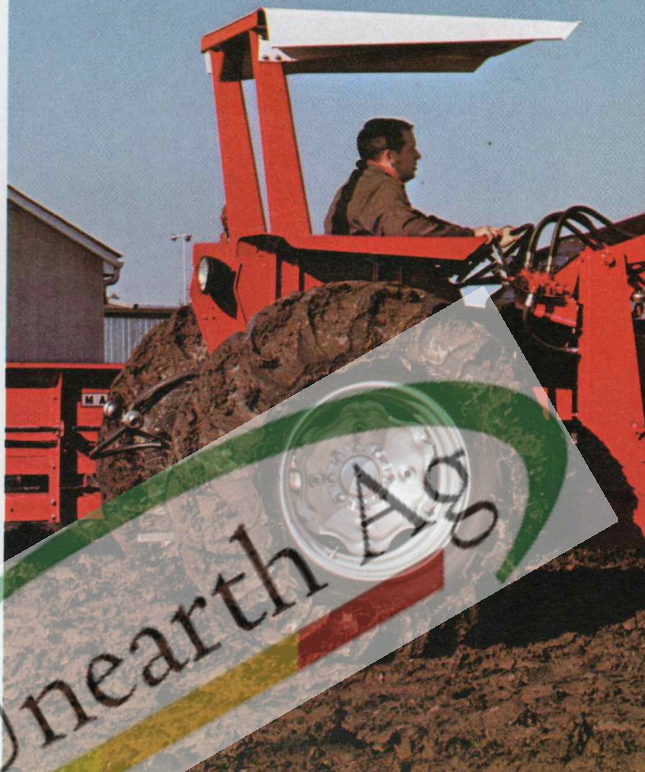
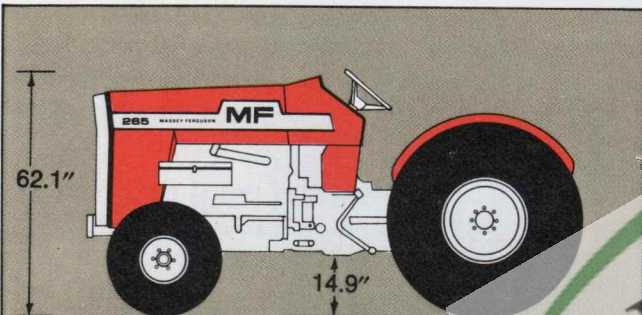



MF265

60 hp – Works fast, stays on the job

When you need a tractor to handle 4-5 plow jobs with real authority, you need a MF 265. Here's real hard-working power in an easy-handling tractor.

Choose a row crop MF 265 with power adjust rear wheel tread and cultivating clearance for row crops. A standard clearance MF 265 for a wide variety of farm jobs. Or a low profile MF 265 that's just right for orchard and grove work.

The MF 265 has a husky 236 cu. in. Perkins diesel engine. Proven 8-speed manual or 12-speed shift-on-the-go Multi-Power transmission. Hydrostatic power steering. Heavy-duty universal drawbar, 3-point linkage, Category II (convertible to Category I). Differential lock. Heavy-duty transmission planetary gear set. Plus many other exclusive MF features.

Options and accessories let you custom-equip an MF 265 to your needs. Choose auxiliary hydraulics with single or dual-spool valve. Safety-skirted flat-top or dished fenders. Vertical or horizontal exhaust. 2-post ROPS for rollover protection. Live or fully independent 540 rpm PTO.

Add up features, reputation, convenience, and economy. You'll find the MF 265 is truly a better tractor value. Find out more about it from your Massey-Ferguson dealer.



Unearth Ag

Pedal travel is more nearly forward for easier operation. Correct steering wheel angle makes driving more comfortable.



Hydrostatic power steering—just like that on larger tractors—gives easy, precise handling.

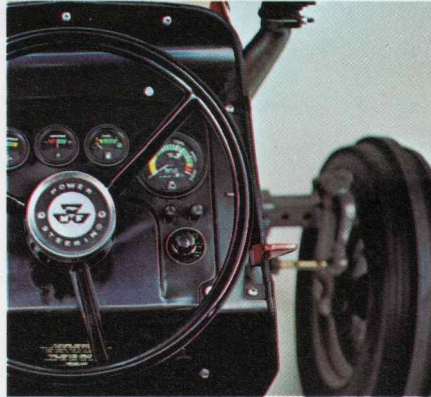

Enjoy a smooth, comfortable ride on this standard molded vinyl cushion seat or the optional deluxe cushion assembly with high, full-width backrest. Both seats are spring suspension mounted with shock absorber.



convenience

...You'll find it from front to back



Unearth Ag

Full set of instruments with universal symbols make operation easier. No warning lights to keep you guessing.

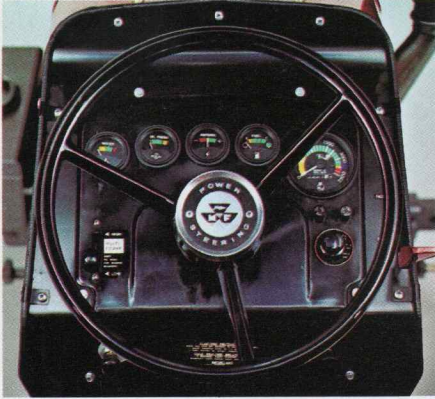

Two headlights in the grille and two in the fenders provide full, even light distribution for night work. Two flashing amber warning lights, and a combination rear work and tail light make night work and travel safer. There's also an SMV emblem bracket.



Convenience means time saving. Easy handling. Safety features. More comfort. Convenience means all this and more on MF 255, MF 265, or MF 275 tractors.

These tractors are designed to be a pleasure to own and operate. Even the good looks help make them more convenient. Example: Grille frame is built rugged. It'll take minor bumps without damage.

Safety-skirted flat-top fenders available on row crop and standard clearance models have a built-in handhold. They offer more protection, too.

And you'll be comfortable with a choice of vinyl cushion or deluxe seat. With either seat, spring suspension mounting soaks up the bumps.

MF convenience gives you complete lighting for safer night work and road travel. There's a swinging drawbar, plus 540 rpm PTO shaft and safety shield. A large toolbox is available to keep tools handy, yet protected.

Big 18.5 gallon fuel capacity along with traditional MF economy mean you'll be ready to stop and eat before the tractor is ready for a refill. And a full set of instruments with universal symbols lets you check performance. There are no warning lights to keep you guessing.

Compare MF convenience features. You'll find MF tractors are good looking and easy and convenient to operate. In fact, you can't beat MF convenience. See for yourself.



Unearth Ag

h

Dual or single spool valve for remote cylinders and big 10 gpm auxiliary hydraulic pump are available. Control 1 or 2 remote cylinders at the touch of a lever.

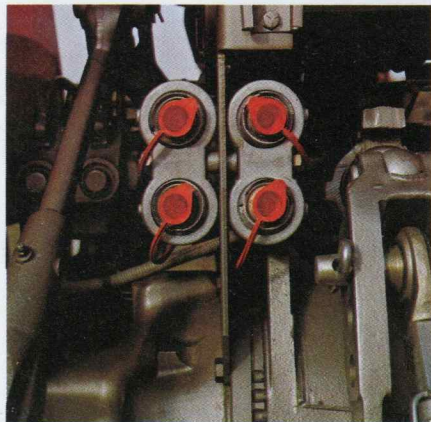

Auxiliary hydraulic filter is located between the remote cylinder couplers and the pump to trap contaminants before they reach the pump, insuring long life. External mounting greatly improves serviceability.

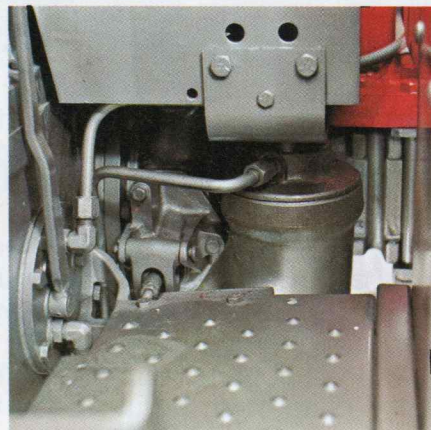

Draft and Position Control, with 3-point linkage for mounted implements are standard on all MF 255, MF 265, and MF 275 tractors.



Unearth Ag

Hydraulics



Now – A new high in performance, convenience, and reliability

You'd expect the best in tractor hydraulics from Massey-Ferguson. MF has been improving hydraulic controls since the original Ferguson System became the industry leader. Now you get a new big-capacity easy-to-service hydraulic system with an MF 255, MF 265, or MF 275 tractor.

Put optional auxiliary hydraulics on any of these tractors, and you get extra-big 19 gpm total capacity. That's more than you'd get on many much larger tractors. The payoff is snappy action with loaders and other high-demand hydraulic equipment.

MF 52 to 67 hp tractors have separate pumps for 3-point hitch, steering, and remote cylinders. There's no short-changing steering when you lift implements. 3-point linkage with Draft and Position Control is standard equipment.

A front-mounted oil cooler and rear-mounted filter with auxiliary hydraulics means better performance and longer life. Grille screen comes off fast for easy access to the oil cooler.

Add up features. Performance. Easy servicing. Reliability. You'll find that now more than ever Massey-Ferguson sets the pace for better-performing tractor hydraulic systems.

Big Capacity

| | |
|------------------------------------|---------------|
| 3-point hitch | 4 gpm |
| Auxiliary hydraulics (optional) | 10 gpm |
| Power steering | 5 gpm |
| Total hydraulic capacity | 19 gpm |

Unearth Ag

MF275

67 hp – Big power, small handling ease

When you need an extra power margin, but can't sacrifice maneuverability and handling ease, an MF 275 is the tractor for your jobs. Here's big-tractor performance with popular straddle-mount design and small-tractor convenience.

The MF 275 is available as a row crop, standard clearance, or low profile tractor. Standard power is a mighty 248 cu. in. 4-cylinder Perkins direct-injection diesel. Engine and drive train are field proven.

Order fully independent PTO, and you get a 12" split-torque clutch for longer life. A pedal designed for forward movement takes less effort to disengage.

Choose 8-speed manual transmission or 12-speed shift-on-the-go Multi-Power.

Heavy-duty planetary final drives and differential lock are standard. Optional auxiliary hydraulics provide big 19 gpm total hydraulic capacity for snappy action with larger equipment this tractor can handle.

Servicing ease and convenience features? The MF 275 has all you'd expect. It's a tractor that's easy to buy and easy to keep on the job.

If you need a tractor that can pour on the power day after day, yet is simple and economical to buy and operate, look at an MF 275.





Standard Clearance (with 16.9-24 tires)

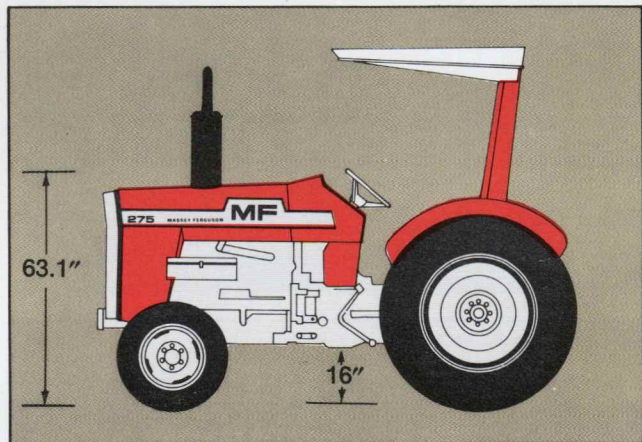

Row Crop (with 15.5-38 tires)

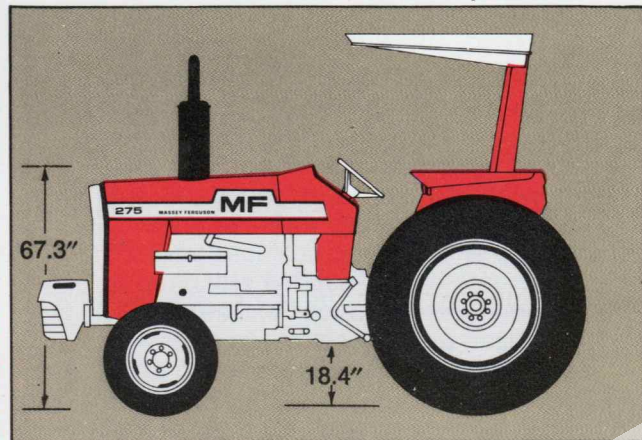

Low Profile (with 16.9-24 tires)

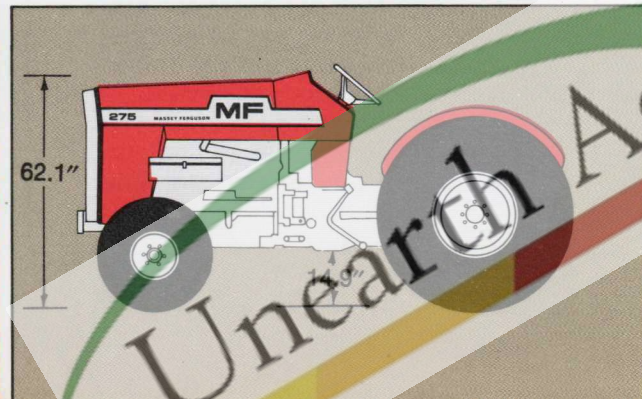

Unearth Ag

engin

Every MF 255, MF 265, and MF 275 has an engine built by Perkins. These engines are known worldwide as rugged, dependable performers on many jobs. What's more, they have a proven record of fuel economy.

You can't look inside an engine to see how sturdy it is. So rest assured that if it's a Perkins, it's built to stay on the job. You get an unbeatable combination of dependability, performance, and economy with Perkins—and Massey-Ferguson.



52 hp* – MF 255

Now you've got it! The MF 255 with the power-packed 236 cu. in. Perkins diesel engine. There's get-up-and-go when you need it. Plus hours of dependable service with sturdy 5-main bearing design. Another extra? Replaceable cylinder sleeves and pistons for almost-instant like-new engine performance.

Proven fuel economy and dependability are built right into the MF 255 with the 236 cu. in. of power that "hangs in there" when the going gets tough.

Line 'em up! Compare! You'll soon see why Perkins is the best of them all.

*Mfg. est.

es



60 hp – MF 265

A top choice is the MF 265 with a powerful 236 cu. in. Perkins diesel engine. There's dependability and economy that's world-renowned.

Rugged 5-main bearing design keeps these engines working dependably hour after hour.

Replaceable cylinder sleeves and pistons on this engine make it possible to restore new-engine performance after thousands of hours service.

The direct-injection diesel starts easily. Effective filtration protects the fuel system from dirt. This engine upholds the Perkins reputation for fuel economy, too.

Look for rugged design. Economy. Dependability. You'll find it all with a Perkins-powered MF 265.

67 hp – MF 275

A load-lugging 248 cu. in. Perkins diesel gives the MF 275 extra power for tough jobs. This is an engine that has proven itself in thousands of applications around the world. And it's an economy leader.

Big 3.975" bore and 5" stroke make this 4-cylinder power plant a real work-horse. Like other Perkins diesels, it's built rugged. You get day after day of dependable service.

Features like replaceable cylinder sleeves and 5-main bearing design add up to dependability. Direct-injection design is simple, and gives excellent fuel economy. Starts easily, too.

Larger cylinders give this engine extra stamina for tough jobs. Reserve lugging power at reduced rpm means better performance in the field.

Get Perkins dependability and economy in an engine that has a clear-cut lead in performance. Get a MF 275 with this 248 cu. in. Perkins diesel.

Unearth Ag

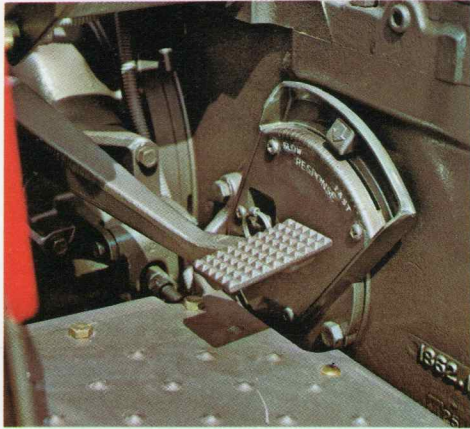

Differential lock powers you through the tough spots by locking both rear wheels together.

Live or fully-independent 540 rpm PTO has new beefed-up internal components. Long PTO and drawbar meet latest ASAE/SAE standards.

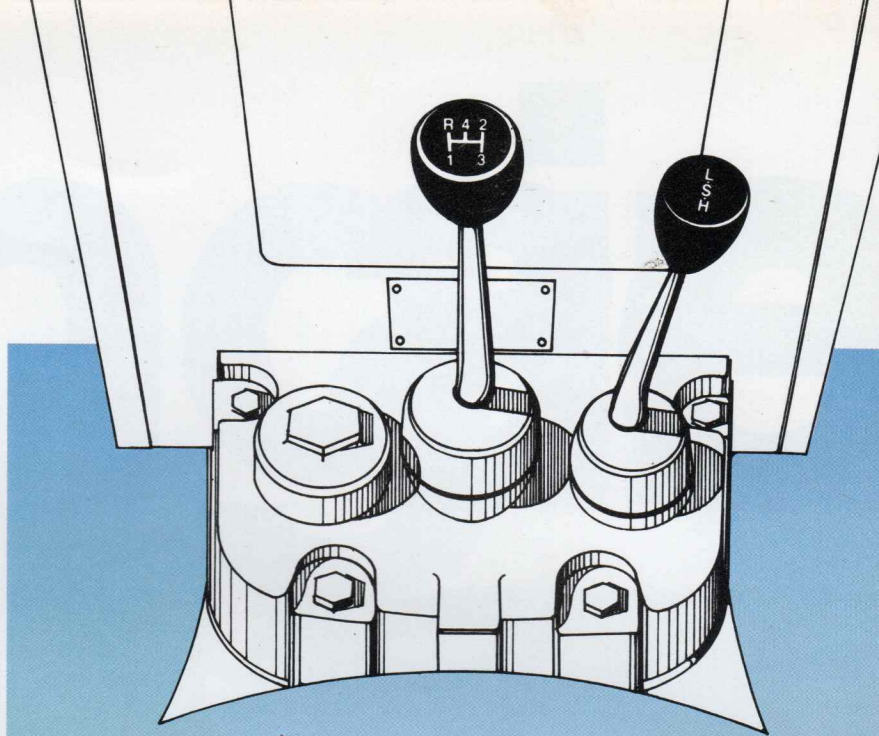
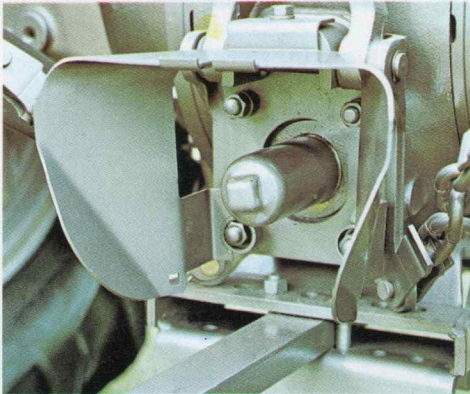

transmis

Unearth Ag

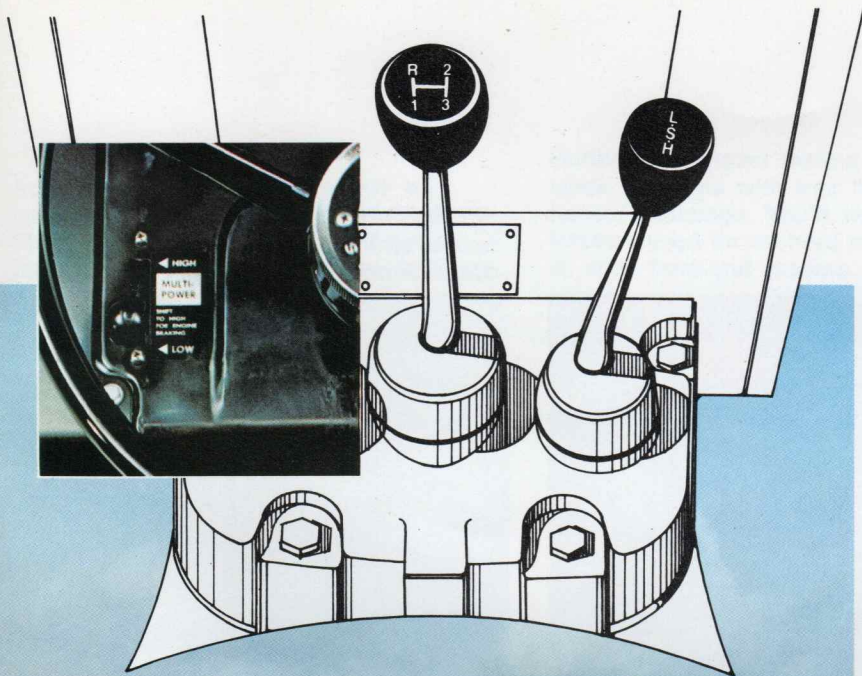

Take your choice of improved 8-speed or 12-speed Multi-Power

Massey-Ferguson gives you a choice of either transmission in any MF 255, MF 265, or MF 275 tractor.

With the MF 8-speed transmission you'll find a better range of working speeds to match your exact needs in the field. And there's a new, faster top speed to make road travel more convenient, too.

Multi-Power gives shift-on-the-go convenience at the touch of a lever. Slow down for tough spots or turns, speed up again when the going gets easier. All without touching the clutch.

Optional live or fully-independent 540 rpm PTO is available with either transmission. Big 8 $\frac{3}{4}$ " double-disc brakes operate with new forward-moving pedal action.

Differential lock operates at the touch of a foot pedal. It's standard on every MF 255, MF 265, and MF 275.



sions



Custom-fit MF power to your needs

Take time to let your MF dealer show you the benefits of MF options and accessories. A properly-equipped tractor is worth more to you when it's new. And it'll be worth more at trade-in time. Besides engine, power train, and hydraulic options, you'll want to look over these features for faster, easier farming.

MF Saf-T-Frame is a 2-post rollover protective structure. Canopy shields an MF operator from hot sun.

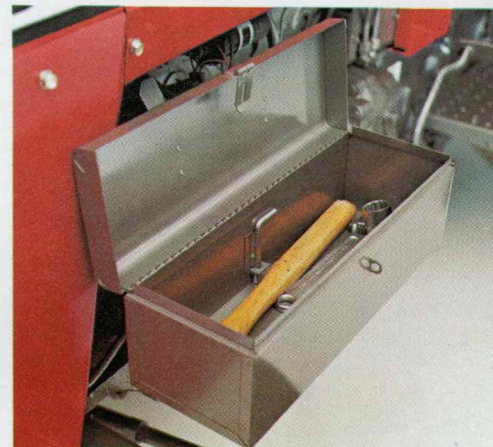
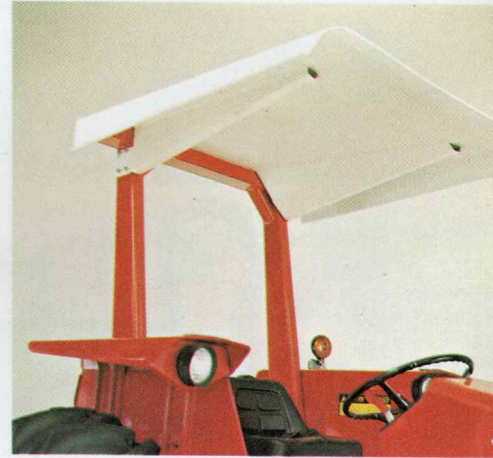

Big tool box protects valuable tools, yet keeps them within easy reach for field adjustment. Weatherproof lid can be locked.

options & a

Unearth Ag

Add extra stability and traction with easy-to-handle "suitcase" weights. They fit snugly on the standard front weight frame. Rear wheel weights also available.



Horizontal exhaust means no upright stack to tangle with tree limbs or low-framed buildings. You'll want this option on tractors used for orchard and grove work, or with front-end loaders.

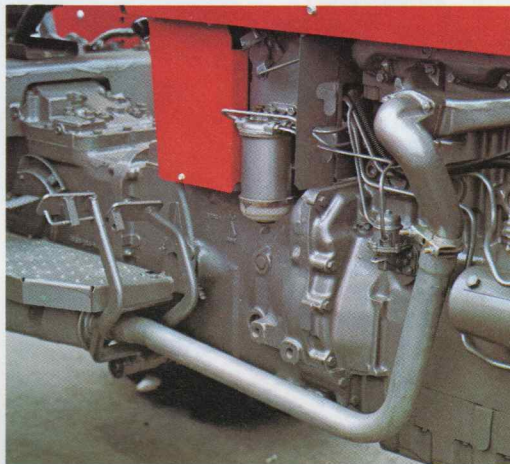

Take your choice from a wide selection of front tires to fit your applications.

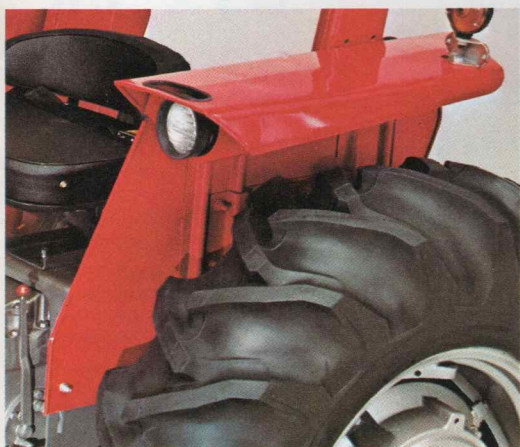

Flat-top skirted fenders are more convenient and offer greater protection. Hand holds make it easier to get onto the tractor. Standard on row crop and optional on standard clearance models.



Power adjust rear wheels let engine power do the heavy work. No lifting or tugging or hammering to move heavy fluid-filled tires. Available with either stamped steel or cast centers and a variety of tire sizes.



For comfort-plus select this deluxe cushion seat with high full-width backrest. It's mounted on a Knoedler-type spring suspension for a smooth, comfortable ride.

ccessories

Unearth Ag

specifica

MF 255

ENGINE

Model: AD 4.236 Perkins diesel.
Cylinders: Four.
Bore & stroke: 3.87 x 5.00"
(9.83 x 12.7 cm).
Displacement: 236 cu. in.
(3.87 l).
Compression ratio: Diesel 15:1.
Cylinder sleeves: Dry
replaceable.
Number of main bearings: Five.
Rated speed: 2000 rpm
Horsepower: 52 PTO horse-
power at 2000 engine rpm
(Nebr. test.).

CLUTCH

11" (27.94 cm) diameter split-
torque with independent PTO.
9"-11" (22.86-97.94 cm) dual
with live PTO.

FINAL DRIVE

Planetary. Foot-operated
differential lock.

HYDRAULICS

Category I 3-point linkage
(convertible to Category II).
Draft Control, Position Control
standard.

LINKAGE LIFT CAPACITY

3800 lbs. (1725 kg). (SAE
J715B rating).

CAPACITIES

Fuel: 18.5 U.S. gal., 15.4 Imp.
gal. (70.0 l).
Radiator: 11 U.S. qt., 9.2 Imp.
qt. (10.4 l).
Engine crankcase: 8.0 U.S. qt.,
6.7 Imp. qt. (7.6 l).
Hydraulic system: 8 U.S. gal.,
6.7 Imp. gal. (30.3 l).

WEIGHT (approximate minimum)

Diesel: 5850 lbs. (2653 kg).

| TIRES | Standard Clearance | Row Crop | Low Profile |
|-------|-----------------------|-------------|----------------|
| Rear | 16.9-24 | 13.6-38 (4) | 14.9-24 |
| | 16.9-26 | 13.6-38 (6) | 16.9-24 |
| | 16.9-28 | 15.5-38 | 18.4-16.1 R-1 |
| | 16.9-30 | 14.9-38 | 18.4-16.1 R-3 |
| | 18.4-26 R-1 | | 21.5L-16.1 |
| | 18.4-26 R-3 | | |
| Front | 6.00-16 | 5.50-16 | 6.00-16 |
| | 6.50-16 (4) | 6.00-16 | 6.50-16 |
| | 6.50-16 (6) | 6.50-16 (4) | 7.50-10 |
| | 7.5L-15 | 6.50-16 (6) | 9.5L-10 |

MF 265

ENGINE

Model: AD4.236 Perkins diesel
Cylinders: Four.
Bore & stroke: 3.87 x 5.0"
(9.83 x 12.7 cm).
Displacement: 236 cu. in.
(3.87 l).
Compression ratio: Diesel 15:1.
Cylinder sleeves: Dry
replaceable.
Number of main bearings: Five.
Rated speed: 2000 rpm.
Horsepower: 60 PTO horse-
power at 2000 engine rpm
(Nebr. test.).

CLUTCH

11" (27.94 cm) diameter split-
torque with independent PTO.
9"-11" (22.86-97.94 cm) dual
with live PTO.

FINAL DRIVE

Heavy-duty planetary. Foot-
operated differential lock.

HYDRAULICS

Category II 3-point linkage
(convertible to Category I).
Draft Control and Position
Control standard.

LINKAGE LIFT CAPACITY

4100 lbs. (1861 kg). (SAE
J715B rating).

CAPACITIES

Fuel: 18.5 U.S. gal., 15.4 Imp.
gal. (70.0 l).
Radiator: 11 U.S. qt., 9.2 Imp.
qt. (10.4 l).
Engine crankcase: 8.0 U.S. qt.
6.7 Imp. qt. (7.6 l).
Hydraulic system: 8 U.S. gal.,
6.7 Imp. gal. (30.3 l).

WEIGHT (approximate mini- mum)

6100 lbs. (2766 kg).

| TIRES | Standard Clearance | Row Crop | Low Profile |
|-------|-----------------------|-------------|----------------|
| Rear | 16.9-24 | 13.6-38 (6) | 14.9-24 |
| | 16.9-28 | 14.9-38 | 16.9-24 |
| | 16.9-30 | 15.5-38 | 18.4-16.1 R- |
| | 18.4-26 | 18.4-30 | 18.4-16.4 R- |
| | | | 21.5L-16.1 |
| Front | 6.00-16 | 6.50-16 (4) | 6.00-16 |
| | 6.50-16 (4) | 6.50-16 (6) | 6.50-16 (4) |
| | 6.50-16 (6) | 7.5L-15 | 6.50-16 (6) |
| | 7.5L-15 | | 7.50-10 |
| | | | 9.5L-10 |

tions

MF 275

ENGINE

Model: AD 4.248 Perkins direct-injection diesel.
Cylinders: Four.
Bore & stroke: 3.975 x 5.0" (10.10 x 12.7 cm).
Displacement: 248 cu. in. (4.06 l).
Compression ratio: 16:1.
Cylinder sleeves: Dry replaceable.
Number of main bearings: Five.
Rated speed: 2000 rpm.
Horsepower: 67 PTO horsepower at 2000 engine rpm (Nebr. test.).

CLUTCH

12" (30.5 cm) diameter split-torque with independent PTO.
10-12" (25.4-30.5 cm) dual with live PTO.

FINAL DRIVE

Heavy-duty planetary. Foot-operated differential lock.

HYDRAULICS

Category II 3-point linkage (convertible to Category I). Draft Control, Position Control standard.

LINKAGE LIFT CAPACITY

4100 lbs. (1861 kg). (SAE J715B rating).

CAPACITIES

Fuel: 18.5 U.S. gal., 15.4 Imp. gal. (70.0 l).
Radiator: 11 U.S. qt., 9.2 Imp. qt. (10.4 l).
Engine crankcase: 8.0 U.S. qt., 6.7 Imp. qt. (7.6 l).
Hydraulic system: 8 U.S. gal., 6.7 Imp. gal. (30.3 l).

WEIGHT (approximate minimum)

6100 lbs. (2766 kg).

| | Standard Clearance | Row Crop | Low Profile | |
|--------------|--------------------|--|--|--|
| TIRES | | | | |
| | Rear | 16.9-24 16.9-28 16.9-30 18.4-26 | 13.6-38 (6) 14.9-38 15.5-38 18.4-30 | 14.9-24 16.9-24 18.4-16.1 R-1 18.4-16.1 R-3 21.5L-16.1 |
| | Front | 6.00-16 6.50-16 (4) 6.50-16 (6) 7.5L-15 | 6.50-16 (4) 6.50-16 (6) 7.5L-15 | 6.00-16 6.50-16 (4) 6.50-16 (6) 7.50-10 9.5L-10 |

GROUND SPEEDS

MF 255 (14.9-28 rear tires, 2000 engine rpm).

8-speed manual transmission:

Forward: (mph) 1.41, 2.07, 3.80, 4.66, 5.65, 8.28, 15.18, 18.63. (km/h) 2.26, 3.33, 6.12, 7.50, 9.09, 13.33, 24.43, 39.98.
Reverse: (mph) 1.93 and 7.70. (km/h) 3.11 and 12.39.

12-speed Multi-Power transmission:

Forward: (mph) 1.32, 1.72, 1.93, 2.53, 3.54, 4.63, 5.27, 6.89, 7.73, 10.11, 14.17, 18.54. (km/h) 2.12, 2.77, 3.11, 4.07, 5.70, 7.45, 8.48, 11.09, 12.44, 16.27, 22.80, 29.84.
Reverse: (mph) 1.79, 2.34, 7.18, 9.37. (km/h) 2.88, 3.77, 11.56, 15.08.

MF 265/275 (16.9-28 rear tires, 2000 engine rpm)

8-speed manual transmission:

Forward: (mph) 1.45, 2.12, 3.89, 4.77, 5.68, 8.49, 15.55, 19.10. (km/h) 2.33, 3.41, 6.26, 7.68, 9.14, 13.66, 25.02, 30.74.
Reverse: (mph) 1.98 and 7.88. (km/h) 3.19 and 12.68.

12-speed Multi-Power transmission:

Forward: (mph) 1.35, 1.76, 1.98, 2.59, 3.64, 4.75, 5.40, 7.05, 7.92, 10.36, 14.50, 19.00. (km/h) 2.21, 2.88, 3.24, 4.24, 5.96, 7.78, 8.85, 11.55, 12.97, 16.97, 23.75, 31.12.
Reverse: (mph) 1.84, 2.40, 7.36, 9.60. (km/h) 3.01, 3.93, 12.06, 15.73.

MF 255/265/275

TRANSMISSION

Type: 8-speed manual or 12-speed Multi-Power.
Number of speeds: 8 forward, 2 reverse with manual. 12 forward, 4 reverse with Multi-Power.
On-the-go shifting: With Multi-Power only; boosts power up to 26% without use of foot clutch.

STEERING

Hydrostatic power.

TURNING RADIUS

Approximately 12' (3.66 m) without brakes.

BRAKES

8 $\frac{3}{4}$ " (22.2 cm) diameter, oil immersed disc.

AUXILIARY HYDRAULICS

Available with separate pump, 10 gpm (27.9 l/min.) maximum flow at outlets, 2300 psi (162 kg/cm²). Single or dual-spool valves available.

HYDRAULIC PUMPS

Four-piston Scotch Yoke for 3-point linkage. 4 gpm (15.1 l/min.) at 3000 psi (210.9 kg/cm²). Gear pump for auxiliary hydraulics (optional). 10 gpm (37.9 l/min.) at 2300 psi (161.7 kg/cm²). Gear pump for steering, 5 gpm (18.9 l/min.) at 650 psi (45.70 kg/cm²). Total capacity all three pumps: 19 gpm (71.9 l/min.).

ELECTRICAL SYSTEM

12-volt. Front-mounted 180 amp/hr battery. 37 amp alternator with integral voltage regulator.

LIGHTS

Four headlamps, two flashing amber warning lamps, and one combination work and tail lamp.

| | Standard Clearance | Row Crop | Low Profile | |
|--------------------|--------------------|---------------------|--------------------|--------------------|
| DIMENSIONS | | | | |
| | Wheelbase | 82" (208cm) | 82" (208cm) | 82" (208cm) |
| | Rear tread | 56-90" (142-229 cm) | 56-90" (142-229cm) | 55-87" (140-221cm) |
| Front tread | 48-72" (122-183cm) | 52-76" (132-193cm) | 48-72" (122-183cm) | |

parts, service, financing...

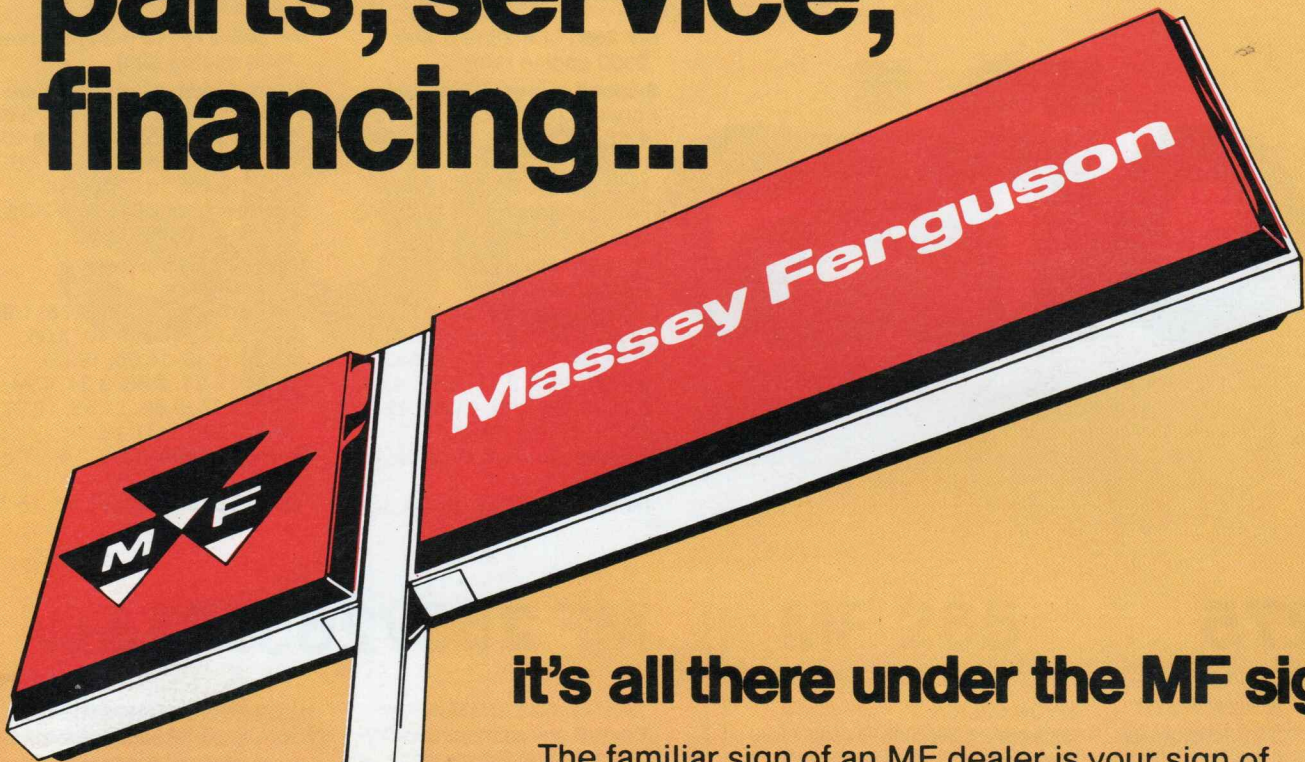

it's all there under the MF sign

The familiar sign of an MF dealer is your sign of better machinery value. MF financing plans can help you buy the machinery you need. And MF parts and service will help you keep machinery working at top efficiency.

At an MF dealer you'll find an unmatched choice of financing plans. Local service and computerized parts delivery hold "downtime" to a minimum. Choose MF for satisfaction on delivery day—and for a long time after. Your MF dealer is ready and willing to help you choose the machinery you need. Let him show you how easy it is to go Massey-Ferguson. See him soon!

MF Massey Ferguson

MATTOON FARM SERVICE
Massey Ferguson and Bobcat
Route 316 and Ferna Road
P. O. Box 981
Mattoon, Illinois 61938
217-235-7131

Unearth Ag