

# Ford 4550

## Excavator/Loaders



# Ford 4550 unit.

## Ford Construction Equipment

From long experience based on manufacturing, operating and servicing industrial and construction machinery, Ford have designed and developed the versatile 4550 range of excavator/loaders.

For years Ford machines have won an enviable reputation for toughness and reliability in difficult conditions.

Designed by engineers who are familiar with the varied requirements of plant hire, contracting and civil engineering, Ford rigs are manufactured to the highest standards using the combined and specialist skills of men and machinery in plants throughout the world.

Ford units are supported by a comprehensive and thoroughly efficient nationwide sales and service network.

You can choose a Ford 4550 with confidence. You'll be getting a functional, thoroughly proven, high quality product backed by the name, reputation and the resources of the Ford Motor Company.

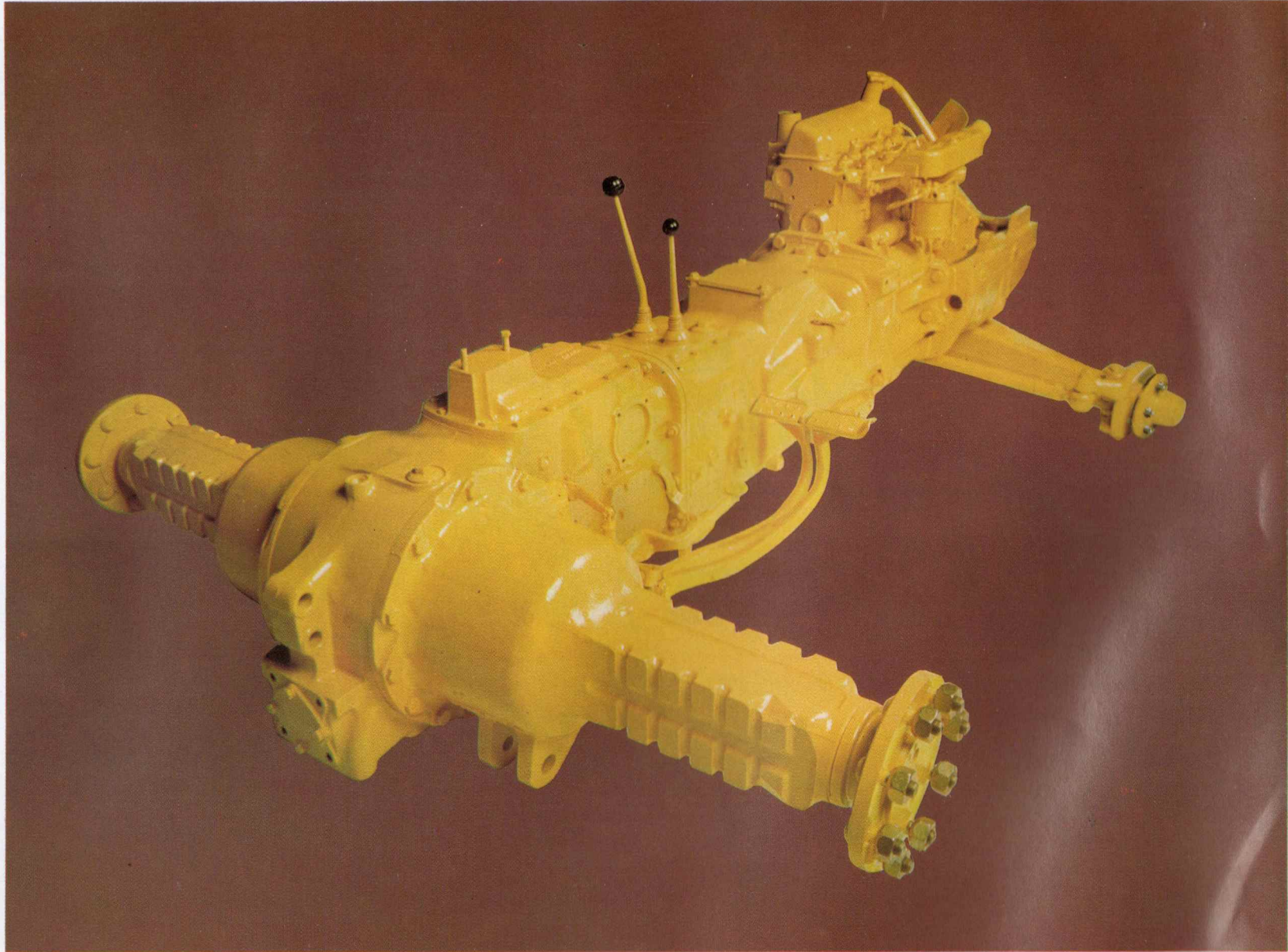

## FORD 4550 POWER UNIT

Designed and built with great integral strength, this power unit forms the basis of all Ford 4550 machines.

Intended for the rigours of the construction and plant hire industries, the massive power unit gives the basic strength and rigidity to all 4550 machines and helps to withstand the heavy stresses encountered daily on your site.

In every aspect the 4550 unit reflects Ford engineers' concern for long life, simple service and suitability for the job.

## Engine

Rugged Ford 3-Cylinder, 3,294 cc (201 cu. in.) direct injection diesel, with cross-flow cylinder head and 4 bearing crankshaft. Purpose-designed for heavy duty work.

60 bhp (DIN) at 2,200 rev/min (62 bhp BS AU141a) and 21.0 m/kg (163 lbs. ft.) torque at only 1300 rpm provides power and flexibility to maximise work output, especially front shovel work.

Outstanding accessibility, including swing-out battery and quick service dry element air filter, ease servicing and reduce downtime.

## Gearbox

Special heavy duty 13" single plate clutch with external greaser, designed for long service life with light pedal pressure.

Standard constant mesh industrial gearbox with 6 forward and 4 reverse speeds, designed to match all on-site and transport requirements.

A sensible gearshift pattern (A) places the 4 main forward working speeds in line with the equivalent reverse ratios for fast shuttling. A safety start feature permits unit to start only in neutral. Speeds in mph for manual transmission machine on 14 x 28 tyres.

A torque converter power-reversing transmission with 4 forward and 4 reverse speeds is optional and fingertip directional changes give fatigue-free working and reduced tyre wear. A safety "blockout" valve prevents transmission overload when shuttling.

## Rear Axle

A massive industrial rear axle (B) incorporates double reduction, inboard planetary drive and deep induction hardened half-shafts.

Oil-immersed multi-disc brakes, sealed against dirt and water, give powerful fade-free stopping power with low pedal effort and negligible maintenance. Independent operation assists manoeuvrability. Standard pedal-operated differential lock (C) maximises traction in difficult conditions, increases output and reduces tyre wear.

Axle ratio 15.75:1. Ground Clearance 54.3 cm (21.4"). Track Width 162.5 cm (64").

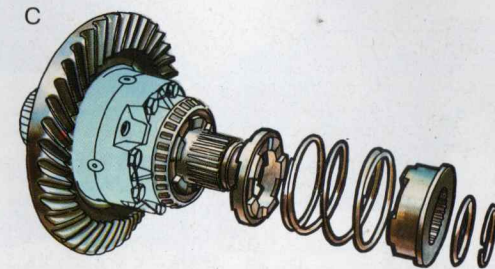
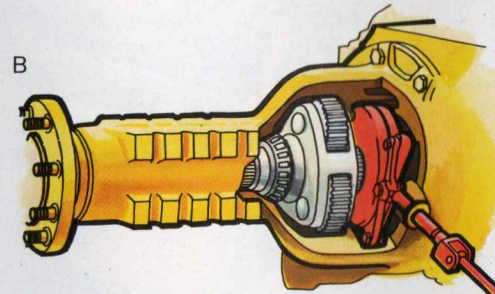
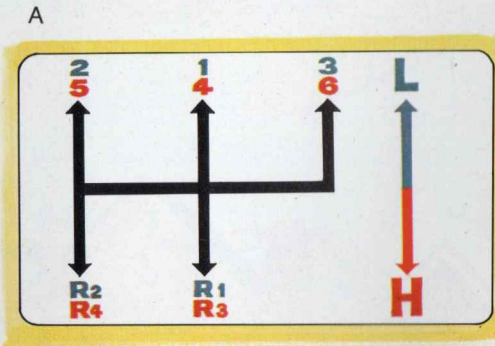

## Integral Strength

The enormously strong engine, gearbox and rear axle castings give the whole power unit (D) great integral strength, eliminating the need for a cumbersome separate chassis.

The specially designed subframe evenly distributes loadings throughout the power unit to avoid local over-stressing.

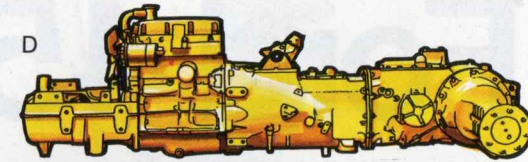

## Front End Assembly

A heavy duty front end with 1.2 cm (1/2") steel plate radiator shroud and grille, plus heavy front axle support casting, give maximum protection (E) to radiator and hydraulic pump.

A single piece box beam construction front axle (F) ensures maximum strength without excess weight. The swept back design gives outstanding manoeuvrability. Tough truck type axle spindles give long service life and positive steering control. Ground Clearance 30.48 cm (12.0"). Track width 142 cm (56").

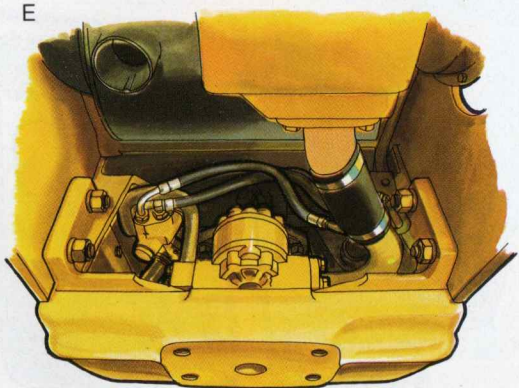

## Hydraulics

A high performance crankshaft driven gear pump delivers 102 litres (22.5 imp galls) per min at 2200 rev/min ensuring fast and powerful loading and digging. Matched pump performance also allows powerful digging even at low engine speeds. The excavator working pressure is 154 kg/cm<sup>2</sup> (2250 lbs psi). The loader working pressure is 137 kg/cm<sup>2</sup> (1950 lbs psi). The pump is well protected within the front axle support casting. The hydraulic system capacity is 83 litres (18.3 imp galls) with the subframe members serving as hydraulic reservoirs and assisting oil cooling.

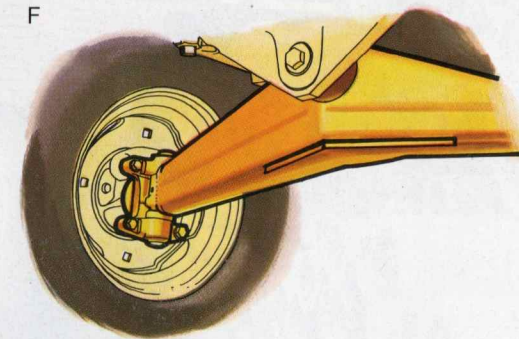

## Steering

Standard power-assisted steering uses an engine driven pump with a separate hydraulic system. Light, positive steering reduces operator fatigue. The steering ram is fully protected by the front axle support casting.

Turning circle using brakes 560 cm (22' 0"); without brakes 620 cm (24' 4").

## Tyres

Standard front: 7.50 x 16 8-ply Earthmover  
Optional front: 9.00 x 16 10-ply 3 rib or 5 rib  
Standard rear: 14.00 x 28 8-ply R1  
Optional rear: 14.00 x 28 8-ply Haul Champion

## Dimensions

Wheelbase 203 cm (6' 7 1/2").

# Ford 4550 loader



## FORD 4550 LOADER

The loader fitted to this powerful and versatile machine is also fitted to the Ford 4550 Excavator/Loader range. The Ford 4550 Industrial Loader with its high strength-to-weight ratio, is built to last and to take on the toughest jobs. Here is a loader that will take on loading, dumping, dozing, lifting, transporting, grading, site-stripping, snow clearing and road cleaning work. And still come back for more.

### Construction

Special Ford high tensile steel reduces equipment weight without affecting strength and allows optimum utilisation of hydraulic power. Large box section cross member (G) ensures loader rigidity and prevents twisting under severe and uneven loading stresses. Lift ram cylinder diameter 7.62 cm (3"); rod diameter 5 cm (2"). Bucket ram cylinder diameter 7.62 cm (3"); rod diameter 3.81 cm (1.5").

### Self-levelling

Standard hydraulic self-levelling (H) prevents spillage and allows safer full height loading operations. The absence of mechanical linkage means fewer moving parts and less wear and tear.

### Performance Data

Maximum loading height 310 cm (10' 9").  
Full height lift capacity 2,041 kg (4,500 lbs).  
Maximum breakaway capacity 3,225 kg (7,110 lbs).  
Maximum operating pressure 137 kg/cm<sup>2</sup> (1,950 lbs psi).  
Fast bucket cycle times: lift to full height 4.5 secs; dump 1.7 secs; lower 2.7 secs. (empty bucket).  
Reach at ground level 183 cm (6' 0").  
- at full height with dumped bucket 67 cm (2' 2½").  
Lift clearance with dumped bucket 262.9 cm (8' 7½").  
Maximum dump angle 37°.  
Roll back at ground level 35°.  
Digging depth 10 cm (4") - on 7.50 x 16 front tyres.

### Loader Control Valve

A two lever control valve (I) provides simple and positive movement of the loader lift and crowd rams. A separate valve isolates the self-levelling system when dozing, levelling and site stripping. A float position allows the bucket to follow ground contours without penetration and assists snow

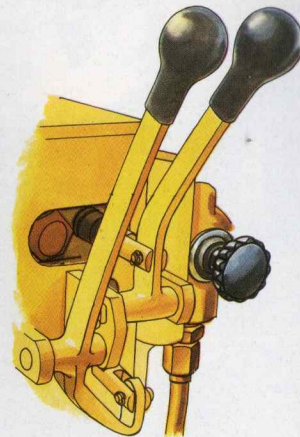
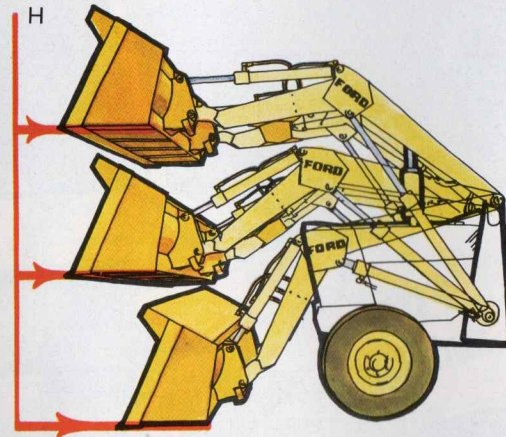
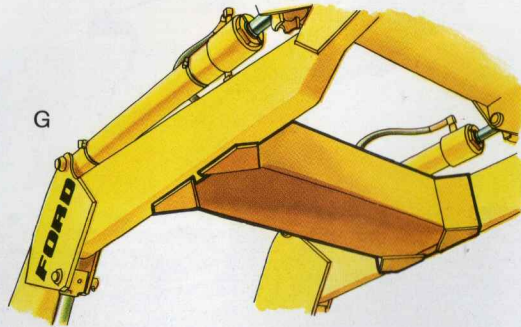

clearance, road cleaning and back blading. The control valve also incorporates the system pressure relief valve. Relief valve setting 137 kg/cm<sup>2</sup> (1,950 psi).

### Oil Reservoir Header Tank

A large capacity header tank directly above the hydraulic pump guards against pump starvation on sloping sites and permits instant oil level checks. Double oil filtration increase component life and the filter (J) is readily accessible for quick inspection and servicing.

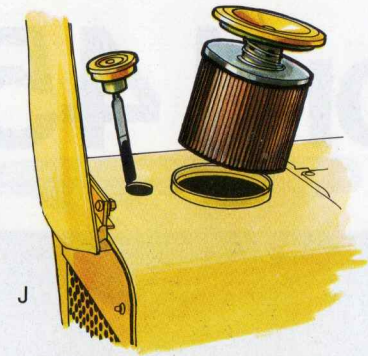

### Buckets

A large 860 litres (1 cu yd) tread width bucket is fitted as standard. A 765 litres (7/8 cu yd) bucket is available if required, plus alternative attachments for specialised applications and materials. All buckets feature curved contours for easy filling and fast dumping. Hardened cutting edges and wear strips (K) ensure great durability. Teeth are available for all buckets. A specially designed heel on the rear edge of the standard bucket allows efficient levelling when unit is operated in reverse.

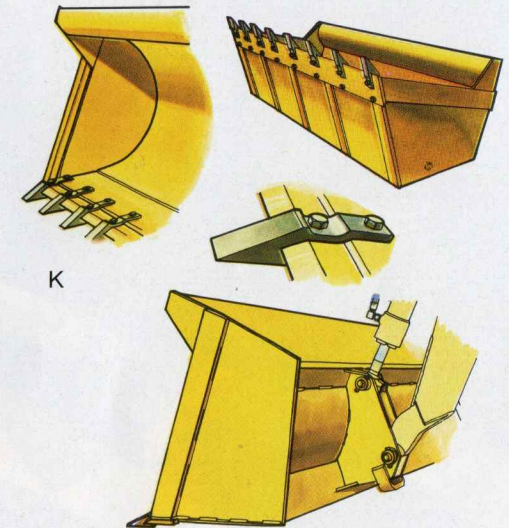

### Safety Cab

Standard on all 4550 Loaders, the Ford Safety Cab offers a safe and controlled operating environment, exceptional visibility, efficient ventilation, generous headroom and many additional operator comforts. This cab conforms to OECD C(70)9 and BS 4063 crush and impact test requirements providing the operator with optimum safety protection at all times.

### Operating Ballast

A substantial counter weight box (L) is supplied with each Ford 4550 Loader. Heavy cast wheel weights are also fitted as standard to assist traction when working with heavy materials or on poor surfaces.



# Ford 4550 side shift.



## FORD 4550 SIDESHIFT

This is a high performance Excavator/Loader incorporating tremendous in-built strength and offering swift and simple offsetting of the excavator to any point on the main frame. The same loader is used as on the 4550 Industrial Loader.

This sideshifting ability makes trenching easier in inaccessible corners, alongside walls and for specialist tasks such as digging out pavements, where space to manoeuvre is often at a premium. With its high strength-to-weight ratio, powerful hydraulics and low stress factors, the Ford 4550 Excavator/Loader is a high output, dependable digging unit.

## Boom and Dipperstick Construction

The closed box section construction (M) resists twisting and distortion and additional strength is provided by welded gussets at the ends of the boom and dipperstick.

Special Ford high tensile steel gives added strength to the boom and dipperstick, but without adding power consuming weight.

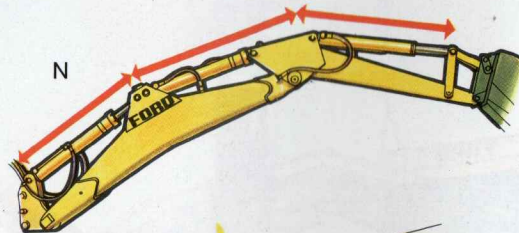
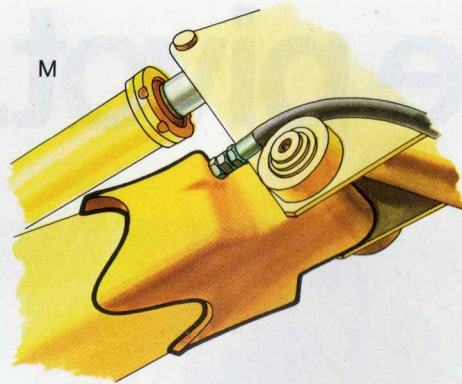

## Hydraulic Rams

The in-line hydraulic ram layout (N) spreads operating stresses evenly, prevents distortion of the boom and increases digging power. All rams and digging components are protected from shock loadings by circuit relief valves.

Lift ram cylinder diameter 10.2 cm (4.0");

rod diameter 5.0 cm (2.0").

Crowd ram cylinder diameter 10.2 cm (4.0");

rod diameter 5.0 cm (2.0").

Bucket ram cylinder diameter 8.8 cm (3.5");

rod diameter 6.3 cm (2.5").

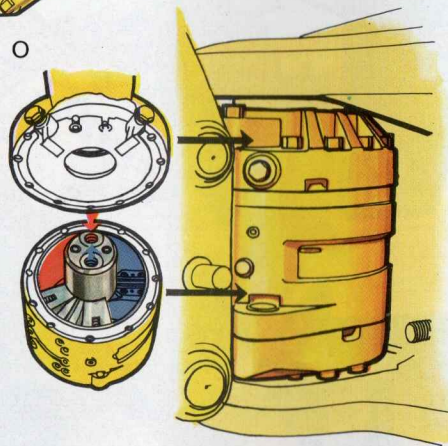

## Swing Motor

A powerful swing motor (O) provides constant slewing effort through 182°. Full buckets can be swung uphill with ease both at high and low engine speeds.

Automatic deceleration slows boom swing at travel limits and cushions boom and subframe components against unnecessary shocks.

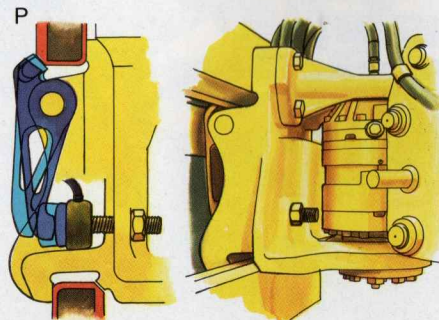

## Offsetting

Rapid offsetting of the excavator is assisted by the use of Hydraulic Clamping (P). Movement of a single lever within the cab locks and unlocks the excavator on the main frame. Trenching alongside kerbs, walls and other obstructions is therefore, made extremely easy.

Max offset - 64 cm (2' 6").

## Stabilisers

Vertical stabilisers provide excellent stability even on rough and undulating surfaces and are independently adjustable from inside the cab. Reversible pads give operating widths of 239 cm (7' 10") or 273 cm (8' 11½").

## Controls

4 simple levers (Q) control all digging and slewing actions. Light to use, they provide precise and accurate control of the excavator coupled with maximum safety.

Optional Auto-dig, provides semi-automatic hydraulic digging control and cuts operator fatigue on bulk excavations. A remote throttle control mounted on the control console allows engine speed to be varied from the operator's seat. Control valve - 6 spool open centre.

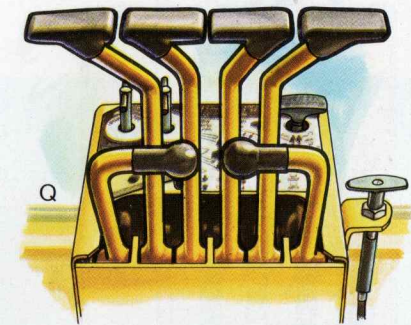

## Performance Data

Maximum digging depth 411 cm (13' 6").

Loading height 310 cm (10' 2").

Reach from swing post 535 cm (17' 6½").

Reach from centre line of rear axle 655 cm (21' 3").

Max bucket rotation 186°.

Maximum digging force with standard bucket:

crown cylinder 2,431 kg (5,820 lbs); bucket cylinder

3,764 kg (8,300 lbs).

Maximum tearout force at bucket 4,263 kg (9,400 lbs)

Maximum operating pressure - 154 kg/cm<sup>2</sup> (2,250 lbs p.s.i.).

## Buckets

A wide range of buckets (R) is available for all trenching requirements.

Widths from 30.5 cm to 91.4 cm (12" to 36").

Capacities from 70 litres to 230 litres (2.7 cu ft to

8.2 cu ft). Buckets are shaped for fast efficient

filling and dumping. The knock-on teeth are easily replaceable and feature a special wear-sharp cutting edge.

The 4-bar bucket linkage system provides an alternative position for "power" digging in hard conditions and ensures constant power crowding action throughout full arc of bucket rotation.

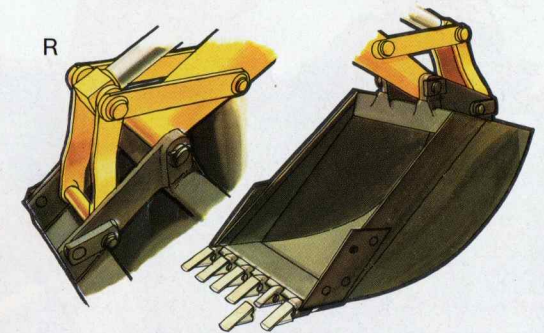

## Cab

Designed for the operator, this cab is based upon an immensely strong safety frame (S) conforming to O.E.C.D. C(70)9 and B.S. 4063 impact and crush test requirements.

Exterior features include integral front and rear working lights; laminated safety glass front windscreens and a full size door for easy entry and exit.

Interior features include twin, fully adjustable comfort seats; full weathersealing; powerful fresh air heater/defroster unit, generous headroom, exceptional visibility, tool kit, interior light and rubber floor mats.

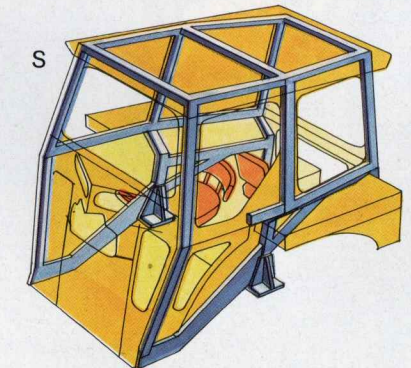

# Ford 4550 centre pivot.



## FORD 4550 CENTRE PIVOT

This long reach Centre Pivot Excavator/Loader incorporates all the operator benefits of the Ford 4550 Sideshift, plus specific additional features which make it an ideal machine for high output and profit. It also uses the same loader as the 4550 Side Shift.

The Ford 4550 Centre Pivot can make full use of its extra reach and capacity, thanks to the exceptional stability provided by the swept back configuration of the stabilisers and the proven design of its digging components.

### Boom and Dipperstick Construction

Using the same highly successful box section design as the 4550 sideshift, the boom and dipperstick of the 4550 Centre Pivot have additional heavy duty gussets (T) for even greater strength. The same special Ford high tensile steel is used to give maximum strength with minimum weight, and puts available hydraulic power to the best possible use.

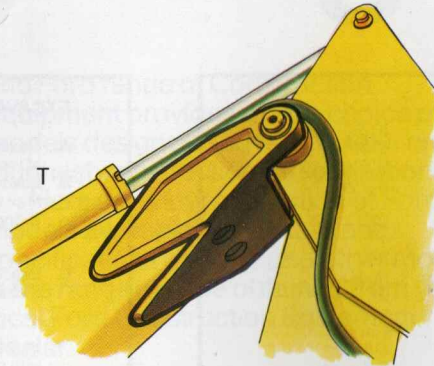

### Hydraulic Rams

The ram design and layout (U) ensures even distribution of operating stresses and gives maximum power to digging components for fast and powerful bucket work at all depths. All cylinders are externally mounted for easy servicing. Circuit relief valves protect rams and digging components from shock loads.

Lift cylinder diameter 11.4 cm (4.5"); rod diameter 5.0 cm (2.0").

Crowd ram cylinder diameter 11.4 cm (4.5"); rod diameter 5.7 cm (2.25").

Bucket ram cylinder diameter 8.8 cm (3.5"); rod diameter 6.3 cm (2.5").

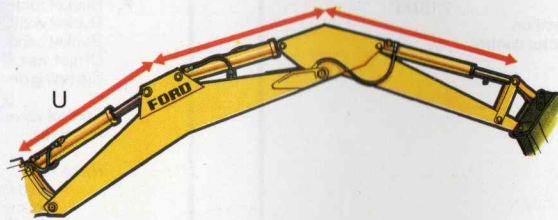

### Slewing System

A rugged, multi-link steel band and piston type swing mechanism (V) gives powerful slewing action through 185°. A mechanical swing decelerator system gives full protection against overloads.

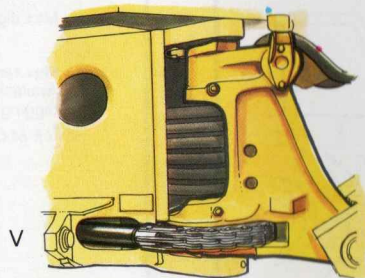

### Stabilisers

Independently adjustable swept back stabilisers (W), angled for extra stability, give a maximum working width of 310 cm (10' 2") yet are retractable within the width of the unit for transportation. Optional stabiliser pads are available for all applications and surfaces.

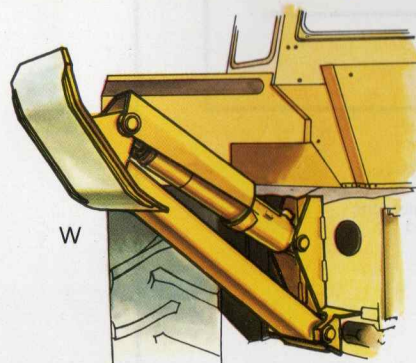

## Controls

4 levers ensure precise, accurate control of all digging and slewing operations, coupled with high output and maximum safety.

Optional Auto-dig (X) provides semi-automatic digging control and cuts operator fatigue on bulk excavations. A remote throttle control is located on the console and allows engine speed to be varied from the operator's seat.

Control valve - 6 spool open centre.

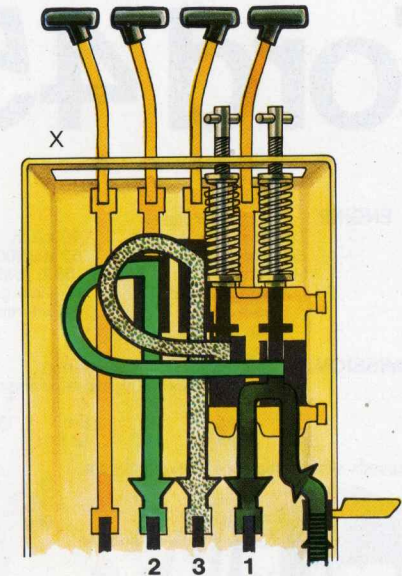

## Performance Data

Maximum digging depth 503 cm (16' 6").

Loading height 315 cm (10' 4").

Reach from swing post 556 cm (18' 3").

Reach from centre line of rear axle 668 cm (21' 11").

Max. Bucket rotation 186°.

Maximum digging force with standard bucket: crowd cylinder 2,808 kg (6,190 lbs); bucket cylinder 3,764 kg (8,300 lbs).

Maximum tearout force at bucket 4,263 kg (9,400 lbs).

Maximum operating pressure - 154 kg/cm<sup>2</sup>

(2,250 lbs p.s.i.).

## Buckets

Buckets are available to suit all trenching requirements in capacities of from 70 litres (2.7 cu ft) to 280 litres (10.2 cu ft).

Other bucket features (Y) include specially designed shape for fast and easy filling and dumping, and replaceable knock-on teeth.

The four-bar bucket linkage allows quick adjustment of bucket rotation and digging power.

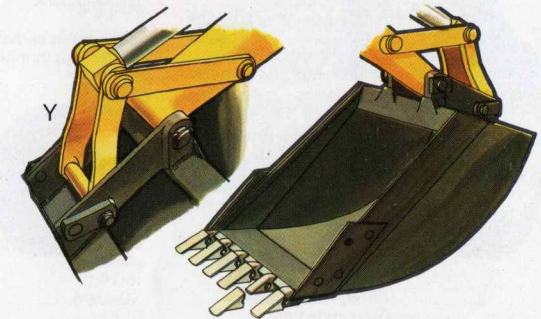

## Cab

The Ford 4550 Centre Pivot safety cab is similar to that on the 4550 Side Shift, packed with the same operator comfort and safety features to make it an ideal day-long working environment.

## Operating Ballast

Specially designed rear wheel weights (Z) provide extra ballast for maximum traction under adverse site conditions.

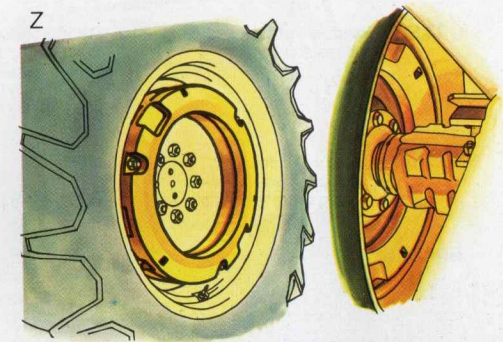

# Ford 4550 specifications.

**ENGINE** Ford 3 cylinder diesel  
 Displacement 201 cu. in.  
 Brake horse power 62 at 2,200 rpm †  
 Max. torque 163 lb. ft. at 1,300 rpm. †  
 Fuel tank capacity 13.3 imp. galls.  
 † Conforms to BS. AU141a

**TRANSMISSION** Standard manual 6 x 4 transmission.  
 Approx. road speeds in mph at rated engine rpm.

Gear	1	2	3	4	5	6
Forward	2-4	4-2	5-7	8-6	15-0	20-5
Reverse	2-8	5-1	10-0	18-1		

Approx. speeds with optional 4 x 4 torque converter.

Gear	1	2	3	4
Forward	3-3	5-3	9-5	21-4
Reverse	3-2	5-3	9-4	21-3

Clutch - single 13" heavy duty, with external greaser (6 x 4 transmission only)

**HYDRAULICS** Pump capacity 22.5 imp. galls./min.  
 System capacity 18.3 imp. galls.  
 System operating pressure  
 - excavator 2250 lb./sq. in. max.  
 - loader 1950 lb./sq. in. max.  
 Control valves - excavator 4 lever  
 - loader 2 lever

**FRONT AXLE** Type Non-adjustable box beam  
 Ground clearance 12.0 in.  
 Track width 56 in.

**REAR AXLE** Type Double reduction inboard planetary  
 Ratio 15.75:1  
 Differential lock Standard  
 Ground clearance 21.4 in.  
 Track width 64 in.

**TYRES** Standard front 7.50 x 16.8 ply Earthmover  
 Optional front 9.00 x 16.10 ply 3 rib  
 9.00 x 16.10 ply 5 rib  
 Standard rear 14.00 x 28.8 ply (R1)  
 Optional rear 14.00 x 28.8 ply Haul Champion

**STEERING** Power assisted Standard  
 Turning circle with brakes 22' 0"  
 Turning circle without brakes 24' 4"

**BRAKES** Wheel brakes Oil immersed disc (4 discs each side)  
 Parking brake Transmission applied

**DIMENSIONS AND WEIGHT**  
 Wheel base 6'7 1/2"  
 Overall width 7'10"  
 Overall length 18'2" (transport position)  
 Overall height 11'5" (excavator in transport position)  
 Operating weight 12,700 lb.

## LOADER

A. Loading height	10'9"
B. Reach - ground level	6'0"
C. - at full height dumped bucket	2'2 1/2"*
D. Lift clearance - dumped bucket	8'7 1/2"
E. Dump angle, max.	37°*
F. Digging depth	4"
G. Roll back - ground level	35°*

	Cyl. Diam.	Rod Diam.
Rams - lift	3"	2"
- bucket	3"	1.5"
Max. front bucket capacity	1 cu. yd.	
Time lift to full height (empty bucket)	4.5 sec.*	
Lower	2.7 sec.*	
Dump	1.7 sec.*	
Lift capacity - full height	4,500 lb.*	
Max. breakout force	7,110 lb.*	

Standard specification includes float position and hydraulic self level device with selector control.  
 \*I.E.M.C. rating

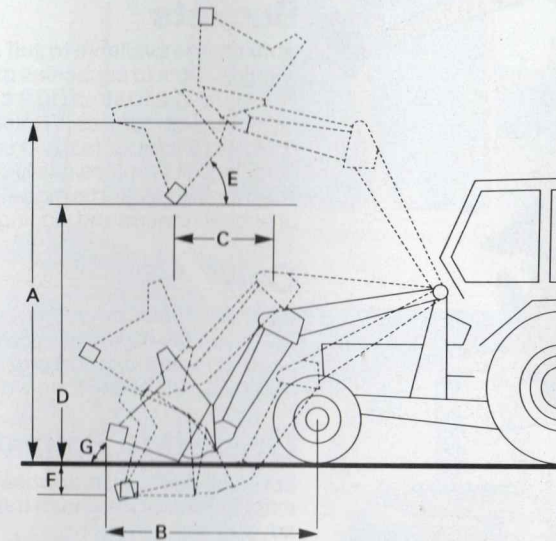

## SAFETY CAB

Ergonomically designed cab meets O.E.C.D. C(70)9 and B.S. 4063 impact and crush test requirements; independently adjustable twin seats; fully weathersealed; powerful heater and demister/defroster; full-size door; front windscreen of laminated safety glass; tool kit; interior light and exterior front rear working lights.

## EXCAVATOR

	<b>Sideshift</b>	<b>Centre Pivot</b>
A. Maximum digging depth at tooth point	13' 6"	16' 6"
B. Loading height	10' 2"	10' 4"
Max. swing arc	182°*	185°*
Swing mechanism	Rotary vane	Chain and hydraulic rams
Rear axle to swing post	4' 3"	3' 8"
C. Reach from swing post	17' 6 1/2"*	18' 3"
Stabiliser spread		
working	-	10' 2"
transport	-	6' 5"
transport and operating with stabiliser pads reversed	7' 10"	-
D. Reach from C/L of rear axle	8' 11 1/2"	-
E. Transport height	21' 3"	21' 11"
F. Bucket rotation	11' 5"	11' 6"
Bucket widths	152"/186"	152"/186"
Bucket capacities	12"-36"	12"-36"
Offset max. from centre	2.7-8.2 cu. ft.	2.7-10.2 cu. ft.
Clamping device	2' 6"	-
	Hydraulic (bolt optional)	-
Control valve	6 spool open centre	
Reservoir	Loader subframes	

	Cyl. diam.	Rod Diam.	Cyl. Diam.	Rod Diam.
Rams - lift	4.0"	2.0"	4.5"	2.0"
crowd	4.0"	2.0"	4.5"	2.25"
bucket	3.5"	2.5"	3.5"	2.5"
stabiliser	3.0"	1.5"	4.0"	1.75"
swing			4.5"	1.75"
Max. digging force (Std. bucket)				
crowd cylinder	5,820 lb.*		6,190 lb.*	
bucket cylinder	8,300 lb.*		8,300 lb.*	
Max. tearout force at bucket	9,400 lb.		9,400 lb.	

Available as an option: Auto-Dig semi-automatic hydraulic digging control.  
 \*I.E.M.C. rating

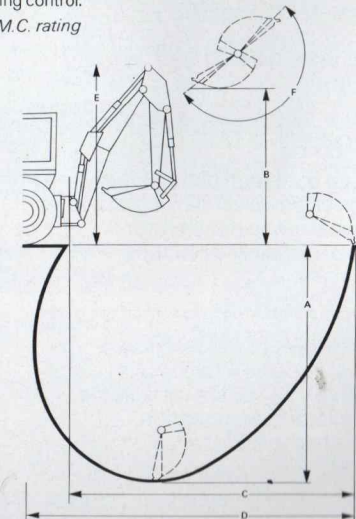

# The Ford range.

The Ford range of Construction Equipment provides a wide choice of models designed and built to take on the toughest construction site operations.

Here we show a selection of Ford models available. Full details and specifications of these and other models in the range may be obtained from your local Ford Construction Equipment Dealer.



# Ford parts and service.

**Parts** When buying replacement parts for Ford construction equipment, look for the distinctive Ford Trade Marks illustrated here. They tell you they're genuine Ford parts and accessories, made to the same high-precision standards as the original factory-fitted components.

Careful attention to stock control at both central and local levels ensures that the items you want are available quickly.

So always insist on the parts that you know will give good service.

Never settle for anything less than genuine Ford products.



**Service** Ford Service isn't just a slogan. It's a reality built up over years of experience in diagnosing, handling and solving the kind of problems you're bound to meet up with on construction work.

Ford-trained service engineers and well equipped workshop facilities are only part of the story. Prompt and personal service is the objective of every Ford Construction Equipment Dealer.

It will pay you to get in touch with your nearest Ford Construction Equipment Dealer. He can supply a reliable machine, backed by fast and effective service.



**Ford Construction Equipment – Built to be relied on**

Ford Motor Company Limited, Tractor Operations, Basildon, England.



Ford policy is one of continuous improvement, and the right to change prices, specifications or equipment at any time without notice is reserved. All data shown in this leaflet are subject to production variations. Dimensions and weights are approximate only. Illustrations do not necessarily show machines in standard conditions. For exact information about any particular machine please consult your Ford Construction Equipment Dealer.