

QUENTIN CURRIE

# FENDT LEADS THE WAY



# Super-Farmer tractors – the No. 1 cho

Outstanding economy combined with high performance and first-class ride comfort are the characteristics of Fendt Super-Farmer tractors. They embody a whole range of crucial advantages which are liable to become increasingly important for the successful farmer of the future.

## Modern energy-saving engines ...

... combine a high power output with remarkably low fuel consumption. The

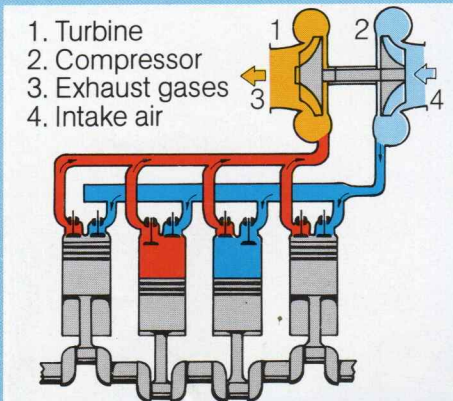

ample cubic capacity guarantees superior traction and long engine life. The Farmer 309 LS (63 kW/86 DIN-HP) is fitted with a four-cylinder turbo-charged engine – the power plant of the future. Unbiased OECD tests show a fuel consumption of only 220 g/kWh (162 g/HPH) at maximum power.

- FARMER 303 LS** 38 kW (52 DIN-HP)
  - FARMER 304 LS** 43 kW (58 DIN-HP)
  - FARMER 305 LS** 46 kW (62 DIN-HP)
  - FARMER 306 LS** 52 kW (70 DIN-HP)
  - FARMER 308 LS** 57 kW (78 DIN-HP)
  - FARMER 309 LS** 63 kW (86 DIN-HP)
- TURBOCHARGED**

## 40 km/h economy operation

With two crucial advantages – either a time saving of up to 30% by travelling at 40 km/h, or a fuel saving of up to 30% with the 40 km/h overdrive engaged, a travelling speed of

25 km/h and reduced engine revs. The speed can be increased from 5.6 to 40 km/h by operating a single

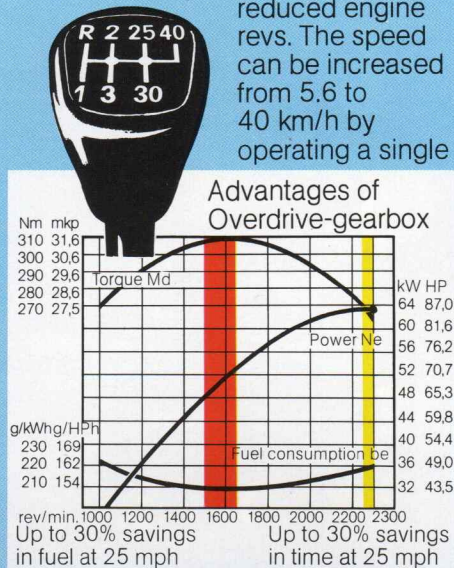

gear lever conveniently located at the right-hand side of the driver's seat.

## Fully synchronmesh, overdrive gearbox with 25 km/h, 30 km/h and 40 km/h speeds

Giving specially high efficiency, as the overdrive shaft "by-passes" the gearbox and power is transmitted via only two pairs of gearwheels. The result – very favourable fuel consumption. A total range of 15 forward gears arranged in highly convenient closely stepped ratios are available for all kinds of PTO, field and road work.

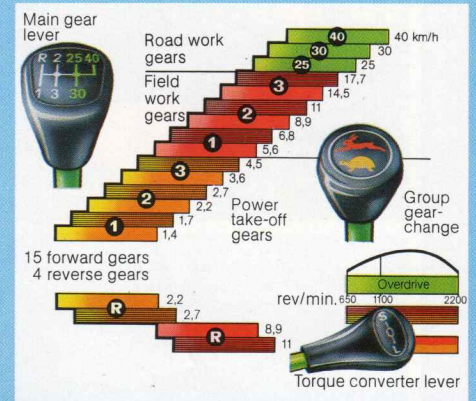

# ice for the successful farmer

Changing from forward to reverse gear is also synchronized.

## Turbomatic

The Turbomatic evens out power surges between the engine and gearbox and results in a quick, smooth getaway without clutch wear. What is more, the smooth driving power supplied via the Turbomatic extends the life of PTO implements and drive shafts.

Moving off smoothly on gradients – thanks to the Fendt Turbomatic!

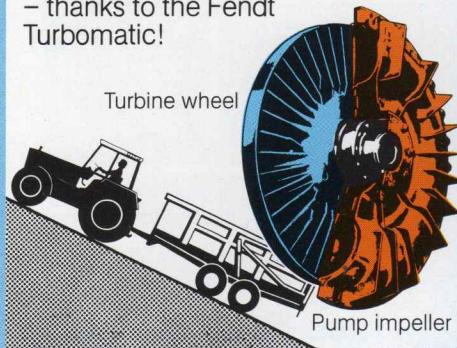

## Full-capacity four-wheel drive with multiple tread contact

The full-capacity, four-wheel drive, the differential locks in the front and rear axles and the wide front and back tyres guarantee that the engine power is transmitted to the ground with hardly any loss. The size of the front tyres (up to 14.9R 24) equals that of tractor types with four identical wheels in this power class. The drive shaft mounted at the side next to the engine ensures

## Automatic Differential Lock

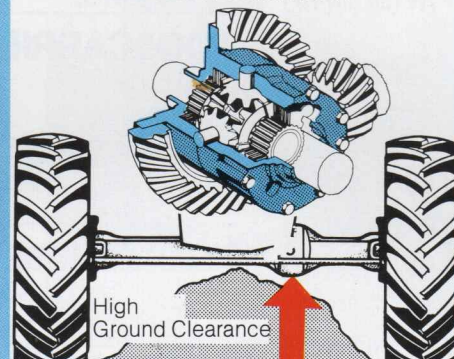

optimum ground clearance, a favourable centre of gravity and high efficiency.

## New towing hitch

Height-adjustable with one hand. No plugs or cotter pins needed.

## New 3-circuit hydraulics

Normal, fast and crawler speed operation. 30% more power in fast operation (higher lifting speed), or up to 15% fuel saving by reducing engine speed, e.g. when using a front loader. Two independent hydraulic pumps.

## Three speed PTO

Super-Farmer tractors have a three-speed PTO fitted as standard (540/750/1000 rev/min). 540 PTO imple-

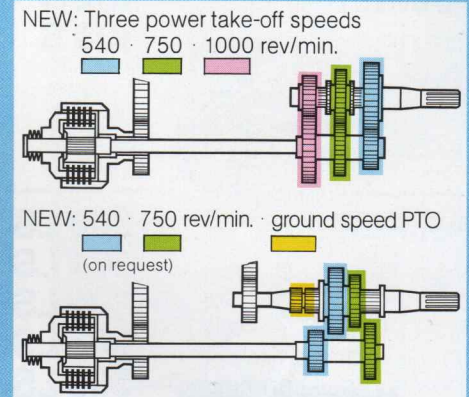

ments can be used with the 750 PTO at  $\frac{2}{3}$  engine speed with a resulting fuel saving of up to 20%. A novelty in agricultural engineering is the 3-speed PTO which is standard super-Farmer tractors. All three speeds can be selected from the driver's seat and are provided by a single PTO stub.

## Easy servicing cuts costs

Self-adjusting clutch – Integral hydraulic brakes – PTO clutch changeable in minutes without dismantling the tractor – Few lubrication points – Air filter and battery easily checked by removing front grille – Tilting cab.



# New: the Farmer 303 LS and 304 LS



Built to the same basic design as the successful four-cylinder Super-Farmers, the new three-cylinder tractors are characterized by their great compactness and outstanding versatility. In technical equipment, economy and ride comfort these vehicles set entirely new standards in

the 3-cylinder class. The front power take-off and front hydraulics mean that mowing and loading can be performed in a single operation.

### **First-class ride comfort**

the cab is supported by rubber bearings and has a wide door for easy

access, gear lever alongside driver, 0.7 m<sup>2</sup> cab platform and a window area of 4 m<sup>2</sup>. There is also a new, body-moulded seat with horizontal spring suspension, a height-adjustable steering wheel and warm water heating. The noise level is very low – only 79 to 83 dB(A) under OECD test conditions.



# Fendt Implement Carriers

Fendt implement carriers are unsurpassed as an efficient means of using farm equipment.

## The high-powered Fendt 255 GT and 275 GT

Many farmers use these implement carriers as the ideal solution where only one tractor is used. On farms employing several tractors, the large implement carriers are used especially for tilling, cultivating and front loader work. The drilling of beet, cereals and



maize and the hoeing of beet, maize and potatoes can be performed in broad strips (up to 6 m wide) with the driver in a comfortable, forward-looking position. Excellent mid-mounting facilities for tilling and cultivating implements ensure work of the very highest quality combined with minimum strain on the driver. The four implement attachment points – rear, middle, front and centre – allow implement combinations which save



both time and fuel. With the 2200 litre spraying system, the implement carrier becomes a true self-propelled vehicle for fighting weeds. The integral, amply dimensioned cab with its 4.7 m<sup>2</sup> window area offers first-class ride comfort and makes a big contribution to relieving the strain on the working driver. Sales of more than 50,000 Fendt implement carriers are solid proof of the success of this system.

## The "universal" Fendt 231 GT



The F 231 GT is the ideal all-purpose machine for the medium-sized and smaller farm. Increasingly, farmers are also opting for the 231 GT as a universally useful No. 2 tractor. As befits a true "maid of all work" its range of application extends from minor haulage jobs using the loading platform with hydraulic tipping control to front loading and mowing duties and to cultivating and tilling using mid-mounted implements and tool combinations.

## The Compact GT – big advantages for mowing and loading

On livestock farms where the mid-mounting facility for implements is not needed, the F 255/275 Compact implement carriers are the ideal all-rounders. The daily harvesting of green forage in a single operation is a job which the Compact implement carrier can perform with the greatest of ease as there is no engine bonnet to obstruct the view of the front-mounted mower. Thanks to the cen-



tral swivel joint – a feature exclusive to the implement carriers – the front-mounted mower is efficiently guided by the front axle. The low centre of gravity confers a high degree of safety when working on slopes. Its great tractive power bordering on that of a four-wheel drive tractor, exceptional versatility and remarkable economy are further potent advantages in favour of the Fendt Compact Implement Carrier. The 1.5 t capacity tippable loading platform is ideal for many minor haulage jobs.



# The winning Fendt range of farm vehicles

## FARMER

**200 S** 28 kW (38 DIN-HP)  
**201 S** 33 kW (45 DIN-HP)

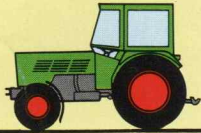

## FARMER

Special-Purpose  
Tractors for Vineyards,  
Hopfields  
and Orchards

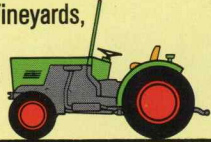

**200 V** 31 kW (42 DIN-HP)  
**203 V** 37 kW (50 DIN-HP)  
**204 V** 48 kW (65 DIN-HP)  
**203 P** 37 kW (50 DIN-HP)  
**204 P** 48 kW (65 DIN-HP)

## FARMER

**102 S** 35 kW (48 DIN-HP)  
**103 S** 41 kW (56 DIN-HP)

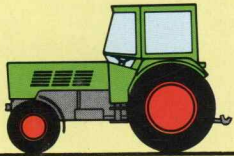

## FARMER

**303 LS** 38 kW (52 DIN-HP)  
**304 LS** 43 kW (58 DIN-HP)  
**305 LS** 46 kW (62 DIN-HP)  
**306 LS** 52 kW (70 DIN-HP)  
**308 LS** 57 kW (78 DIN-HP)  
**309 LS** 63 kW (86 DIN-HP)

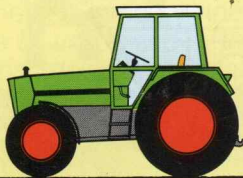

## FAVORIT

**610 LS** 70 kW (95 DIN-HP)  
**611 LS** 77 kW (105 DIN-HP)  
**612 LS** 88 kW (120 DIN-HP)  
**614 LS** 107 kW (145 DIN-HP)  
**615 LS** 121 kW (165 DIN-HP)

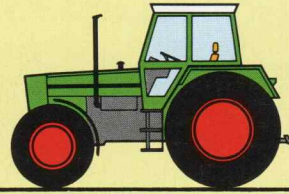

## FAVORIT

**626 LS** 185 kW (252 DIN-HP)



## TOOLCARRIER

**231 GT** 26 kW (35 DIN-HP)

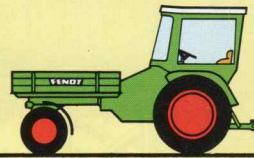

## TOOLCARRIER

**255 GT** 40 kW (55 DIN-HP)  
**275 GT** 51 kW (70 DIN-HP)  
**255 KGT\*** 40 kW (55 DIN-HP)  
**275 KGT\*** 51 kW (70 DIN-HP)

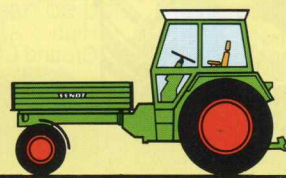

\* = Compact GT

The details of specification, appearance, performance, dimensions, weights, fuel consumption and operating costs of the vehicles were correct at the time of printing. They may not be up to date at the time of vehicle purchase. Your Fendt agent will be glad to inform you of any changes that have taken place.

# FENDT

XAVER FENDT & CO. · 8952 MARKTOBERDORF

