

FORD LOUISVILLE LTL9000

CUMMINS OR CAT POWERED



FORD LOUISVILLE LTL9000.

The LTL9000 is the long-bonneted flagship of the Ford Truck Force and offers a choice of engines up to 331 kW (444 HP). It has been designed for unobstructed service access with a high tilt bonnet and the engine standing clear of the firewall.

EFFICIENCY. IT'S WHAT LOUISVILLE IS ALL ABOUT.

High productivity.

It's made possible by premium quality engineering. Cummins or Caterpillar engines provide the power and performance needed for Line-haul and heavy haulage work. Low downtime is assisted through outstanding accessibility for service and repair.

Cost of ownership.

Through the extensive use of premium equipment and excellent fuel economy combined with design simplicity and fundamental durability, the LTL provides the potential to reduce ownership costs.

Driver environment.

The proven Louisville cab is even roomier with no engine protrusion. Superb seating, comprehensive 'wrap-around' instrumentation and low-effort controls all contribute towards an excellent driver environment.

Driveability.

First-class visibility for a conventional cab design is complemented by an excellent long wheelbase ride, light, precise steering and powerful well-balanced brakes.

12 MONTHS/160,000 KM EXPRESS LOUISVILLE LTL9000 WARRANTY.

(Whichever occurs first.)

The Express Warranty provided by Ford Motor Company of Australia Limited does not deprive a consumer of the rights and remedies which are given to consumers by the Trade Practices Act and applicable State and Territory Laws.

PREMIUM DUTY ENGINES UP TO 331kW (444HP).

The LTL9000 offers a choice of engines from two of the biggest names in the business - Cummins and Caterpillar. They offer today's vital combination of high horsepower and outstanding fuel economy.

CUMMINS N14 SERIES OAC.

This further development of the Big Cam family of 14-litre in-line 6 diesels with Optimised After Cooling provides a choice of three power ratings, plus impressive torque and torque rise figures. An advanced turbocharger and after cooler design ensure high fuel efficiency. The N14 has a large oil pan and engine-mounted by-pass

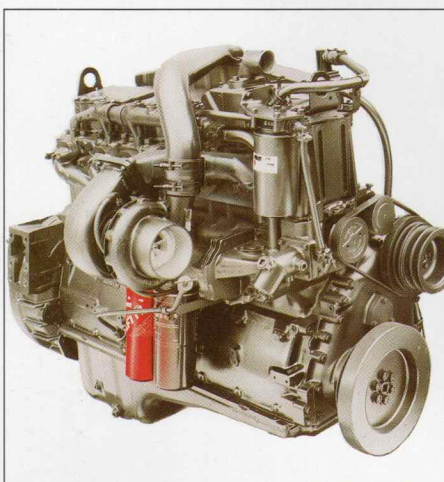

oil filter to assist durability. And it features non-cut-back pistons with a 'quiet' skirt profile. The diesel fuel feed (DFF) injector inhibits carboning helping to reduce maintenance. Step timing control improves performance durability, cold starting and white smoke control.

CATERPILLAR 3406B-ATAAC.

This latest generation Cat engine with Air-to-Air After Cooling also provides operators with the choice of three power ratings. Air-to-Air After Cooling achieves low inlet air temperature, providing more consistent air temperature control over the engine operating range for efficient combustion, excellent fuel economy and engine response with less emissions.

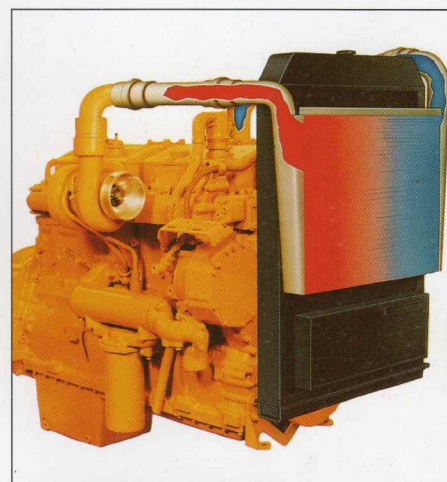

ENGINE PERFORMANCE SPECIFICATIONS:

Engine	Nominal Gross kW (HP) @ governed RPM	Gross peak torque Nm (1lb. ft.) @ RPM	Torque Rise
Cummins N14NTC-365	272 (365) @ 2100	1797 (1325) @ 1300	44%
Cummins N14NTC-400	298 (400) @ 2100	1797 (1325) @ 1300	32%
Cummins N14NTC-444	331 (444) @ 2100	1898 (1400) @ 1500	26%
Caterpillar-ATAAC 3406B 350	261 (350) @ 2100	1789 (1320) @ 1100	51%
Caterpillar-ATAAC 3406B 425	317 (425) @ 2100	1966 (1450) @ 1200	36%

BACK-UP POWER.

Back-up power describes the engine's ability to produce maximum horsepower at 200-400 RPM below governed engine speed. Both the Cat 350 and Cummins 365 engines exhibit excellent back-up power characteristics.

This feature, combined with exceptional torque rise, contributes

to economical operation by reducing the need to downshift on grades. It encourages drivers to operate a lower engine RPM and achieve reduced running costs.

BACK-UP POWER

CAT 350 ATAAC
273kW (366 HP) @ 1800 RPM

Cummins 365 N14
280kW (375 HP) @ 1800 RPM

CAB-DESIGN CONCEPT.

The full conventional or long bonneted cab configuration of the LTL9000 offers a number of important benefits.

- Ease of service access and repair.
- Ability to undertake major service overhauls 'in frame'.
- Permits vertical engine installation without any protrusion into the cab.
- Provides a full cab walk-through facility.
- Aerodynamically efficient, with a sharp angle of attack to help reduce air drag and assist fuel efficiency.
- Aerodynamic deep-section bumper design for an air dam effect.
- Design simplicity of fixed cab.
- Improved driver position with 'distance' between the driver and front bumper.
- Tilting front end provides complete 'feet-on-the-ground' servicing.
- Body panels designed for fast, easy repair.

All-welded steel cab construction.

The cab is ruggedly reinforced with steel underbody members. Door frames are unit-welded and of box section construction. All major panels are galvanised for corrosion protection.

Fibreglass bonnet/front end.

Bonnet and fenders of the LTL9000 are styled in tough, resilient weight-saving fibreglass. Features are:

- High technology, compression-moulded design with controlled gauge and thickness and repeatable surface finish.
- Lightweight aluminium forging hinge design with adjustment fore and aft and vertically for an excellent fit.



- Gas-struts to assist opening.
- Integral intake plenum, side intakes with screens achieve low pressure loss with good water separation.
- Under-hood air cleaner location means a clean exterior shape and reduced air drag. It also protects the air cleaner from the elements and accidental damage.
- Integral hand-hold to tilt bonnet is out of sight on top of grille return.
- Stabiliser system to help stop movement between hood and cab, plus guide to assure smooth closure.
- Rigid two-piece shell design fenders integral with bonnet.
- Combination dual quartz halogen headlight and driving light assemblies mounted in guards.



- Easily repairable fibreglass. The bonnet front carries the distinctive LTL9000 radiator grille fabricated from anodised aluminium extrusions to produce a bright, rigid assembly.

DRIVER COMFORT AND CONVENIENCE.

Easy entry and exit.

- Wide opening 70° doorways.
- Two conveniently located cab steps.
- Outside assist handle.



Seating-basis for driver comfort.

The Bostrum contoured bucket seat is air suspended, air adjustable.

Custom level equipment.

- Comprehensive instrumentation includes electronic speedometer, electronic tachometer, plus gauges for air pressure, engine oil pressure, water and oil temperature, transmission and rear axle oil temperature, voltmeter, pyrometer, air restriction and fuel level.
- Warning light module includes lights for low brake pressure, water temperature, oil pressure, coolant level, inter-axle lock, engine and transmission oil temperature.

- Driver-oriented wrap-around instrument panel and padded fascia.
- Air-Pac control panel with different shaped levers for easy driver identification without looking away from the road.
- Heater controls are the slide type for precise setting and easy adjustment.
- Three-speed fan for heating and demisting.
- West Coast rear view exterior mirrors.

Driving and Visibility.

The LTL9000 has an adjustable steering column and a constant 20° wheel angle for driver comfort. Instruments are grouped for easy readability. Controls are easy to reach. The large windscreen area of 9770cm² (1515sq.in.), no centre pillar and the absence of a stack-mounted air cleaner all contribute to excellent driver visibility. Intermittent wipers sweep nearly 80% of the windscreen area.

LOW OWNERSHIP COST.

The LTL9000 is designed for economical ownership and operation.

- Extensive use is made of premium 'industry standard' equipment.
- Most major components are fully rebuildable.
- The Cummins-Caterpillar engine line-up offers excellent fuel efficiency.
- With basic design simplicity and outstanding durability.

Ease of maintenance and service.

- Radiator low level warning light.
- Air cleaner restriction gauge.
- Feet-on-the-ground maintenance with bonnet tilted to 60°, or easily removed for major overhaul.
- Colour-coded air hoses ensure fast service tracing.
- Removable Air-Pac allows controls and manifold to be serviced in place or on the bench.

Electrical system.

A system of multi-pin plugs and colour-coding speeds circuit tracing and the rectification of any faults.

- Fuse panel located behind a drop-down door on the left of the instrument panel.
- Relays ensure maximum possible circuit efficiency.
- A cabin-mounted isolator switch allows the cabin electrical supply to be switched off from inside the vehicle.
- Provision of additional and labelled wiring circuits for added accessories - e.g. driving lights, air-conditioning, radio(s), additional clearance lamps, overhead console, sleeper box.
- AVX high temperature-resistant wiring under bonnet.
- Waterproof connectors to all external wiring.

Battery location and features.

- 4x6 volt 158 AH batteries are located in battery boxes tucked forward of the fuel tanks on both sides, behind the fender splash shield for protection from the elements.
- Boxes are frame-mounted close in to reduce potential battery damage from vibration.
- Battery cables have been kept short for low voltage drop.
- Batteries are easily accessible.

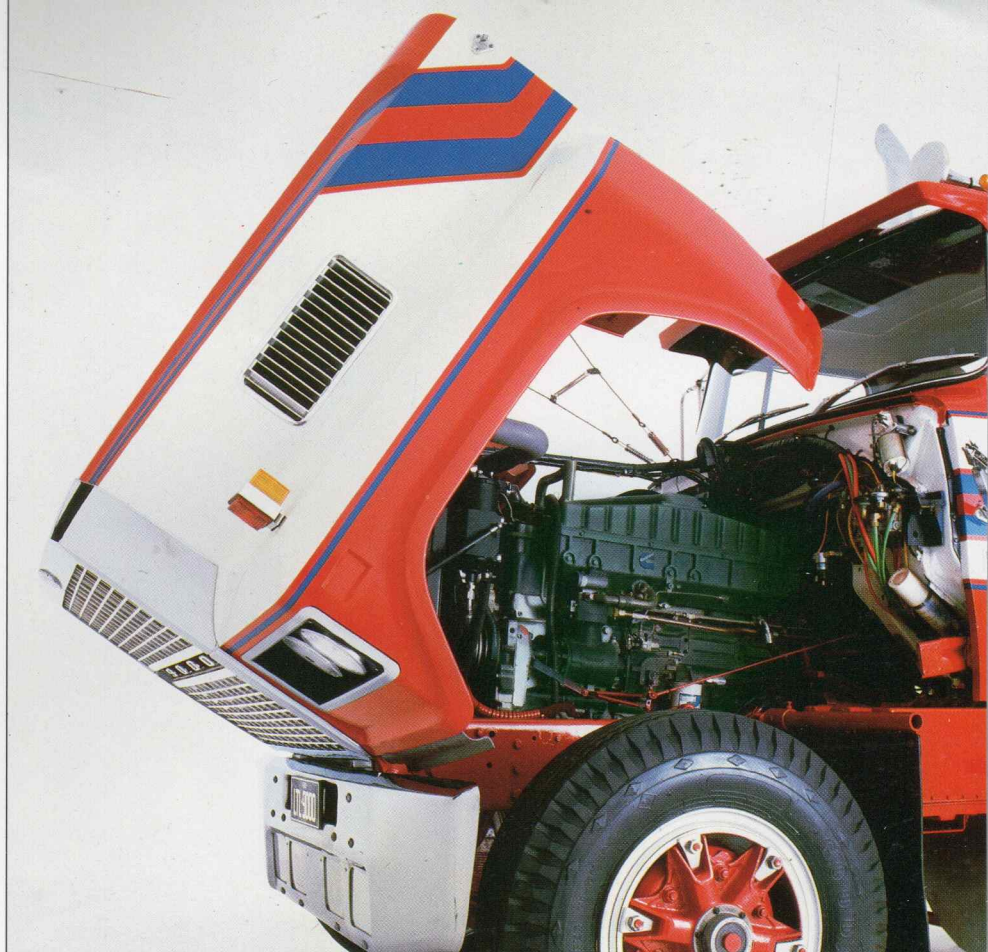

Engine cooling system.

- The LTL9000 is fitted with a heavy duty 9323m² (1445sq.in.) frontal area cross-flow radiator.
- The cross-flow design reduces radiator height and allows a lower bonnet line for good driver visibility.
- A fan clutch offers the potential to reduce fuel consumption.
- A coolant de-aeration system purges trapped air at engine start-up, helping to eliminate hot-spots.
- Reinforced silicone hoses for durability and long life.

Underhood engine air cleaner.

A cowl-mounted dry-type Donaldson Cyclopac 406 mm (16") 2-stage air cleaner with safety element, restriction indicator gauge and an automatic vacuator valve are fitted. The air cleaner is easily serviced in its protected under-bonnet location.

Exhaust system.

The single vertical muffler and pipe has been constructed for design simplicity. It is frame-mounted for improved durability and stands free of the cab corner so reducing the effects of engine noise and vibration on the driver.

Louisville parts identification programme.

A Truck Specification List (TSL) for every Louisville manufactured lists over 40 major components. Copies are fitted in the cab of the truck, retained by the selling dealer and held in the Ford National Parts Depot in Melbourne. In this way, replacement orders can be checked against the TSL, ensuring the supply of the correct part and often saving valuable time.

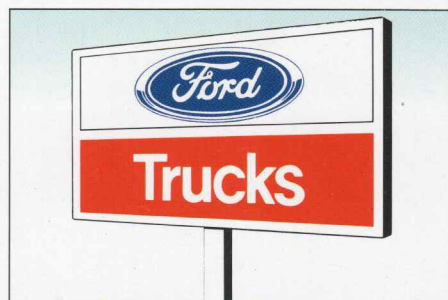

Ford Heavy Truck Service and Contract Maintenance Program.

This Program is designed to assist fleets with their forecasting and budgeting by offering a maintenance contract tailor-made to their requirements to cover specified scheduled servicing, mechanical repairs and breakdowns on new Ford trucks throughout their long working life.

THE LTL9000.

Taking efficiency to new lengths with rugged 'American' drivetrain components. Proven durability. Easy to service. Widespread availability of replacement parts.

FULLER ROADRANGER TRANSMISSION.

The LTL9000 is fitted with the direct drive RTF 14615 transmission with oil cooler.

Fuller multi-mesh gearing delivers quiet performance because two or three teeth per gear are always in contact.

SPICER CLUTCH AND DRIVELINE.

A Spicer two-plate ceramic disc clutch is fitted. It features manual adjustment and sealed release bearings. Spicer 1800 Series drive and Spicer 1700 Series, inter-axle shafts are fitted.

ROCKWELL REAR AXLES.

The LTL9000 has the Rockwell SP-40G tandem axle fitted as standard normal duty. The SSHD tandem axles are offered as an extra cost option for heavy duty applications. While the Rockwell ST170 or Eaton DT489P are available on extra heavy duty models. These tandem axles are proven Australia-wide.

REAR SUSPENSIONS.

The Hendrickson RT-380 medium duty suspension is fitted as standard. Optional suspensions include the smooth riding Hendrickson E4-380 and the heavy duty Rockwell 6-Rod, available at extra cost. The Rockwell Heavy Duty AC6T 6-Rod suspension is standard on extra heavy-duty models.

FRONT SUSPENSIONS.

All models feature multi-leaf, asymmetric design front springs.

STRONG, HIGH TENSILE STEEL CHASSIS.

'Application designed' on an energy-absorbing principle. Single channel rails are of premium high tensile steel with a yield strength rating of 758,000kPa (110,000psi). Extra heavy duty models have double section rails for increased strength and stability. Cross-members are high-strength steel stampings

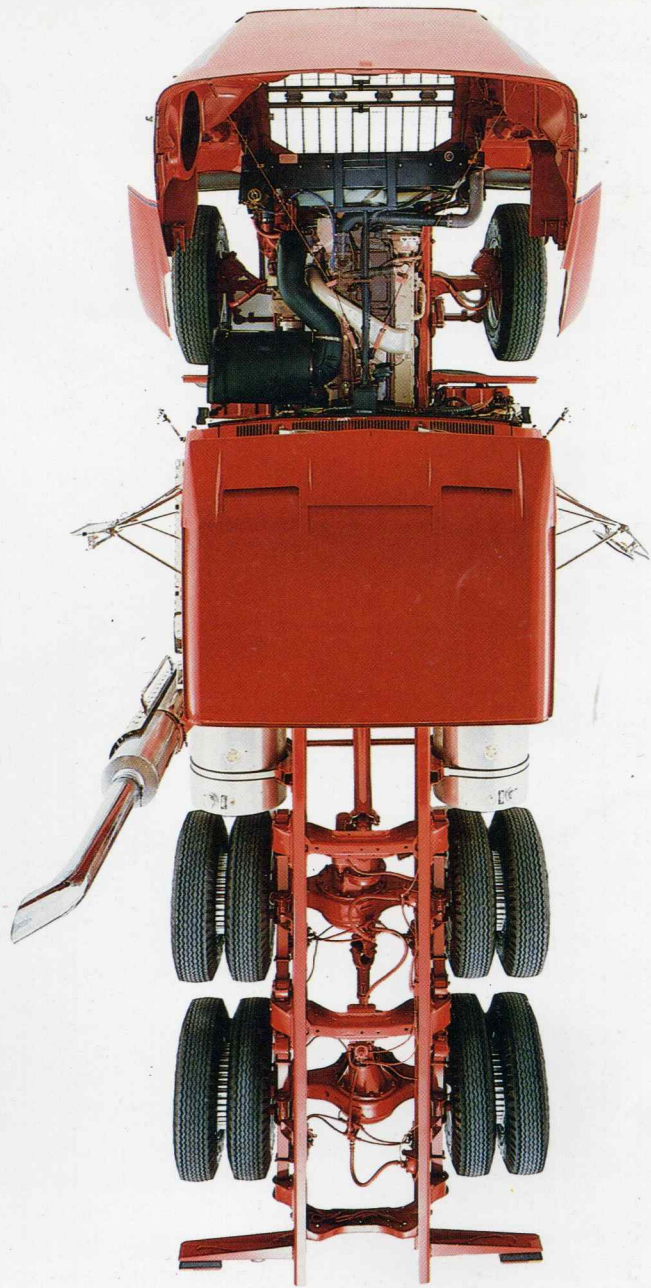

bolted to the rails with grade 8 bolts and prevailing torque nuts. Features include a clean, flat-top design with all cable, air and fuel lines running inside the frame.

HANDLING AND MANOEUVRABILITY.

Recirculating ball power steering for light, precise control and excellent manoeuvrability.

LTL9000 BRAKING SYSTEMS.

They combine exceptional power with fast response and outstanding stability under harsh working conditions.

- Dual line full air system.
- Three-reservoir, wet-tank system.
- Colour-coded air brake lines for easy tracing.
- Lines are extremely resistant to abrasion, remain pliable under

temperature extremes, resist aging and remain inert in water.

- Fittings are reusable.
- Spring-set park brake operates on both rear axles.
- In the event of rear service brake loss, the spring-set is operated via the foot pedal giving a modulated application.
- Engine brake. Standard fitting on LTL9000. Converts a power-producing engine into a power-absorbing compressor.
- Fuel tanks. Dual cylindrical aluminium fuel tanks with a combined capacity of 726 litres are the standard fitting. An extra two cylindrical tanks are available as an extra cost option. The quad tank arrangement provides a total capacity of 1452 litres.

LOUISVILLE LTL9000 - CONDENSED SPECIFICATIONS.

MODEL LINE-UP

	Mass Loads (kg)		Engine		Trans.	Rear Axle	Rear Suspension		
	GVM	CGM	CUMMINGS NTCN14	CATERPILLAR 3406B	FULLER	ROCKWELL	HENDRICKSON 2-SPRING	ROCKWELL 4-SPRING	
NORMAL DUTY	23240	45000	365	350	RTF14615	SP-40G	RT-380	E4-380	-
HEAVY DUTY	23240	81000	365	350	RTF14615	SSHD	RT-380	-	-
EXTRA HEAVY DUTY	26000*	90000	400/444	425	RTF14615	SSHD	-	-	6-ROD
EXTRA HEAVY DUTY	26000	120000	444	425	RTF14615	ST170 (Eaton DT489P)	-	-	6-ROD

Note: Cummins and Caterpillar 300 HP performance and fuel economy versions available on application.
 9- and 13-speed Fuller transmissions available on application.
 *26000kg rating available with SSHD and 6-Rod.

Dimensional Data

WB (mm)	CA (mm)	AF (mm)	OAL (mm)
5182	2959	1905	7811

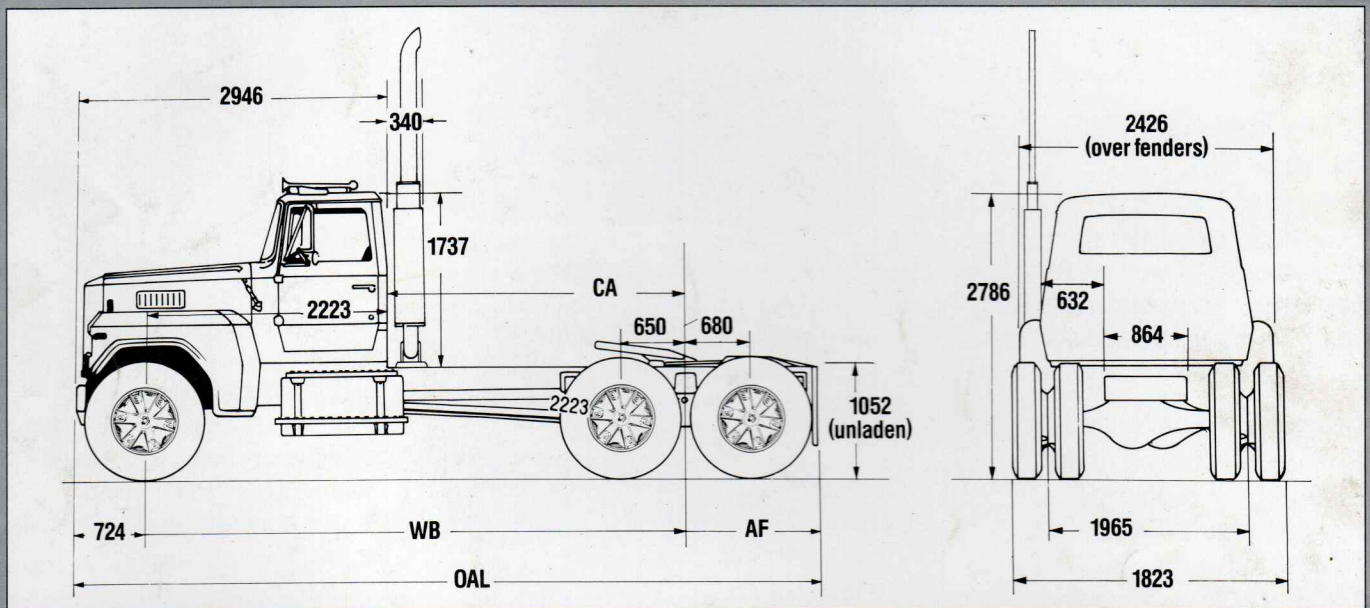

About this brochure. This brochure is designed to provide you with a general introduction to the Ford Products (including available optional equipment) referred to, and should be read in conjunction with the latest specification sheets. Because of changes in conditions and circumstances Ford* reserves the right, subject to all applicable laws, at any time, at its discretion, and without notice to discontinue or change the features, designs, materials, colours and other specifications and the prices of its products, and to either permanently or temporarily withdraw any such products from the market without incurring any liability to any prospective purchaser or purchaser.

The latest specification sheet should be referred to for information on the availability, ordering and use of optional equipment. Always consult an Authorised Ford Dealer for the latest information with respect to features, specifications, prices, optional equipment and availability before deciding to place an order.

*FORD MOTOR COMPANY OF AUSTRALIA LIMITED.
 (Incorporated in Victoria)
 Registered Office: 1735 Sydney Road,
 Campbellfield, Victoria 3061,

PRINTED JANUARY 1988



Ford Trucks - an investment in value.