

MX SERIES 180-270 HP



CASE IH

SPECIFICATIONS

MX SERIES SPECIFICATIONS

	MX180	MX200	MX220	MX240	MX270
ENGINE					
Model Range	Case Family II	Case Family II	Case Family II	Case Family II	Case Family II
Cylinders/capacity/aspiration	6TA-AC	6TA-AA	6TA-AA	6TA-AA	6TA-AA
Maximum Engine Power (kW/HP)	152/204	164/220	181/243	202/271	228/306
Rated Power @ 2000RPM (kW/HP)	134.3/180	149.2/200	164.1/220	179.0/240	201.4/270
Constant power range RPM	1450-2000	1450-2000	1450-2000	1450-2000	1450-2000
Bore x Stroke (mm)	114 x 135	114 x 135	114 x 135	114 x 135	114 x 135
Maximum Torque (nm) @ 1400rpm	865	1000	1110	1240	1400
Torque Rise (%) (PTO)	40	46	46	46	46
Cylinder Sleeve Type	Wet-Mid Stop	Wet-Mid Stop	Wet-Mid Stop	Wet-Mid Stop	Wet-Mid Stop
TRANSMISSION					
Type			FULL POWER SHIFT		
Number of speeds	18fwd/4rev	18fwd/4rev	18fwd/4rev	18fwd/4rev	18fwd/4rev
Number of speeds with creeper (Standard in NZ)	24fwd/6rev	24fwd/6rev	24fwd/6rev	24fwd/6rev	24fwd/6rev
Axle length/diameter (mm)	2995/102	3050/102	3050/102	3050/114	3050/114
MFD FRONT AXLE					
Differential	LSD	LSD	LSD	LSD	LSD
Steering Angle	55°	55°	55°	55°	55°
Caster / Oscillation Angles	0.5°/11°	0.5°/11°	0.5°/11°	0.5°/11°	0.5°/11°
4 Wheel Braking	Standard	Standard	Standard	Standard	Standard
Optimum turning radius without brakes (m)	4.85	4.85	4.85	4.85	4.85
POWER TAKE OFF					
Number of Shafts (Standard/Optional)	2	2	2/3	1/2	1/2
PTO Speeds	540/1000	540/1000	540/1000	1000	1000
Engine Speed @ 540 rpm	2000	2000	2000	NA	NA
Engine Speed @ 1000 rpm	2000	2000	2000	2000	2000
HYDRAULIC SYSTEM					
Total pump capacities (L/min / GPM-US)	280/71	280/71	280/71	280/71	280/71
Max Flow @ Remotes (L/min/GPM)	170/44	170/44	170/44	170/44	170/44
No remotes Std/Opt	4/5	4/5	4/5	4/5	4/5
Lift capacity at 610mm through range (kg/lbs)	5,100/11,200	6,600/14,500	6,600/14,500	7,260/16,000	7,260/16,000
Remote hitch switch	Standard	Standard	Standard	Standard	Standard

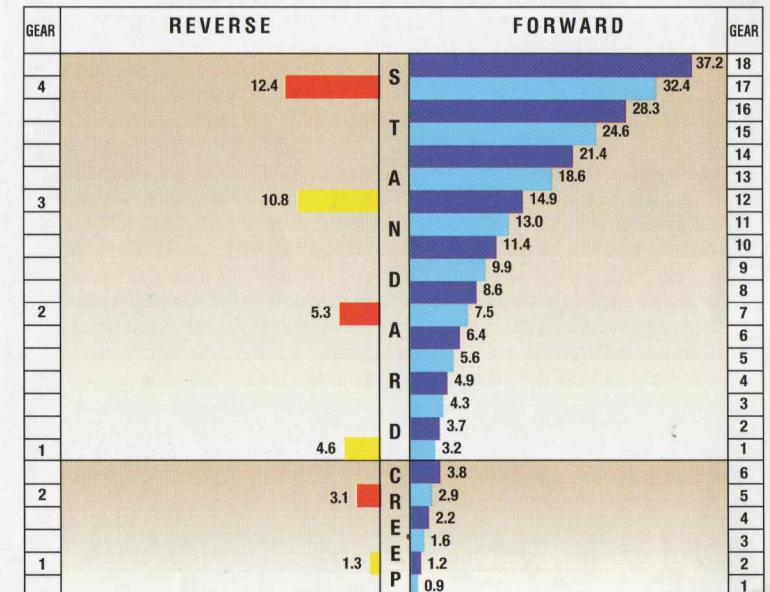

MX SERIES FEATURES

The MX Magnum tractor brings with it another advance in technology in farm tractor design. These advances are not only intended to meet the needs of today's production farmer, they are ready for the most demanding technological requirements of the future.

The Deluxe Air conditioned "Surveyors" cab has a spacious, ergonomically designed interior for maximum operator comfort and control. With noise levels down to 72 dBA the new Magnum cab with luxury interior creates the ideal environment for long hours of operation in the field.

The new cab provides unprecedented visibility for enhanced operator productivity.

Designed to give the ultimate in ride and comfort, the fully adjustable, contoured, suspension seat provides plenty of lateral support, even on rough terrain. (Note: The training seat shown is not available).

External hitch controls, easy to use hydraulic couplers make hook up of even the largest implement easy.

Electronic transmission control gives you even greater flexibility in the field. With the addition of a power shuttle shift the new MX Magnums are ready for any application.

The proven "Exclusive" master clutch design used in all Magnum tractors is retained in our new units. With true 40kmph, 18 forward and 4 reverse speeds (24F/6R with optional creeper) you have the working speeds for any job.

A new heavy duty rear axle with a 114mm diameter is standard on the MX240 and 270.



A new high flow PFC hydraulic systems delivers a massive 170 litres per minute (45GPM) at the couplers for the most demanding of hydraulic tasks increasing productivity and reducing operating costs.

A new ergonomically designed arm rest puts your controls at your fingertips. Engine, transmission and hydraulic controls are easy to operate and arranged logically for improved operator productivity.

A new performance monitor not only measures the area covered but also records distance and fuel usage per hour.

All units come with 12 working lights, front and rear washers and wipers, rear view mirrors and tool box.

To keep you in the field longer we have a 500 litre fuel tank on MX180-220 and a massive 602 litres on the MX240 and MX270.

MX Magnums feature the proven 8.3 litre Case Family II Encore Engines for proven torque, power and reliability. Full Authority Electronic control on the MX240 and MX270 ensures new levels of engine performance with up to 36hp power growth.

New tyre and ballasting options are available on all models including the ability to fit a 520/85R46 (20.8R46) tyre to all models.

A new heavy duty MFD axle gives you not only outstanding reliability but the option to fit front duals to the MX240 and MX270.

Extended service intervals, tilt hood and simple one point daily service door makes the new Magnum even easier to service.

MX SERIES SPECIFICATIONS

	MX180	MX200	MX220	MX240	MX270
CAPACITIES					
Fuel Tank (Litre)	500	500	500	602	602
Engine Oil (Litre)	21	21	21	21	21
Cooling System (Litre)	22.7	22.7	22.7	24.6	24.6
Transmission / Hydraulic MFD (Litre)	172	172	172	172	172
SERVICE INTERVALS					
Engine Oil / Filter Change (Hours)	300	300	300	300	300
Engine Fuel Filter Change (Hours)	600	600	600	600	600
Transmission Hydraulic Oil Change (Hours)	1500	1500	1500	1500	1500
WEIGHT					
Base Shipping Weight	8210	8440	8440	8530	8530
Maximum Permissible Weight (Kg)	9530	10660	12020	13380	14290
DIMENSIONS					
A. Wheelbase (mm)	3005	3005	3005	3005	3005
B: Length, rear hitch arms – weight frame (mm)	5680	5680	5680	5740	5740
C. Height to top of cab (mm)	3122	3122	3165	3165	3165
D. Ground clearance (mm)	467	467	410	410	410
Measurements on wheel equipment	480/80R42	480/80R42	480/80R42	480/80R42	480/80R42
Minimum wheel track on 480/80R42(mm)	1524	1524	1524	1524	1524
SURVEYORS OPERATORS ENVIRONMENT					
Front and rear windscreen wiper/washers	Standard	Standard	Standard	Standard	Standard
Performance monitor	Standard	Standard	Standard	Standard	Standard
Air suspension seat	Standard	Standard	Standard	Standard	Standard
WHEEL EQUIPMENT					
Note - Refer to your Case IH Dealer					

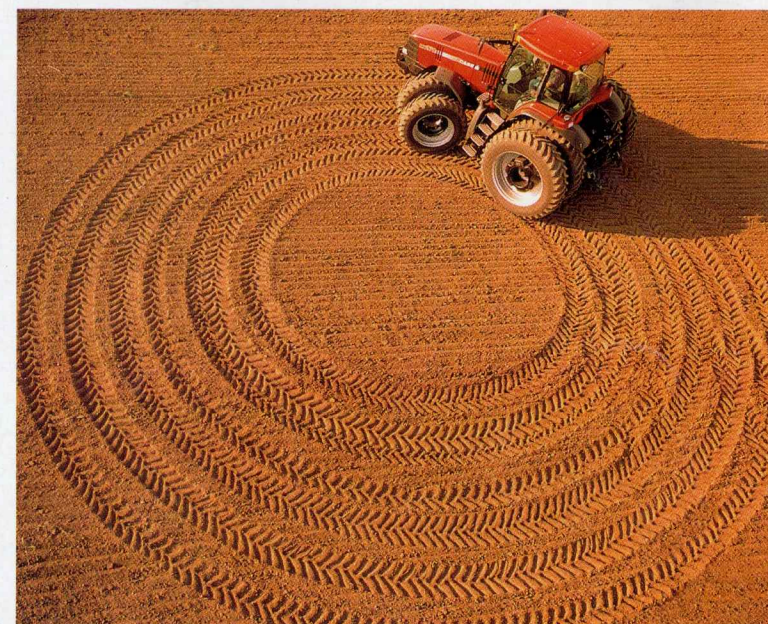
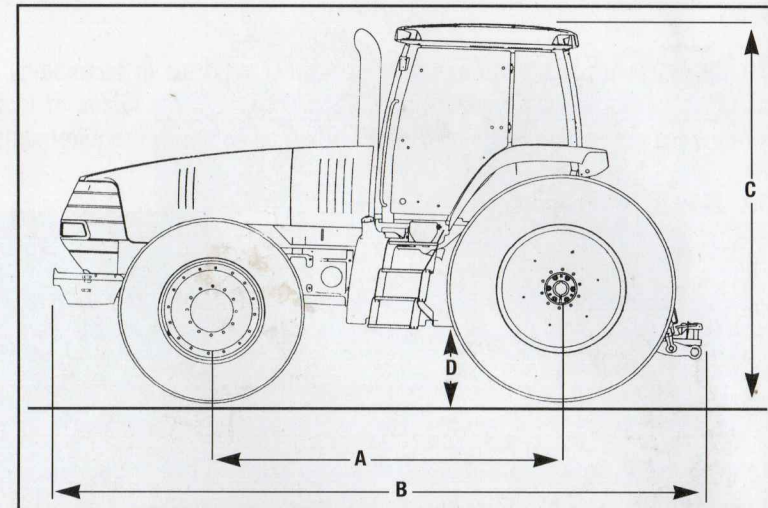

CASE IH

www.casecorp.com

Important: The Case Corporation reserves the right to make improvements in design and changes in specifications at any time without notice and without incurring obligation to install them to units previously sold.

Attention Readers: Local availability, standard specification and options may vary from those listed in this publication.

Your local dealer will gladly advise concerning availability and recommended specifications.

Form No. PMA MXMG 6/99

CASE CORPORATION PTY LTD
ACN: 000 031 130
31-67 KURRAJONG AVENUE
ST MARYS NSW 2760
TELEPHONE: (02) 9673 7777

NEW ZEALAND OPERATIONS
PO BOX 22872
13A WEKA STREET
OTAHUHU, AUCKLAND
NEW ZEALAND
TELEPHONE: (09) 270 0250

Certified to ISO Standard for operating a Quality System