

# FORD D500 TRUCK - PETROL & DIESEL

*July 1971*

## RATINGS

Maximum G.V.W. .. .. . 18,000 lb.  
 Maximum G.T.W. .. .. . Petrol 19,000 lb.  
 .. .. . Diesel 28,000 lb.

*P 5,181*  
*D 5,933*



## SPECIFICATIONS

**PETROL ENGINE** .. .. . Ford 240 Six Cyl.  
 Displacement.. .. . 240 cu. in. (3928 c.c.)  
 Compression Ratio .. .. . 7.1 to 1  
 Gross Brake Horse Power .. .. . 129 at 3500 r.p.m.  
 Net Brake Horse Power .. .. . 105 at 3500 r.p.m.  
 Gross Torque.. .. . 208 lb. ft. at 2100 r.p.m.  
 Net Torque .. .. . 183 lb. ft. at 2400 r.p.m.

**DIESEL ENGINE** .. .. . Ford 365 Six Diesel  
 Displacement .. .. . 363 cu. in. (5948 c.c.)  
 Compression Ratio .. .. . 16.5 to 1  
 Gross Brake Horse Power .. .. . 115 at 2800 r.p.m.  
 Net Brake Horse Power .. .. . 103 at 2800 r.p.m.  
 Gross Torque.. .. . 247.5 lb. ft. at 1600 r.p.m.  
 Net Torque .. .. . 234.5 lb. ft. at 1500 r.p.m.

**ENGINE EQUIPMENT**  
 Air Cleaner - Petrol.. .. . Oil Bath Type  
 - Diesel .. Dry Type with Stack Pipe  
 Crankcase Ventilation.. .. . Positive Air Flow  
 Oil Filter .. .. Full Flow Replaceable Element

**CLUTCH** .. .. . Single Dry Plate  
 Facing Area .. .. . Petrol - 12 in. 160 sq. in.  
 .. .. . Diesel - 12 in. 138 sq. in.

**GEARBOX** .. .. . Ford T98A 4-Speed Direct  
 Ratios .. .. . 6.325, 3.092, 1.686, 1.000  
 .. .. . Reverse 7.440 to 1

**AXLE, REAR** .. .. .  
 Type .. .. Ford 14B Hypoid Single Speed  
 Capacity.. .. . 15,000 lb.  
 Ratio .. .. . Petrol - 6.17 : 1  
 .. .. . Diesel - 5.29 : 1

**FRAME** .. .. . Ladder Construction  
 Width .. .. . 34 in.  
 Sidemember Section .. .. . Single Channel  
 Sidemember Dimensions .. 9.5 x 2.97 x 0.21 in.  
 Section Modulus .. .. . 8.43 cu. in.  
 Yield Strength .. .. . 34,500 lb./sq. in.

**AXLE, FRONT** .. .. . Ford Rigid I Beam  
 Capacity.. .. . 7500 lb.

**SPRINGS, FRONT** .. 6 Leaf 3350lb. capacity at Pad

**SPRINGS, REAR** .. 10 Leaf 5700lb. capacity at Pad

**SHOCK ABSORBERS** .. .. . Front

**WHEELS**.. .. . Disc Type 6 Stud, three piece  
 Size of Rim .. .. . 16 x 6.5H  
 1 - Spare Wheel and Cradle Type Carrier mounted under Frame.

**TYRES** .. .. . Tube Type  
 Front and Rear .. .. . 8.25 x 16, 12 Ply

**BRAKES, SERVICE** .. .. . Girling Hydraulic  
 Front .. .. . 13 x 4 in. 2 Leading Shoe  
 Rear .. .. . 13 x 5 in. 2 Leading Shoe

**BRAKES, PARKING**  
 Mechanical - Operating the Rear Service Brakes by Rod and cable.

**BRAKE EQUIPMENT, PETROL ENGINE**  
 Vacuum Booster .. .. . 9.50 in dia. Hydrovac

**BRAKE EQUIPMENT, DIESEL ENGINE**  
 Air/Hydraulic Booster Clayton Dewandre "Air Pak"

**STEERING GEAR**.. .. . Cam 300Q Worm and Peg

**ELECTRICAL SYSTEM** .. 12 volt, Negative Earth  
 Battery .. .. Diesel-120 amp. hr. at 20 hr. rate  
 .. .. . Petrol-57 amp. hr. at 20 hr. rate  
 Alternator .. .. . 38 amp.  
 Starter Motor Petrol .. .. . Plunger Pole Type  
 Starter Motor Diesel .. .. . Lucas M50 Pre-engaged  
 Headlamps .. .. . Semi-Sealed Beam 50/40W

**FUEL SYSTEM, PETROL**  
 Carburettor .. .. . Ford Single Venturi  
 Fuel Tank .. .. . Circular, Frame Mounted  
 Capacity .. .. . 20 Imp. Galls.  
 Fuel Filter .. .. . Cartridge Type

**FUEL SYSTEM, DIESEL** .. .. . Direct Injection  
 Injection Pump .. .. . Simms Minimec  
 Lift Pump .. .. . Mechanical Type  
 Fuel Tank .. .. . Rectangular, Frame Mounted  
 Capacity.. .. . 20 Imp. Galls  
 Fuel Filter .. .. . Two Stage Type  
 Water Separator .. .. . Replaceable Element Type

**COOLING SYSTEM** .. Pressurised, Pump Assisted  
 Radiator .. .. . 2 Core  
 Fan Shroud

# DIMENSIONS AND WEIGHTS D500

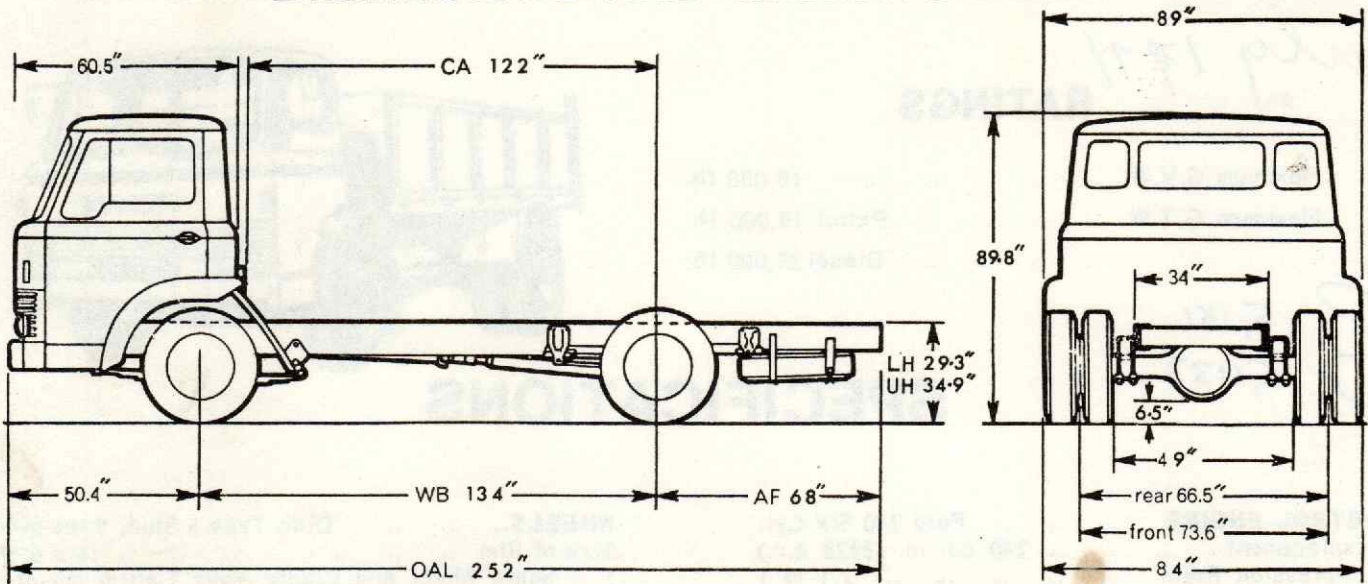

## CALCULATED KERB WEIGHTS

PETROL		DIESEL		
Front	.. ..	..3510lb.	Front .. ..	..3970lb.
Rear	.. ..	..1860lb.	Rear .. ..	..1860lb.
Total	.. ..	..5370lb.	Total .. ..	..5830lb.

## CAB SPECIFICATIONS

**CAB..** .. .. Tilt Assisted  
**Finish** .. .. Acrylic Baked Enamel

### CAB EQUIPMENT

- Direction Indicators
- Door Lock (Driver's Side)
- Interior Light
- Toughened Glass Windshield with Zoned area
- Driver's Seat – adjustable for height, reach and rake
- Dual Passenger Seat
- Headlining
- Opening Quarter Vent Windows
- Glove Compartment
- Speedometer
- Vacuum or air pressure Gauge
- Odometer
- Battery Condition Meter
- Oil Pressure Gauge
- Fuel and Water Temperature Gauges
- Electric Windshield Wipers
- 6 in. Deep Front Bumper
- Two Towing Eyes – mounted on reinforced bumper

- Printed Circuit Instrument Cluster
- Exterior Rear View Mirrors
- Large Ash Tray
- Rubber Floor Mats retained by Aluminium Scuff Plates
- Fused Lighting Circuit
- Sun Visor – Interior, Driver's Side
- Front Fender Mudflaps
- Dual Electric Horns
- Safety Belt Anchorages
- Audible Brake Warning Device (Air/Hydraulic Only)

### Warning Lights:–

- High Beam
- Alternator
- Turn Indicator
- Oil Pressure

### Tools:–

- Jack and Handle
- Wheel Nut Wrench

Ford policy is one of continuous improvement. The right to change prices, specifications or equipment at any time without notice is reserved.



FORD MOTOR COMPANY OF NEW ZEALAND LIMITED LOWER HUTT Licensed Motor Vehicle Dealer