

TD-9 SERIES B



INTERNATIONAL®

TOPS ANY CRAWLER IN ITS hp CLASS

Here's the most profitable do-it-yourself project you can undertake: Step into the operator's compartment of the INTERNATIONAL TD-9B and satisfy yourself it's the "best balanced" crawler tractor in its horsepower class.

The TD-9B is just right . . . best power-to-weight ratio, best size, and best stability from unit-engineered dozer construction.

The 75 net engine horsepower for the power shift model, and 66 horsepower for the gear drive version, is matched with 12,000 pounds of weight for best traction. No lost power here from track slippage. Fast-responding "282" engine maneuvers the "9" in and out of tight spots with ease.

With overall length at 10'3½" and width at 6'3", the TD-9B has a long, broad base for handling dozer or skidding loads. It rolls smoothly over any terrain, reducing "pitch" and throw.

And the "9" has been unit-engineered for "best balance," incorporating INTERNATIONAL's well-known three-point track suspension design with direct-lift dozer support arms mounted on that long, broad track frame base. Load and pull, for the first time, now are both right down on the ground, where both belong.

That's part of the story behind the "best-balanced" TD-9B. A trial run will convince you that it's the crawler for your jobs.

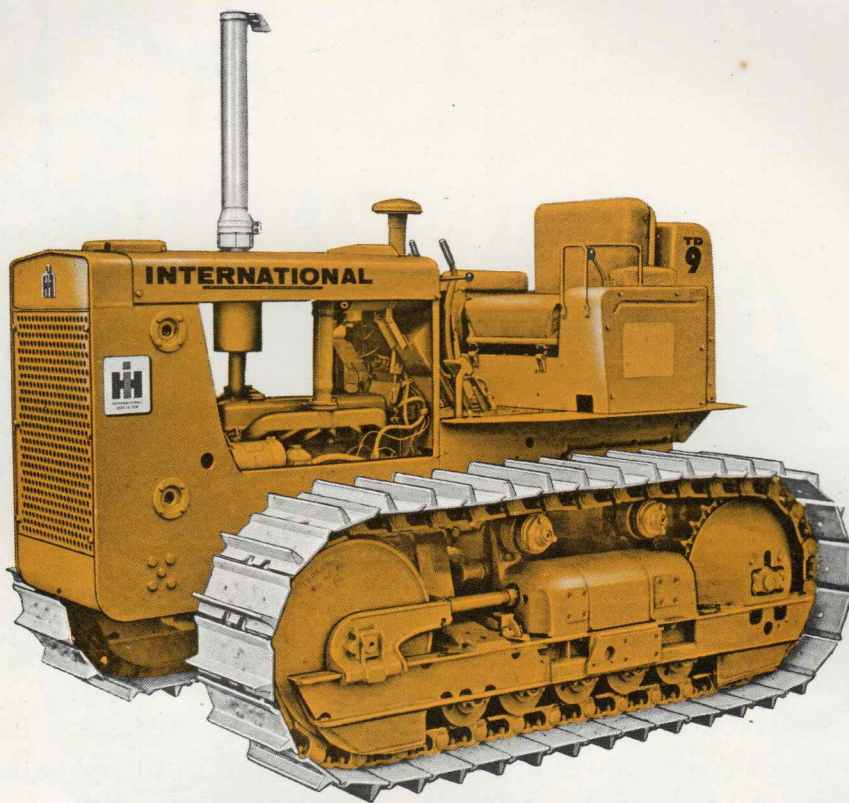

INTERNATIONAL TD-9B CRAWLER TRACTOR

BRIEF SPECIFICATIONS

| | Power Shift | Gear Drive |
|--|-------------|-------------|
| Number of track rollers (each side) | 5 | 5 |
| Net engine horsepower at flywheel | 75 | 66 |
| Drawbar horsepower | — | 56 |
| Drawbar pull, at rated rpm, lb. | 22,500* | 11,720* |
| Drawbar pull, max. torque engine speed (1350 rpm) | — | 14,500 |
| Speeds, forward | 2 | 5-4 |
| reverse | 2 | 1-2 |
| Speed ranges forward | 0 to 4.2 | 1.7 to 6.0 |
| reverse | 0 to 5.5 | 2.0 and 4.0 |
| Operating Weight. Approx. lbs. (tractor only) | 12,870 | 12,820 |

*At 0.5 mph with adequate weight and traction





SMOOTH, LOW-COST POWER



A notable improvement in the "282" is the INTERNATIONAL-designed rotary distributor fuel injection pump which delivers precise fuel charges to each injector with unflinching accuracy. Equally important, this pump is so easy to service, adjustments can be made on the job. Only the usual precautions are required against dust, moisture, and temperatures under field conditions. The flow of diesel fuel itself provides lubrication of the few moving parts.

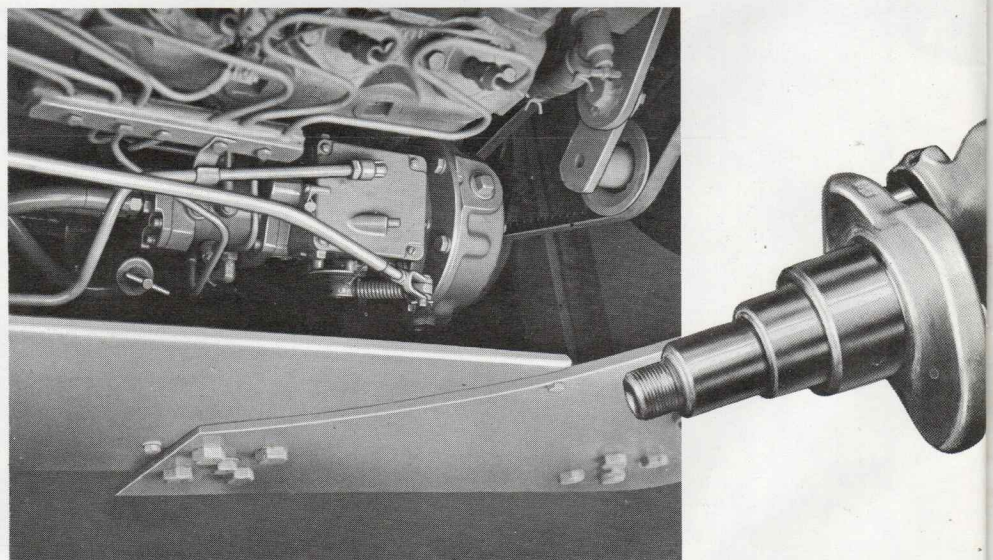

from a 6-cylinder Diesel Engine

Both the power-shift and gear drive TD-9B models are powered by the direct-starting INTERNATIONAL "282" diesels. In the power-shift model, the naturally-aspirated "282" develops 75 hp at 2300 rpm. In the gear drive "9" the turbocharged "282" gives 66 hp at 1700 rpm.

Economical? Yes. Precombustion chambers allow low-firing pressures and clean burning of diesel fuel under all loads and speeds, while the rotary fuel injection pump meters precise quantities of fuel for most efficient and economical fuel consumption per horsepower generated.

The "282" engine also features replaceable dry-type cylinder sleeves, low-friction aluminum pistons, positive valve rotators, and full-flow filtering, all assuring longer life to engine components operating in the crucial "heat zone." A big advantage to fleet owners is the interchangeability of engine parts with the INTERNATIONAL TD-6, TD-9B, and 150 loader. See other engine features that make the "282" unique in "9"-size crawler tractors.

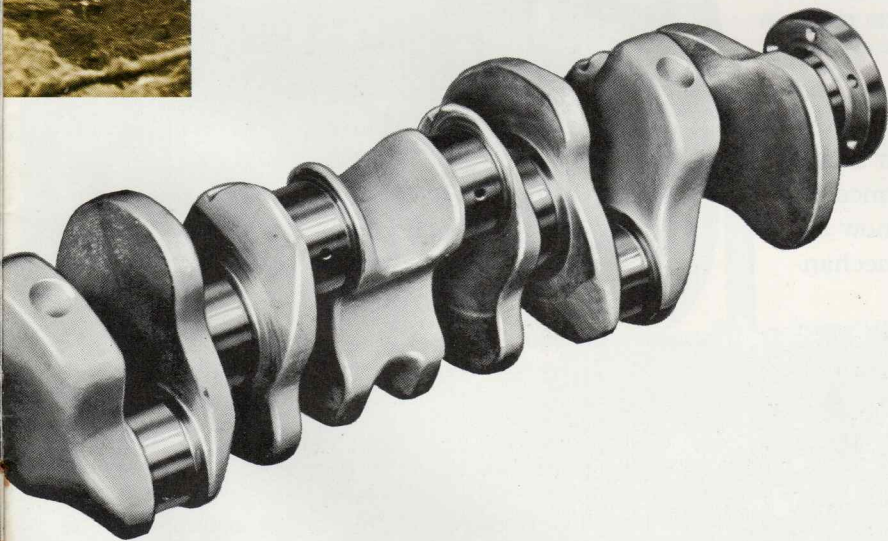

Balanced, Elotherm process-hardened crankshaft with depth-hardening extending into bearing surfaces and well into fillets to permit regrinding and refinishing, if necessary. This INTERNATIONAL process doubles crankshaft resistance to strain and wear to add years of performance.

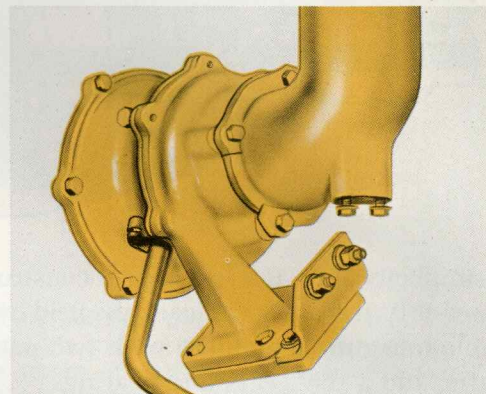
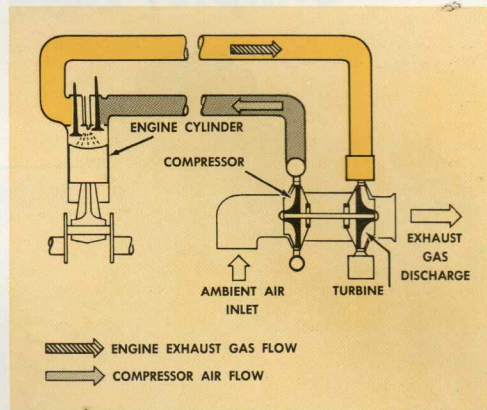

On gear drive models, a turbocharger creates a torque rise of 24%, cuts fuel costs, big advantages on any job. Use of this instant-action turbocharger with the "282" engine produces sustained high-power output, at altitudes up to 10,000 ft., and excellent fuel economy. As shown in the diagram, engine exhaust gases are used to drive a turbine on a common shaft with the compressor impeller. The impeller forces air into the intake manifold and supplies increased air volume, under pressure, for most efficient combustion at all loads and speeds. The turbocharger and bearings are lubricated and cooled by filtered engine oil supplied directly from the engine lube system, with usual gravity return.

TWO WAYS TO JOB PROFITS

simple, rugged, maintenance-free power shift

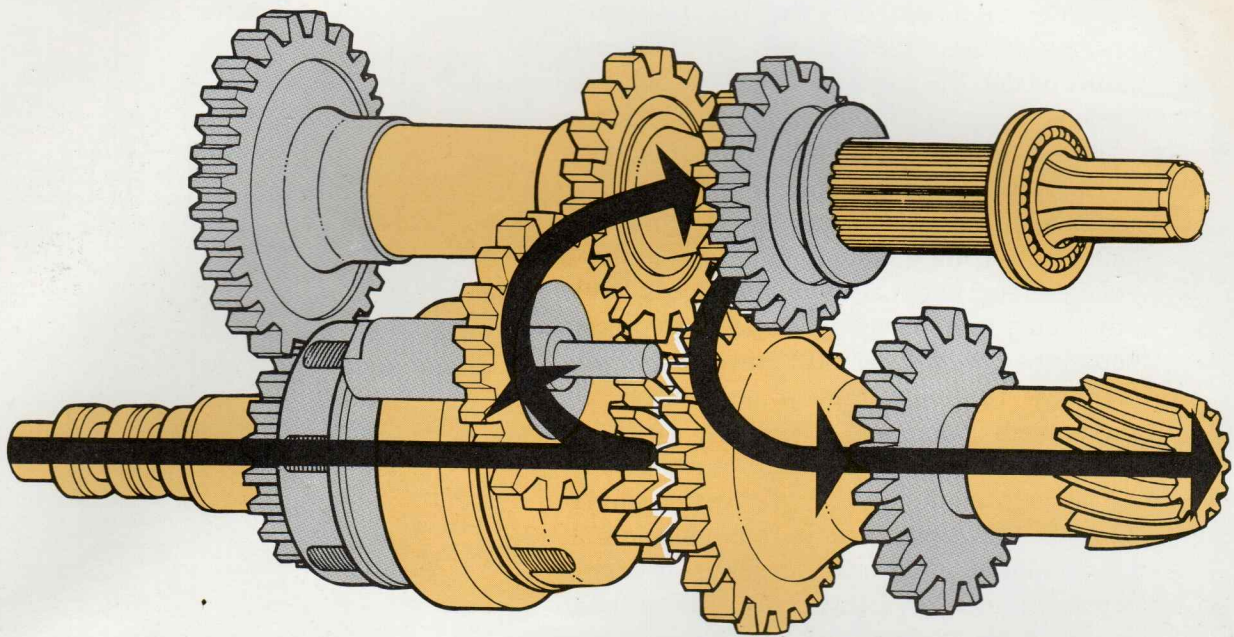

In simplicity of design and rugged construction, the power-shift transmission leads the field by a considerable margin. One clutch with two packs, three shafts, and a few gears and bearings . . . that's the whole, simple story. Everyone can appreciate the value of simplicity, especially maintenance men, along with the man who pays the bills.

In the power-shift transmission, engagement and disengagement of power is still the function of the clutch, now located within the transmission and a part of it. The clutch function is still performed by bringing together metal discs, though it is now accomplished by hydraulic pressure, not by mechanical action.

The operator simply directs the hydraulic pressure toward one pack or the other of the split clutch to get forward or reverse travel. Then, through a mechanical shift lever, a high or low range becomes available for either direction. The power-shift transmission above, for example, is in low-reverse position.

A single lube system serves both the torque converter and the transmission exclusively. A separate pump maintains lube pressure. A heat exchanger, located behind the radiator core, removes excess lube heat.

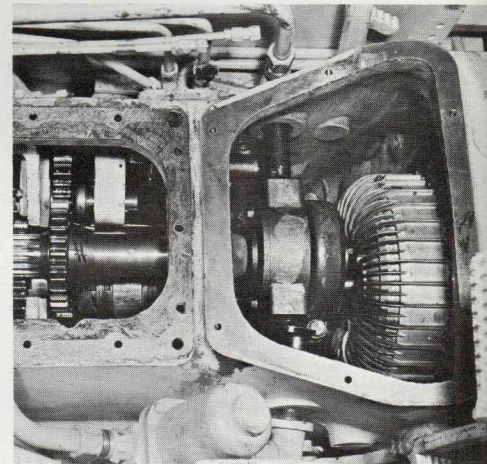
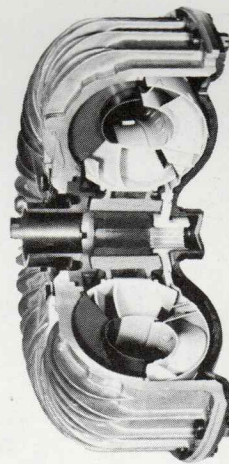

Coupled with the power-shift transmission is a torque-multiplying torque converter. This single-stage converter, driven by the flywheel, impels oil through a turbine wheel mounted on the driveshaft. A stationary housing redirects the oil through the turbine again and again, providing the torque-multiplying effect. The heavier the load, the more this converter changes engine speed into usable torque. Exceptional lugging ability is the result at the working end of the TD-9B, while oil cushions the effect of shock loads up in the operator's compartment.

or gear drive to match speeds to jobs

The long-life master clutch in gear drive models has ceramic-metallic button faces that will retain proper grip over a wide heat range and will not score the driven disc. Eliminated is the extra expense and bother of complicated liquid cooling. Because heat is rapidly dissipated, the clutch facings wear longer, require fewer clutch adjustments.

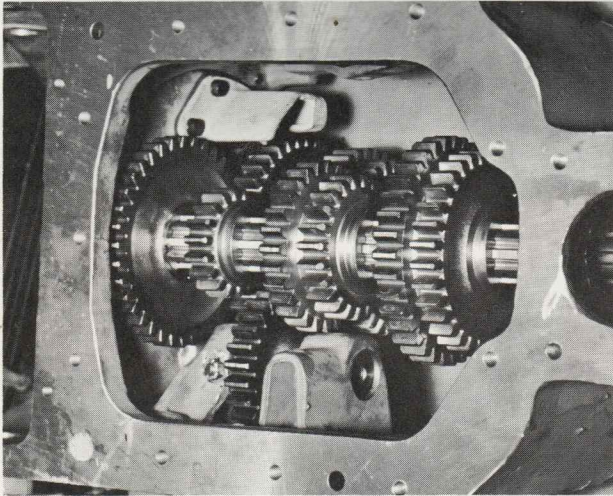
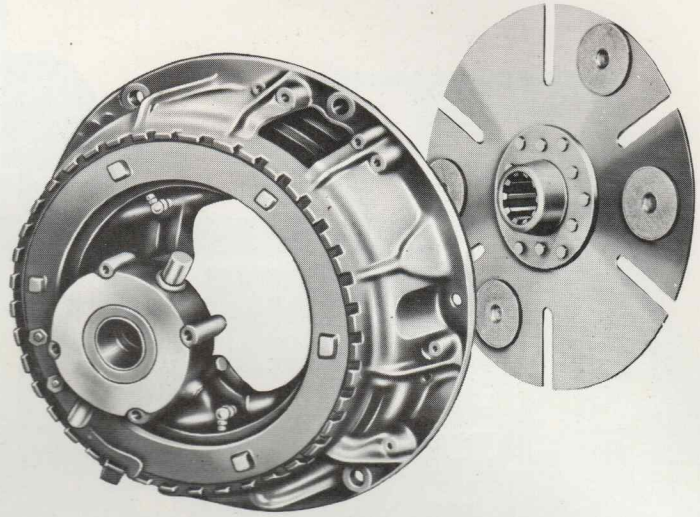

Two gear drive transmissions give right speeds, pulls for your jobs. Choose the one that will match your needs exactly—with five speeds forward and one reverse, or four speeds forward and two reverse. As compared with power shift models, the direct drive transmissions give the speeds and wide power ranges that contribute to superior TD-9B performance on "long-haul" assignments.



HEAVY FINAL DRIVE *key to*

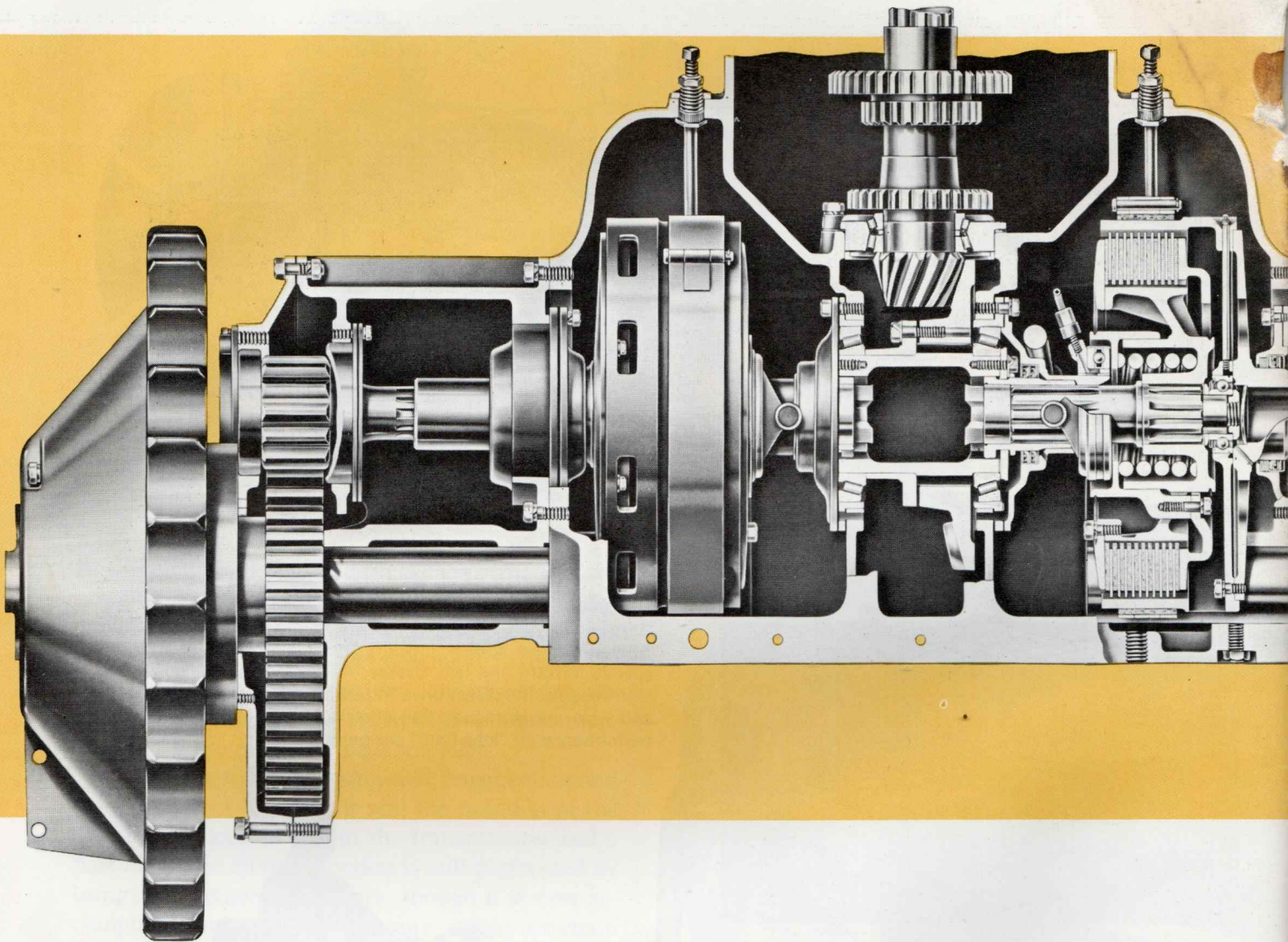

The unique TD-9B dozer design concept begins where power is applied . . . at the end of the final drive, obviously near the ground, at the sprocket. You'll find that's where the load is too. The TD-9B features a simple, direct line of power with single-reduction final drive, and matched gears of chrome-molybdenum steel for long, rugged service. Heavy-duty, anti-friction, bearing-mounted final drive shafts and single-reduction bull gears require no adjustment. This power train design efficiently

converts engine horsepower into workpower for thousands of more profitable operating hours.

Steering clutches let operators control that power under all load conditions. Steering boosters (standard equipment) reduce lever pull to lighten the operator's job and increase crawler maneuverability. Independent, foot-operated brakes encircle the clutch drums and assist in making feathered or pivot turns. Both the steering clutches and the steering brakes can be quickly and easily adjusted, or re-

unique dozer design

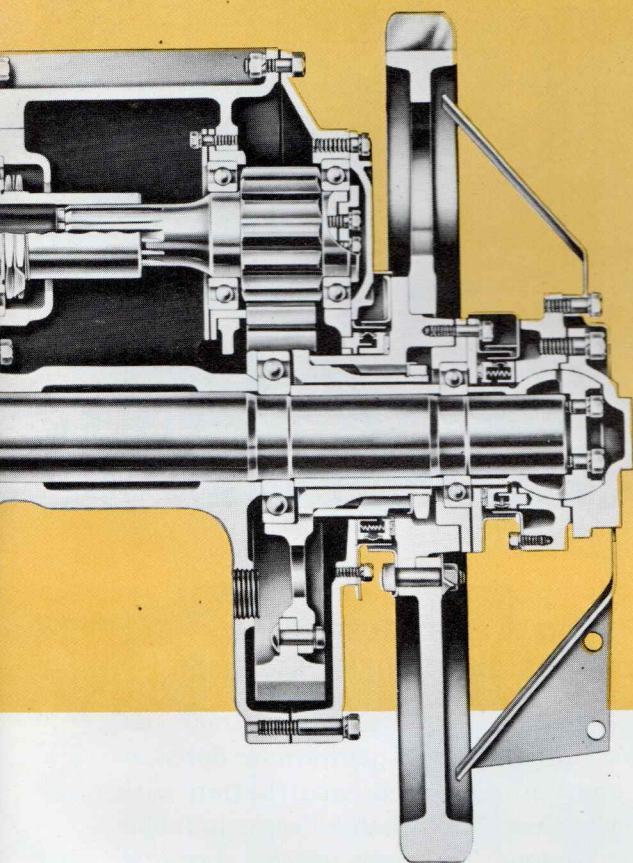

moved independently.

Mounting of the clutch shaft in pilot bearings provides easy, positive disengaging and better alignment. Metal driving discs are splined to outer drum, for rapid heat dissipation away from the clutch. Each clutch, measuring $14\frac{1}{8}$ in. in diameter, has 1,233 sq. in. of friction surface—far more than any competitive crawler. This extra capacity assures longer clutch life under heavy loads.

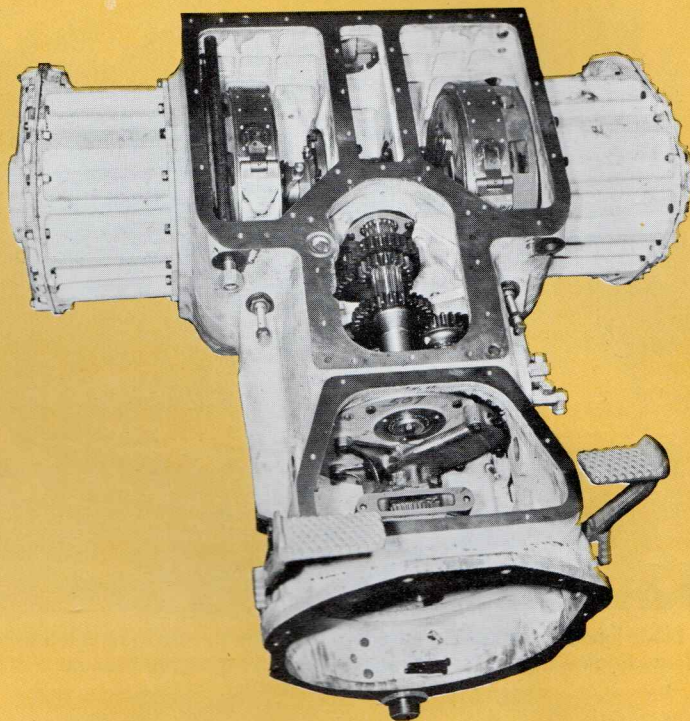

HEAVY MAIN CASE IS RUGGED BACKBONE FOR HEAVY DOZING

This heavy, rib-reinforced main case cradles the power train in its rigid frame, provides the solid foundation for the TD-9B. For it's the main frame that takes the brunt and strain when pulling equipment, skidding logs, or when using rear scarifier. This is where the heaviest loads belong; and the TD-9B puts 'em there.

RUGGED TRACKS



All blade loads and shocks are transmitted directly into the track frame where they belong. Engine frames, sheet metal, or tractor uprights bear none of the burden.

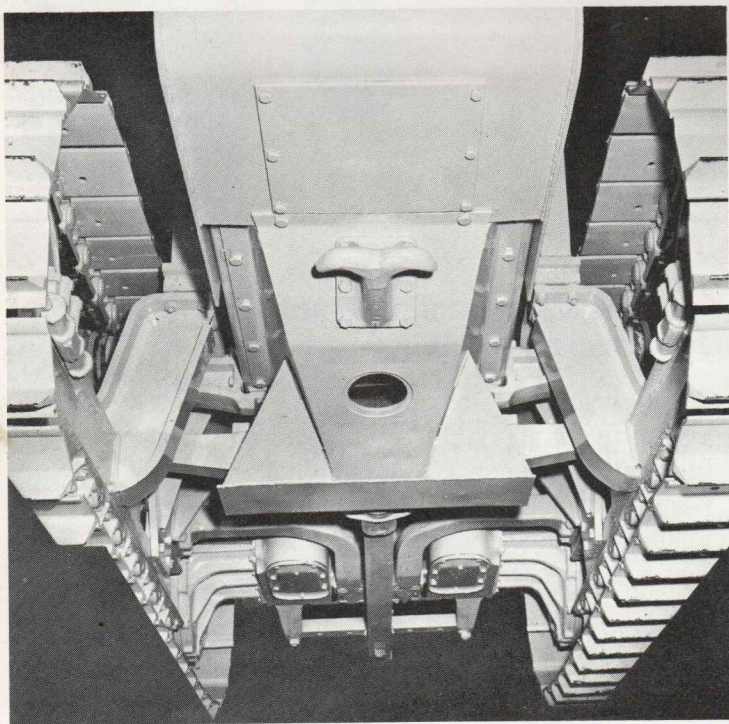

THREE-POINT SUSPENSION CREATES OUTSTANDING STABILITY

Exclusive INTERNATIONAL 3-point track suspension forms the broad platform for dozer action, combining rugged construction with intelligent design that enables tracks to follow ground contour. The track frames, shown in under view of crawler, are mounted on each end of a pivot shaft by a ball and socket joint. Frames are kept in vertical alignment by heavy steel diagonal arms that connect with pivot shaft by special bearings. Front guide roller and brackets keep tracks from toeing in or out. In addition, a front equalizer bar allows independent vertical track movements through saddle mounting between engine frame channels.

cut any terrain down to size

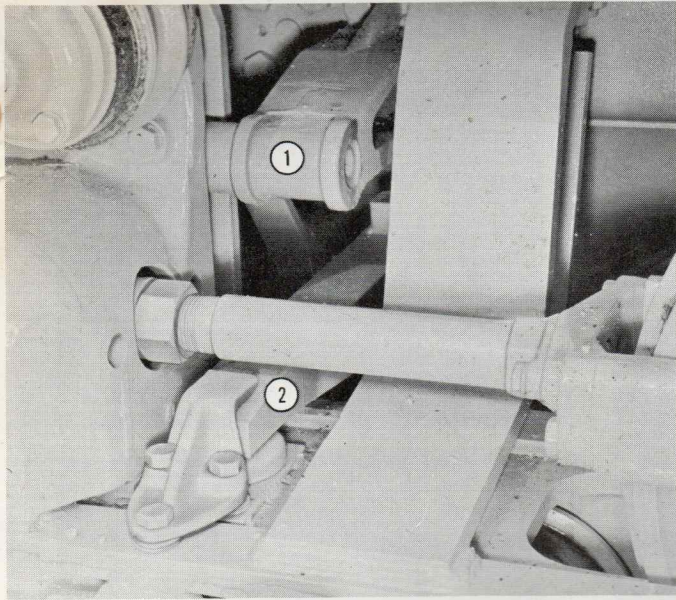

Track guides (1) check immediately the track frame leverage loads that build up from the front of the tracks during sharp pivot turns. The guides permit controlled vertical oscillation of track frames to meet ground contour, while solid equalizer bar (2) permits close blade control on fine grading applications.

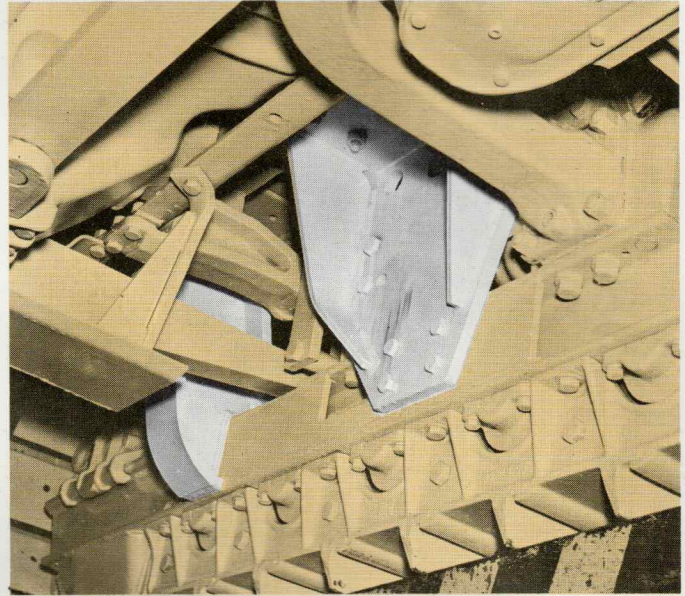

Underside showing heavy dozer support arms mounted in two places on rugged bar stock track frames.

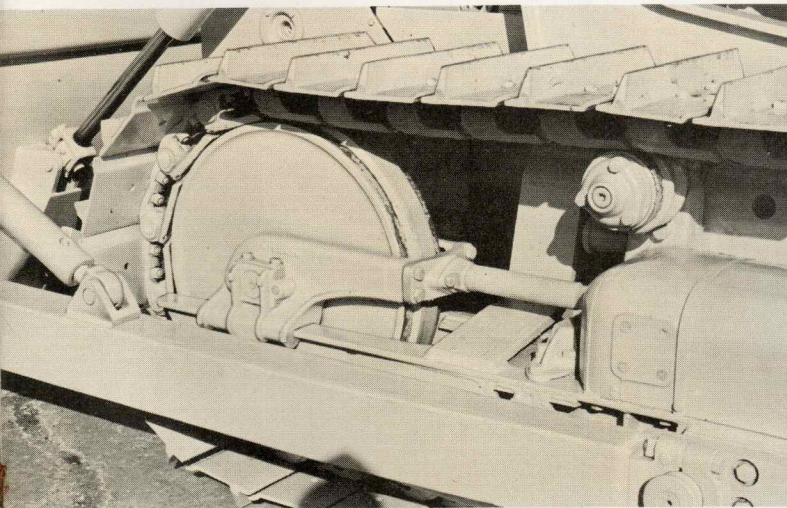

DRUM-TYPE FRONT IDLER IS SELF-CLEANING, has extended lube interval for economical maintenance. The track adjuster comes in two versions: the mechanical type is standard; hydraulic type is optional.

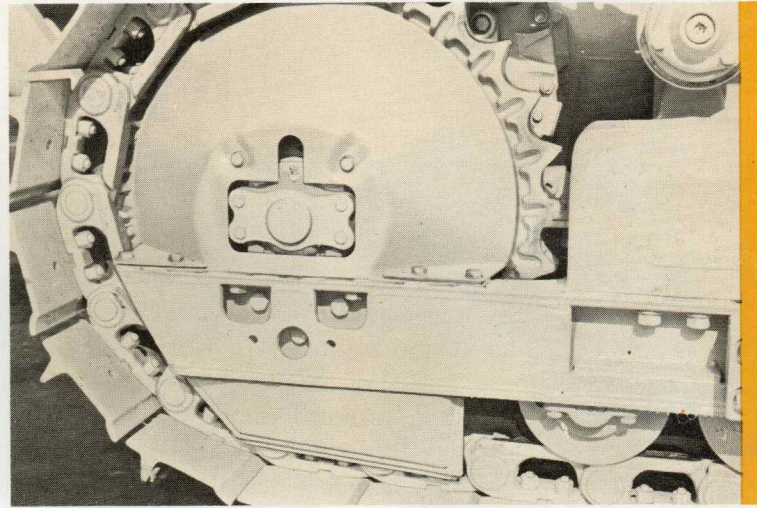

INDUCTION-HARDENED, HEAT-TREATED, STRUTLESS TRACK LINKS are a source of unqualified INTERNATIONAL pride for their long wearing capability. Famed "hunting tooth" sprocket design distributes wear evenly over track bushings, letting every sprocket tooth ride free half of the time to reduce wear.

HYDRAULIC

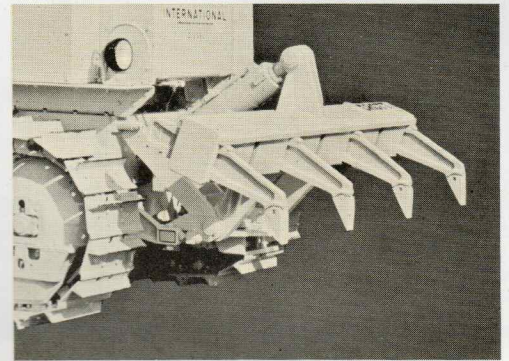
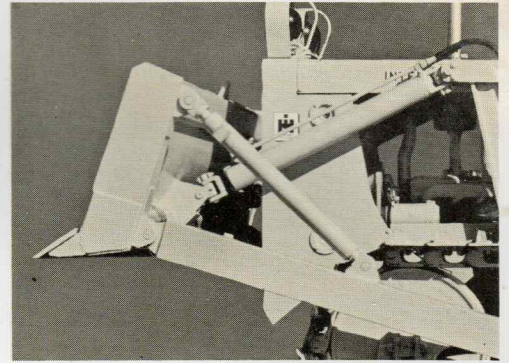
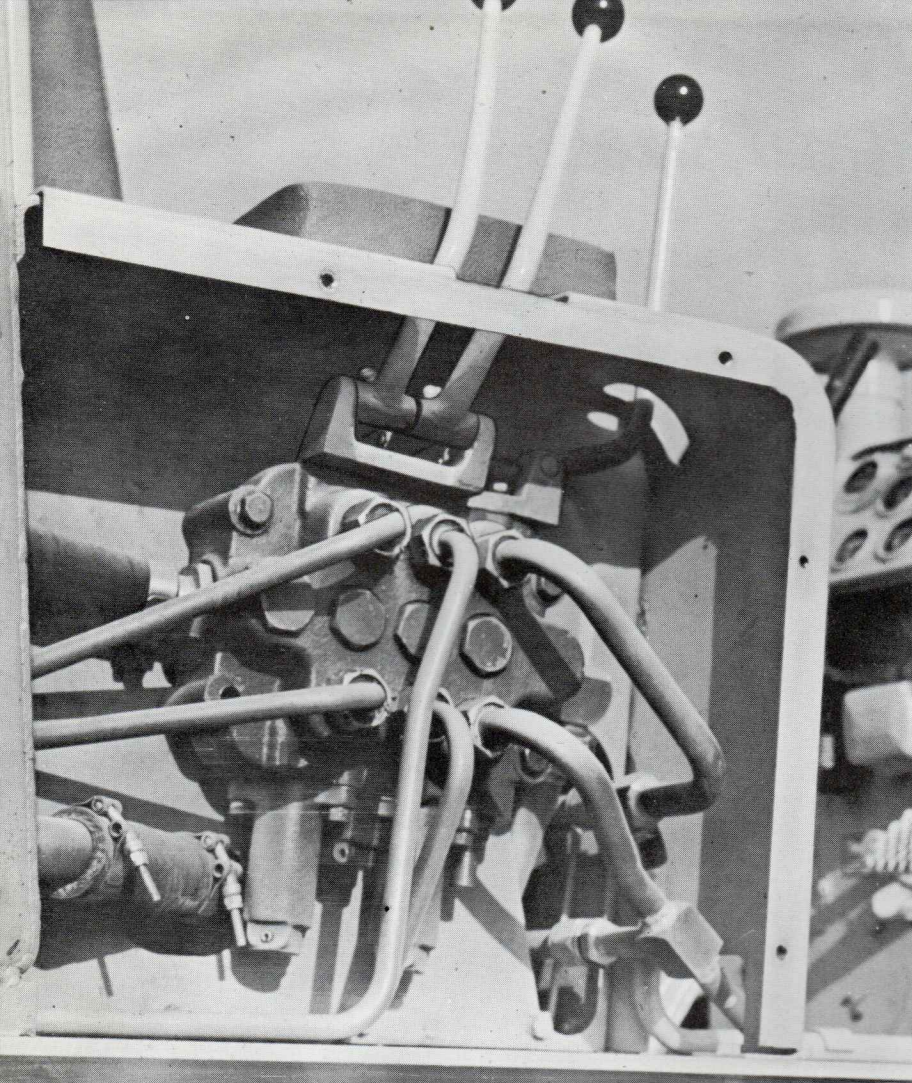

MAINTAINABILITY *cuts*

TD-9B maintainability puts equipment buyers and maintenance men at ease. Accessibility (filters, for example) is part of the story. But maintainability is wider in scope, ranging from the location of a grease fitting (or its elimination) to the unit design of the power-shift transmission. Service features and accessibility limit downtime. So maintainability is a big profit feature, even beyond the work a "Nine" will do and the job it performs.

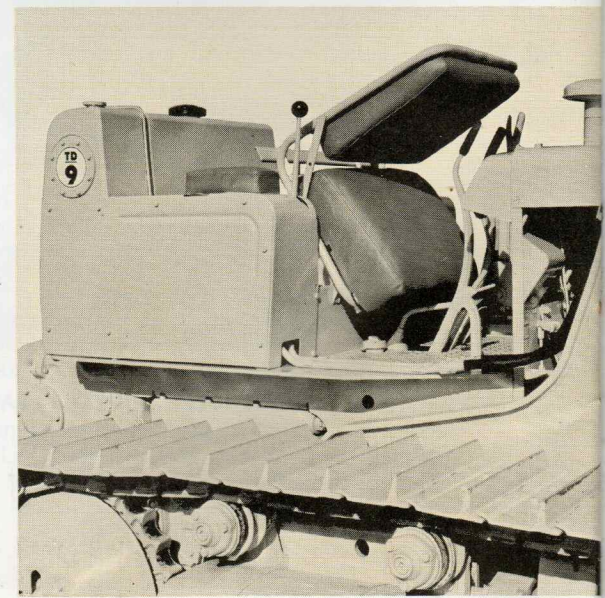

SYSTEM assures versatile performance

The TD-9B gives owners what they've wanted for so long. It's the optional three-spool hydraulic valve, with controls for front, rear, or pull-behind equipment. A single spool valve is standard on dozer models.

The control spool for "up front" attachments has four positions—raise, hold, float, and lower. The second optional spool lets you use the scarifier in raise, lower, and hold positions. Four positions for the third spool gives maximum control of pull-behind equipment. Together, these controls give the "9" a special versatility with all job-matched equipment.

Double-pin universal joints at top of hydraulic cylinders, as well as at the base of the blade, permit flexing within limits in any direction under working conditions normal to tractor-mounted equipment. Bullgrader and bulldozer blades are ruggedly constructed for heavy working conditions.

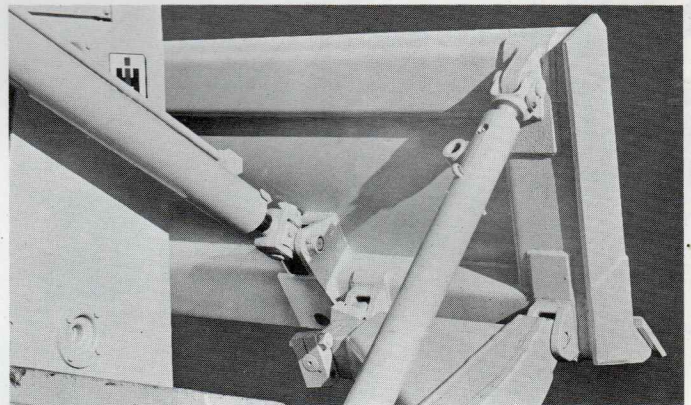
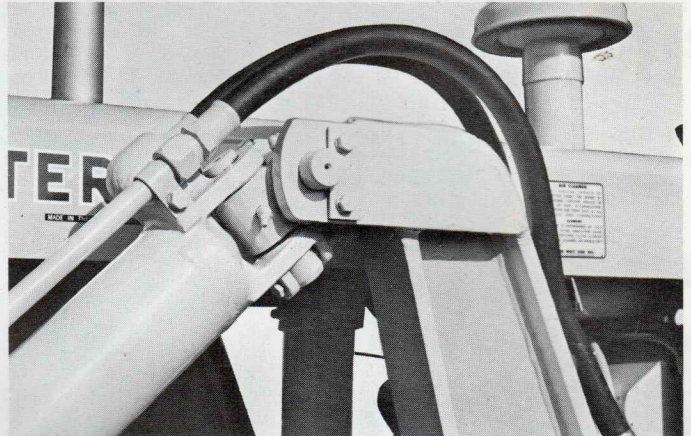

service time and costs

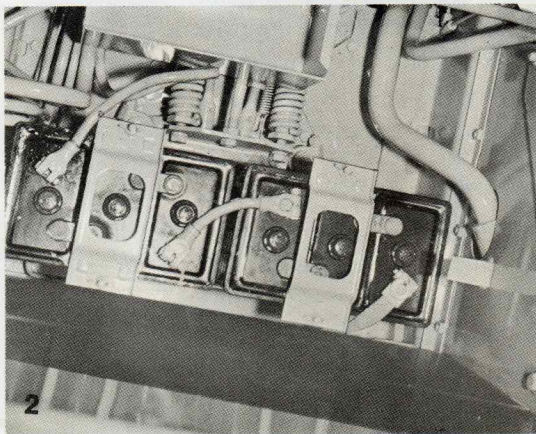

1. Tilt the seat forward... 2. and there are the two 6-volt batteries, in series. Accessibility is clean and uncluttered, plenty of room to get at 'em.

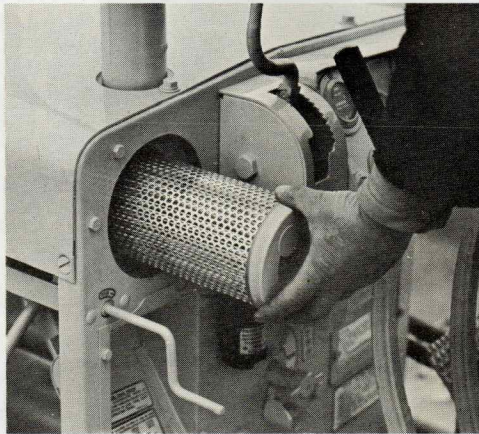

When your dash-mounted service indicator "stays locked-up in red," the filter needs changing or cleaning. Merely loosen one fitting and pull out the filter—simply and quickly—from the operator's compartment.

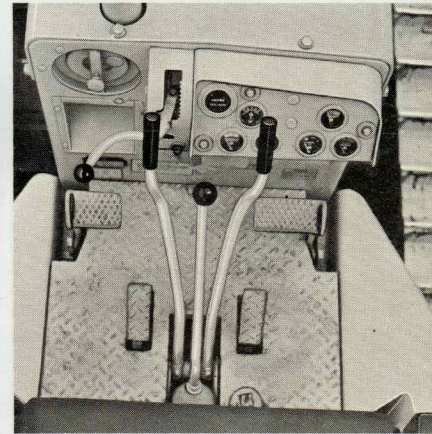

Just for safety's sake, an electrical cutoff switch below the dash disarms the electrical system and can be locked shut to prevent tampering and accidents after working hours.

FINGERTIP EASE OF OPERATION

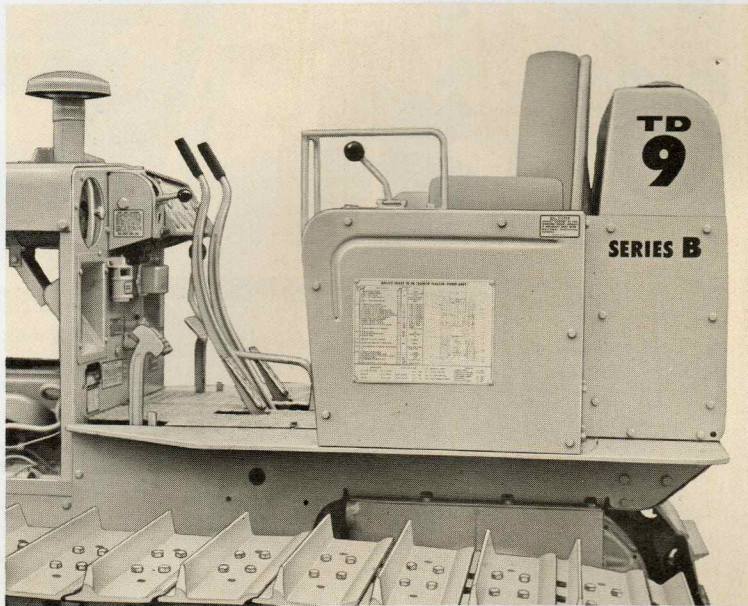

Operator's compartment in the standard power-shift dozer shows clean design and easy accessibility. Check these features:

- Power-shift lever just off the left arm rest.
- Mechanical shift lever conveniently located.
- Optional winch controls.
- Brakes where operators want them.
- Steering clutch levers at your fingertips.
- Throttle control near the dash.
- Decelerators are foot-operated.
- Hydraulic control to the right.
- Tank caps easy to reach, elevated to prevent dirt from falling in.
- Big, foam-rubber seat adjusts to any working position.

Complete line of attachments and accessories



The INTERNATIONAL TD-9B has matched attachments for special operating conditions or job applications to provide greater working efficiency and economy, to assure greater comfort and safety for operators, increased profit potential.

- Radiator Guard
- Crankcase Guard
- Front Pull Hook
- Woods radiator core and reversible fan
- Air Pipe Extension
- Rear PTO
- Hood Side Doors
- Lamp Guards
- Front Idler Shield
- Heavy-Duty Track Roller Shields
- Radiator Shutters
- Cigarette Lighter

TOWING WINCH

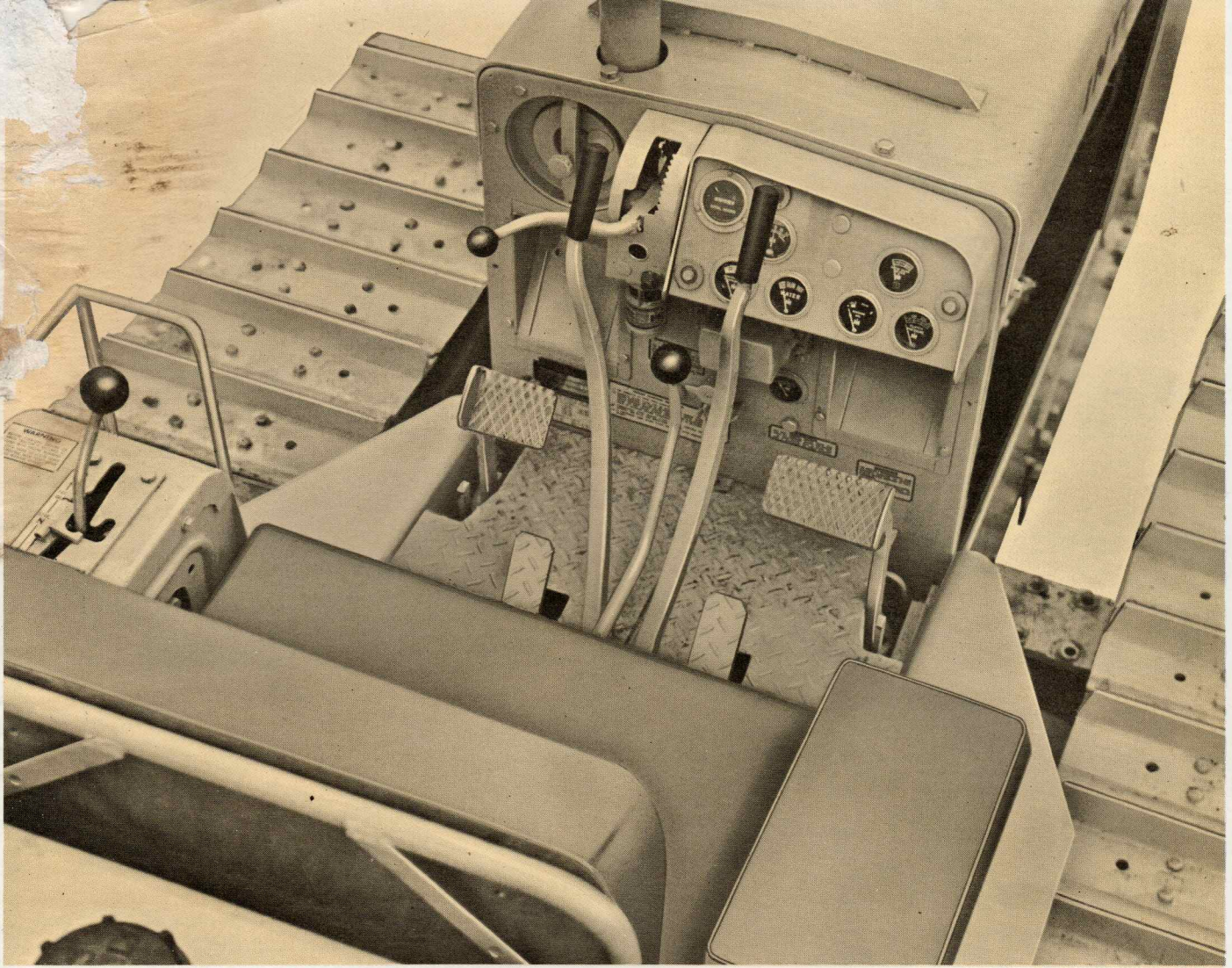

BULLGRADER



SCARIFIER



BULLDOZER



BEAT THE TOUGH JOBS WITH INTERNATIONAL® PAY POWER!

- DOZING
- GRADING
- BENCHING
- LEVELING
- STRIPPING
- HAULING

International Pay power proves its dependability on whipping tough jobs from beginning to end. Equipment that is built for long life, extra work and easier operation is your best bet for top profitability. Day-in day-out International products will perform up to your expectations.

The International line incorporates all of the best most recent developments in the construction machinery industry along with many exclusive features. Get the inside reasons behind the switch to International from your International Distributor.

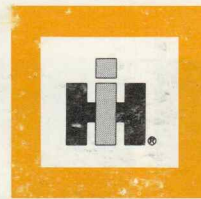

***International®
Construction
Equipment***

Specifications subject to change without notice.

**INTERNATIONAL HARVESTER EXPORT COMPANY
CHICAGO, ILLINOIS, U. S. A.**