

Mercedes-Benz

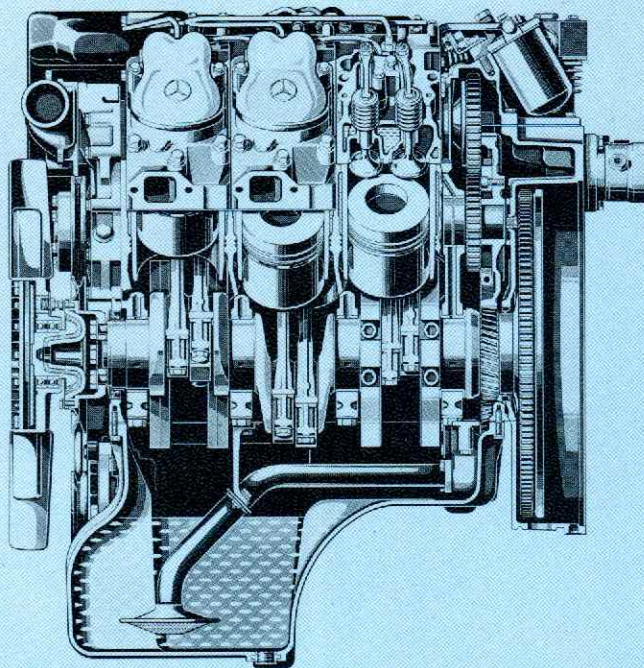

# Engine OM 401

with G 3/60-5/7.5  
gearbox



This Mercedes-Benz diesel V-engine from the 400 series is a practical example of the application of advanced engineering principles and new technologies. Special advantages of the V-arrangement of the cylinders: low weight and little space required. The sturdiness and economy of Mercedes-Benz V-engines come up to the most advanced standards in present-day engine technology.

Mercedes-Benz diesel V-engines of the 400 series are built on the unit construction principle, whereby 86% of the components for all V-engines are identical and thus easily interchangeable. This facilitates spare parts storage, and repairs can be carried out more easily, more rapidly and thus at lower cost.

### Short description

Robust V-engine with direct diesel injection. Complete combustion results in low fuel consumption – hence low operating costs. Smooth-running engine, little smoke emission – hence less environmental pollution. Water cooling ensures even thermal values. Engine output: 192 DIN/hp, 141 kW. Max. torque: 64 mkp at 1,300 rpm or 627 Nm at 1,300/min

Mercedes-Benz OM 401

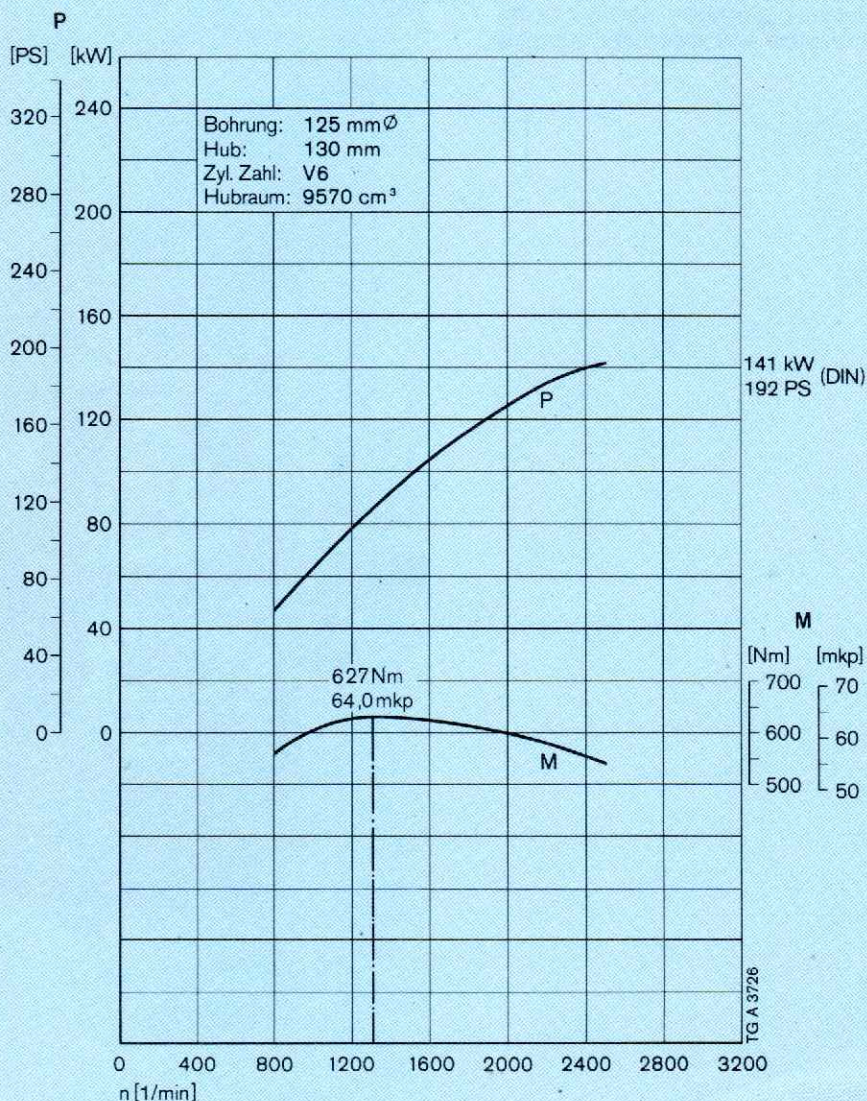

Mercedes-Benz



## Engine OM 401

with G 3/60-5/7.5  
gearbox

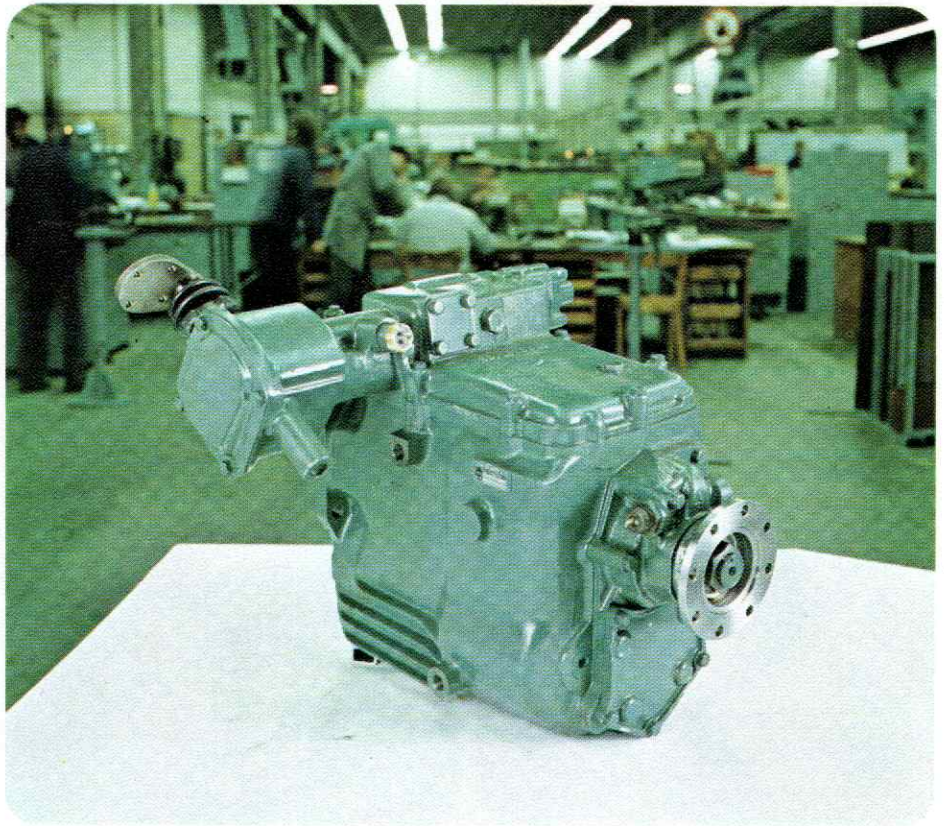

**F**ive-speed synchromesh gearbox, one reverse gear. For smooth, economical driving and gearshifting without double-declutching. Perfectly matched to the performance and speed of the engine.

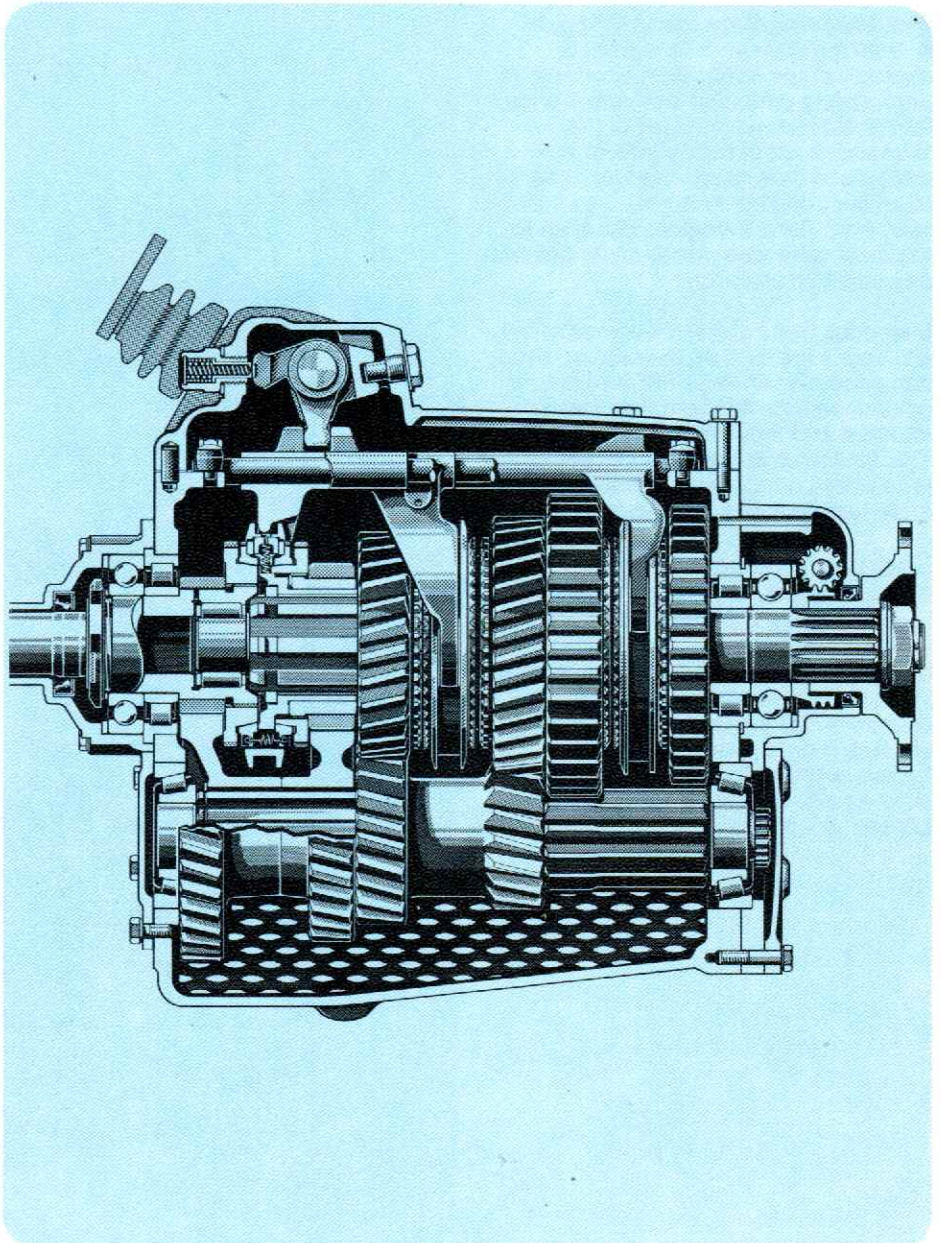

Mercedes-Benz

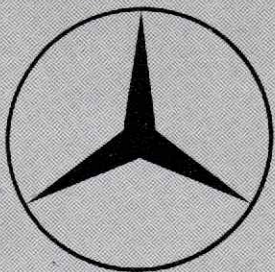

# Engine OM 401

with G 3/65-9/13.36 GP  
or G 3/65-8/9.29  
gearbox

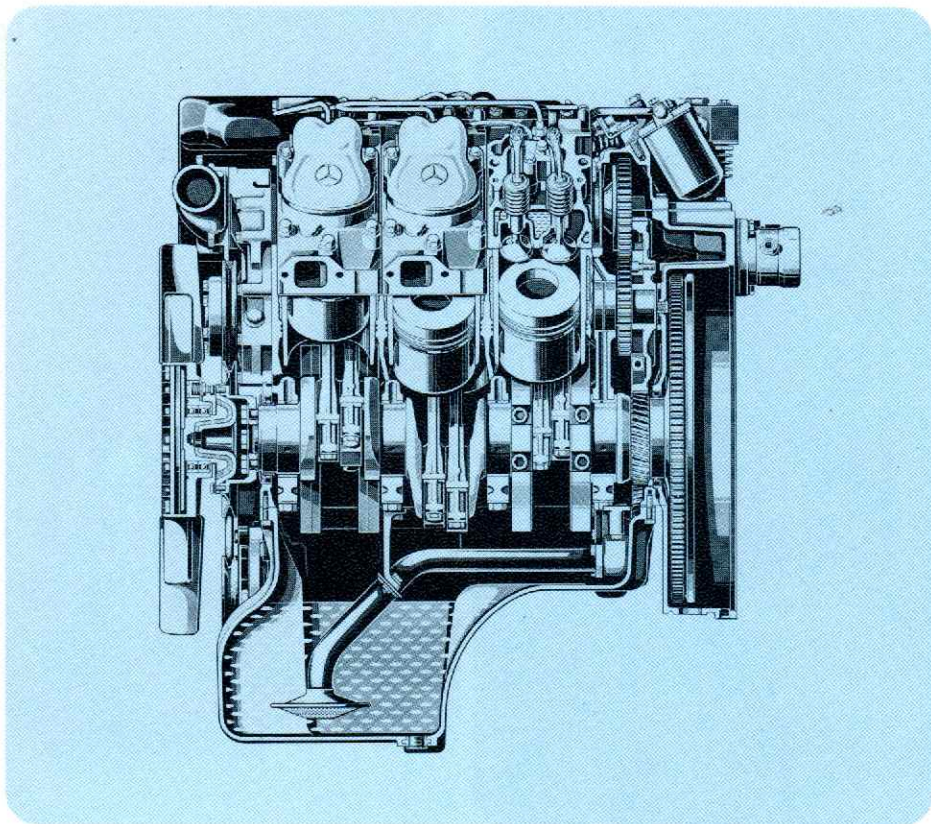

This Mercedes-Benz diesel V-engine from the 400 series is a practical example of the application of advanced engineering principles and new technologies. Special advantages of the V-arrangement of the cylinders: low weight and little space required. The sturdiness and economy of Mercedes-Benz V-engines come up to the most advanced standards in present-day engine technology.

Mercedes-Benz diesel V-engines of the 400 series are built on the unit construction principle, whereby 86% of the components for all V-engines are identical and thus easily interchangeable. This facilitates spare parts storage, and repairs can be carried out more easily, more rapidly and thus at lower cost.

### Short description

Robust V-engine with direct diesel injection. Complete combustion results in low fuel consumption – hence low operating costs. Smooth-running engine, little smoke emission – hence less environmental pollution. Water cooling ensures even thermal values. Engine output: 192 DIN/hp, 141 kW  
Max. torque: 64 mkp at 1,300 rpm or 627 Nm at 1,300/min

Mercedes-Benz OM 401

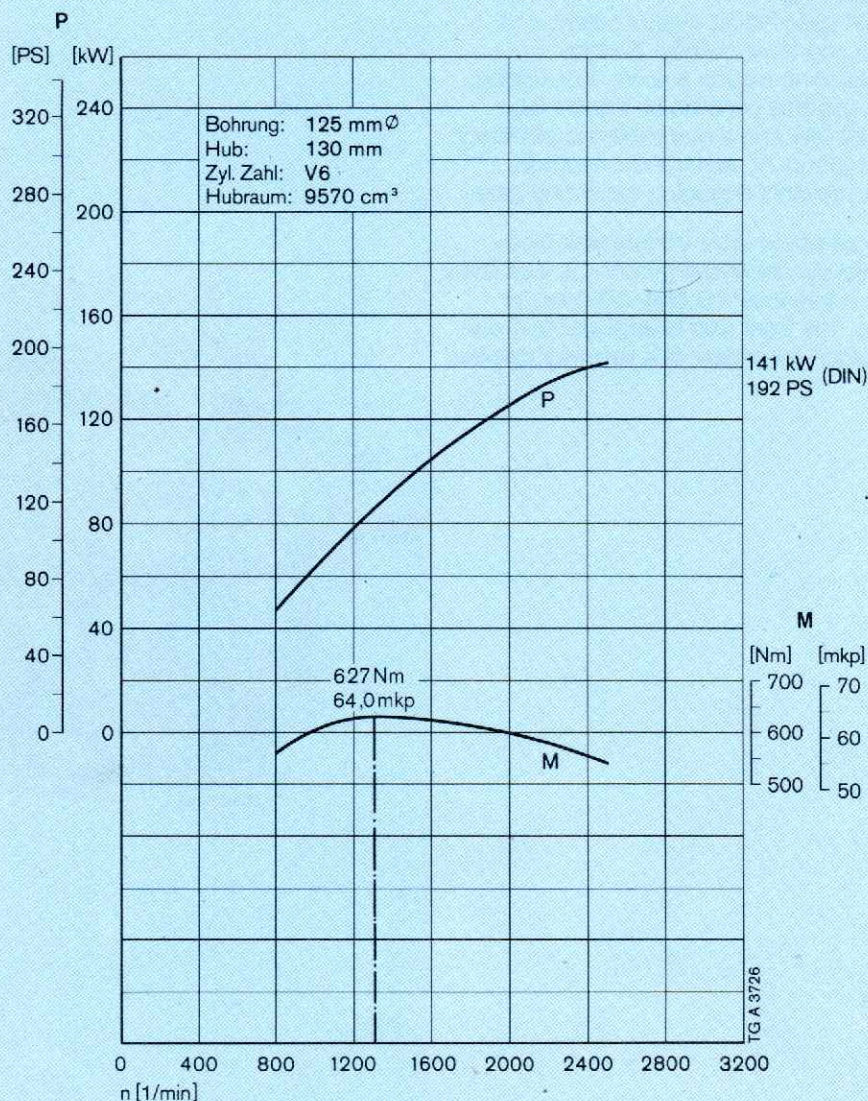

Mercedes-Benz

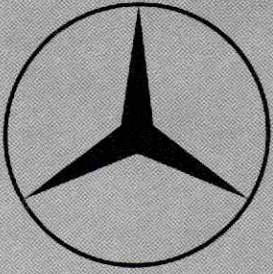

## Engine OM 401

with G 3/65-9/13.36 GP  
or G 3/65-8/9.29  
gearbox

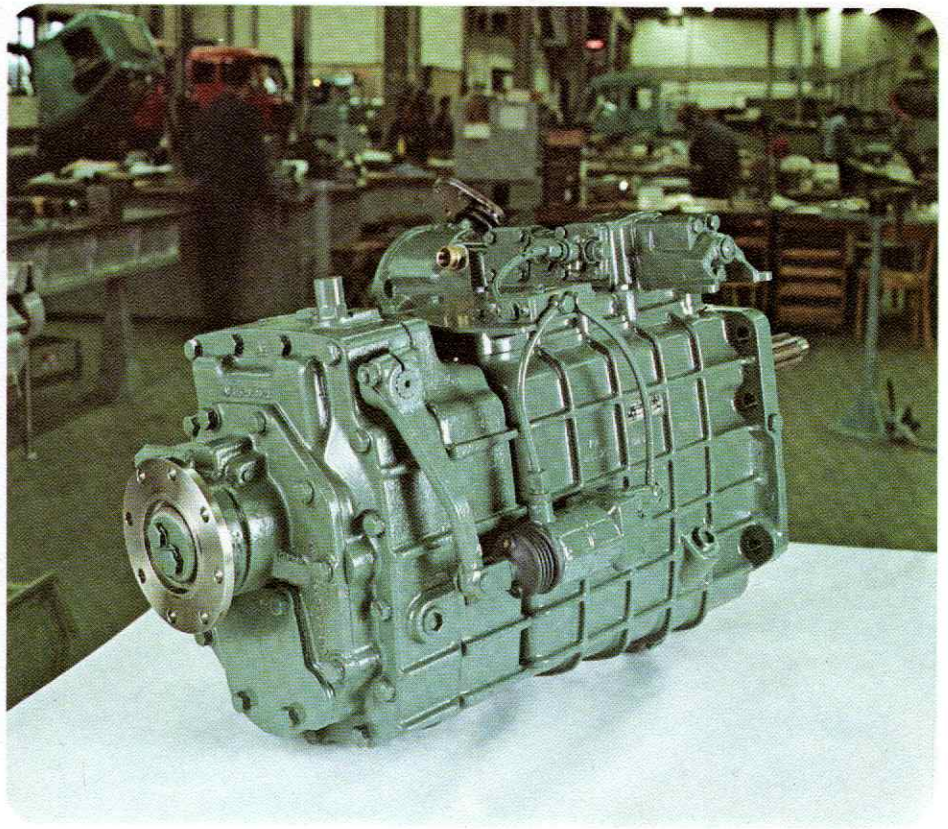

**E**ight-speed synchromesh gearbox with or without crawler gear. One reverse gear. Rapid gearshifting means safety, and changing down without double-declutching means smooth, fast driving. The gearbox consists of a basic four-speed unit and a rear-mounted planetary gear group. An electronic-pneumatic lock prevents engaging the wrong gear.

The all-wheel drive vehicle with nine-speed synchromesh gearbox is also fitted with a separate VG 850-3W transfer case. The front axle is engaged and disengaged by means of a two-way cylinder.

