

THE DOMINION MOTORS LTD.
(Licensed Motor Vehicle Dealers)

455 BROADWAY, NEWMARKET
PHONE 545-099

NUFFIELD

BMC
DIESEL

NUFFIELD

BMC NUFFIELD
3/45 & 4/65

BMC NUFFIELD 3/45

Two views of the BMC Nuffield 3/45. The three-cylinder BMC diesel develops 45 b.h.p. Available in Basic, Standard or De-luxe specifications. A 10-speed gearbox (two reverse ratios) is standard on all models.

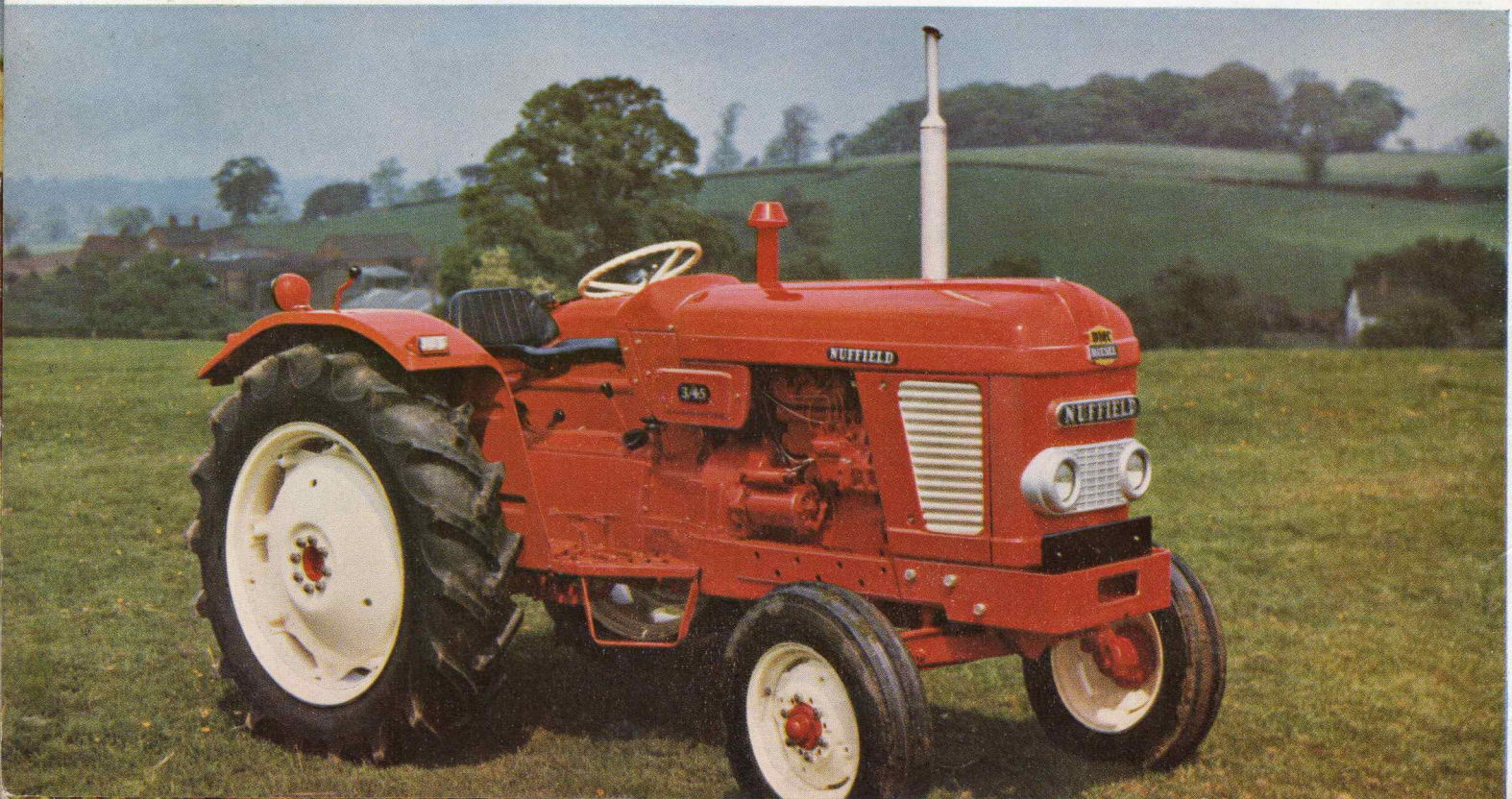

BMC **NUFFIELD** 4/65

Three-quarter rear and side views of the 65 b.h.p. BMC Nuffield 4/65 with four-cylinder BMC diesel and 10-speed gearbox (two reverse ratios). Like the smaller 3/45, the 4/65 is available in Basic, Standard or De-luxe specifications.



built around the driver

Designed entirely with the driver's needs in mind, big usable power is allied to optimum 'working conditions'. Easy to mount and dismount, generous-sized floor plates are provided. Gear levers, throttle lever, and all controls are placed exactly where the driver's hands and feet dictate. A comprehensive range of instruments is housed in a weather-tight panel forward of the steering-wheel. For additional comfort a de-luxe suspension seat is available (optional extra). All these features combine in reducing driver fatigue, which in turn materially increases output.

Safety

The 3/45 and 4/65, by reason of their inherent stability and safety-inspired detail design, are amongst the world's safest tractors. The driver can mount or dismount easily; controls or levers do not form dangerous projections; the mudwings are wide and strong; P.T.O. shields are provided in conformity with regulations; and the wide foot plates have non-slip surfaces. On both models a cut-out switch prevents the engine being started whilst a gear is engaged.

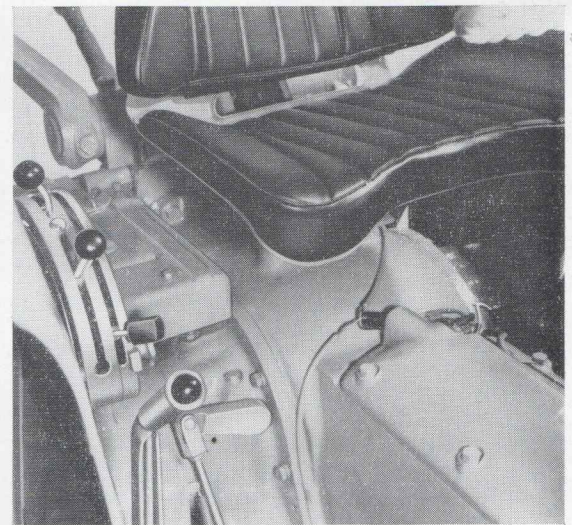
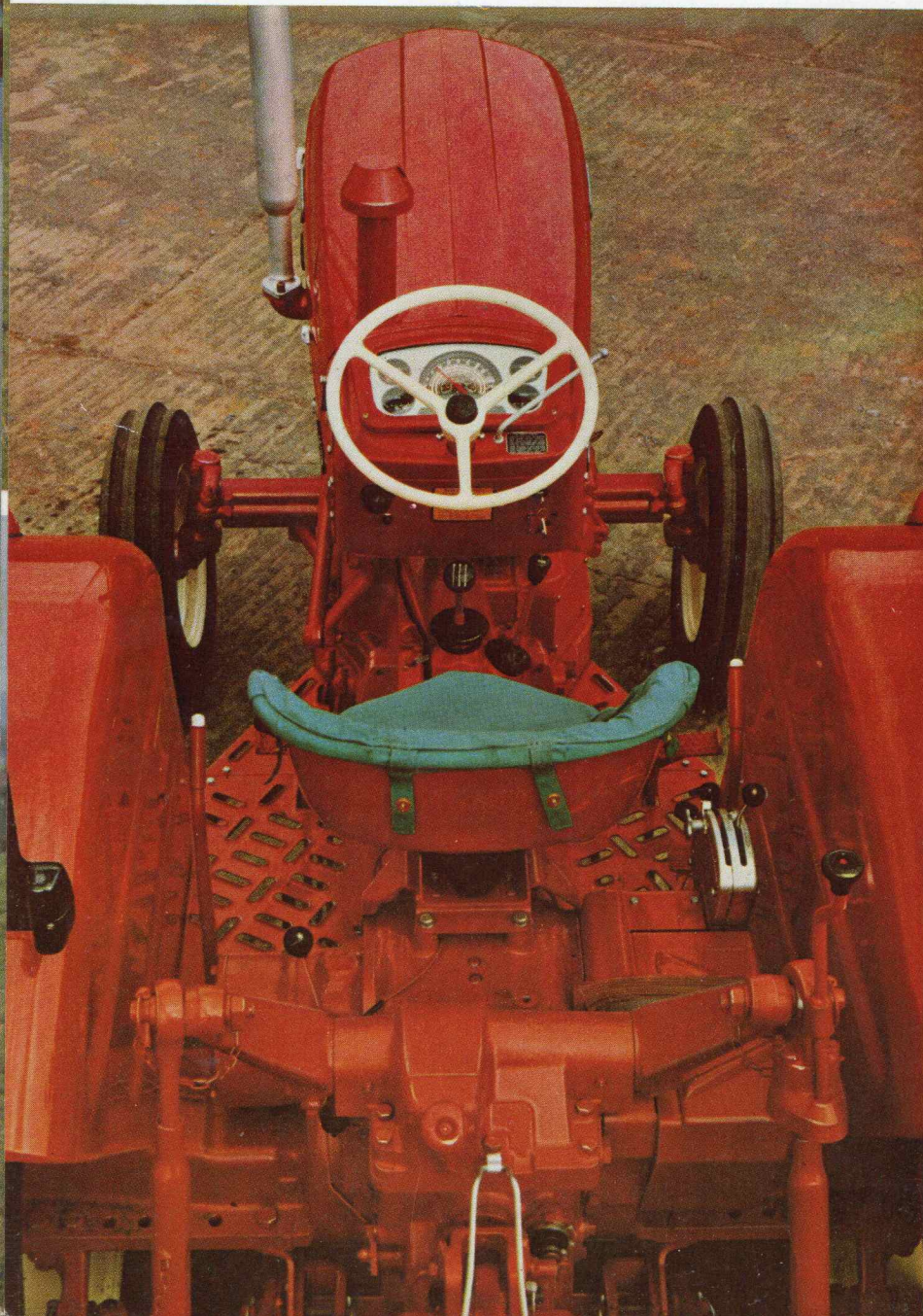
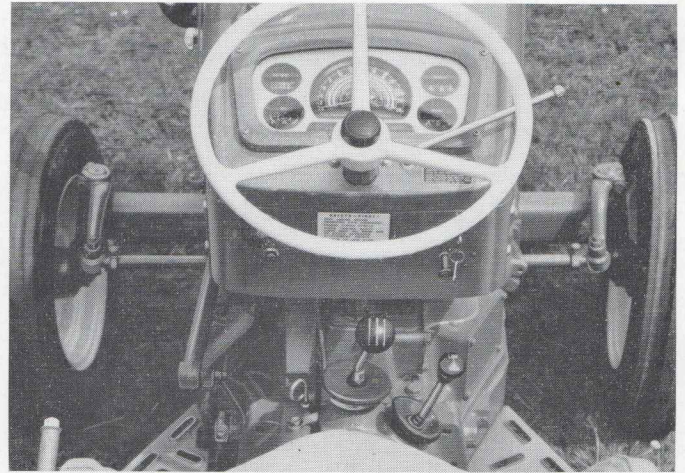

All three hydraulic controls, main, auxiliary, and draught, are grouped in one quadrant assembly.

The hand-brake lever, placed close to the mudwing, causes no obstruction. The differential lock pedal is heel-operated. Twin foot-brake pedals can be used independently to assist steering or latched together for road work.





NUFFIELD DRAUGHT CONTROL

Operation of the hydraulics is controlled by three levers, which are grouped together in one quadrant to give completely independent operation of the tractor linkage, depth control, and auxiliary equipment.

Only Nuffield tractors have two completely independent spool valves as standard for operating the tractor linkage and external equipment respectively. Additionally, the oil flow is controlled to limit the lowering rate, and detent pistons return the hydraulic levers to the neutral position when maximum pressure is attained on the pump. The main control lever raises and lowers the hydraulic linkage and also selects the depth control circuit, when in the fully lowered position.

A quick rate of penetration can be effected by moving the main lever to a position half-way between neutral and the full drop detent, when the rate of drop is independent of the depth control setting. When the required depth is reached, the depth control is brought into operation by selecting the full drop detent on the main lever.

The depth control valve operation gives smooth implement control with *continuous* weight transference. A flow control valve, incorporated in the circuit, ensures that the selected depth is maintained independently of the engine r.p.m. The required working depth is manually selected by the position of the draught control lever on the quadrant and the selected depth is automatically maintained.

The double-acting top link spring ensures good depth control of heavy implements, working both in deep and shallow conditions. The third lever on the quadrant operates the external services and, in conjunction with this lever, a tapping on the hydraulic case makes possible the coupling of the hydraulics to the external services. The hydraulic linkage can be locked in the fully raised position by the use of the conveniently positioned mechanical locking latch.

The lower end of the top link and draught control plunger can be seen in the picture below. Also the well-protected P.T.O. and swinging drawbar. The automatic pick-up hitch shown is a proprietary fitment available as an extra from Dealers.

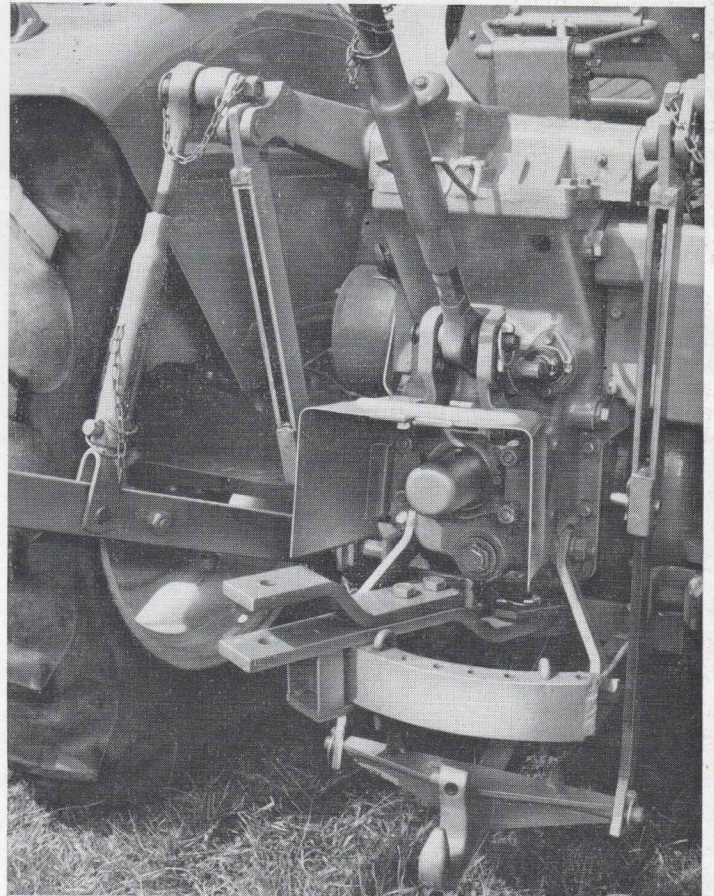

big usable power

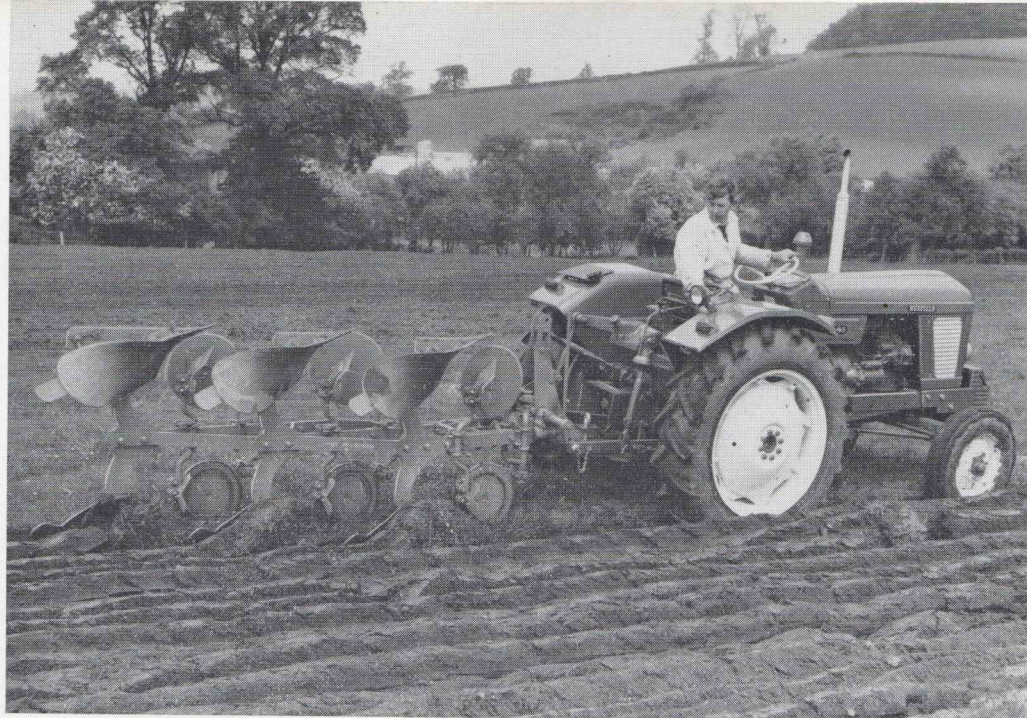

The BMC Nuffield 3/45 and 4/65 tractors employ high-efficiency BMC diesel engines of three and four cylinders respectively. Both are direct injection, the three-cylinder is of 2827 c.c. and the four-cylinder of 3770 c.c., with maximum torque in the 1,600 r.p.m. range to provide lugging power where and when it is needed.

The 3/45 develops 39 P.T.O. h.p. at 1,800 engine r.p.m. with a P.T.O. speed of 540 r.p.m. The 4/65 develops 54 P.T.O. h.p. at 1,800 engine r.p.m. with a P.T.O. speed of 540 r.p.m.

BMC are among the largest manufacturers of diesel engines in the world. Produced in one of the newest and most modern plants in Europe, BMC diesels power products in every country in the world from small boats to heavy industrial excavators as well as cars, trucks, and tractors.

Unmatched for power with economy and reliability, BMC power speeds the plough the world over.

BMC NUFFIELD 3/45 2.8 LITRES DIESEL
3 cyl., 100 mm. bore, 120 mm. stroke

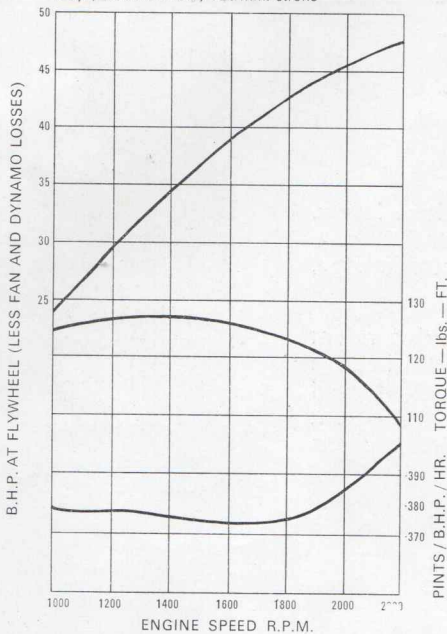

BMC NUFFIELD 4/65 3.8 LITRES DIESEL
4 cyl., 100 mm. bore, 120 mm. stroke

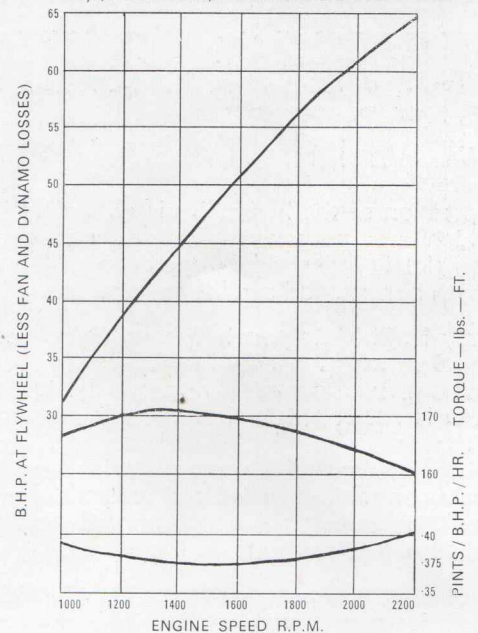

The robust engine hood, hinged on the right-hand side, can be raised without disturbing the exhaust pipe. Accessibility is excellent. Note the steering drag link which is housed within the protection of the main frame.

On both the 3/45 and 4/65 the 15-gallon fuel tank is mounted ahead of the engine. The tank is well protected, and in this forward position does not diminish the driver's working space.

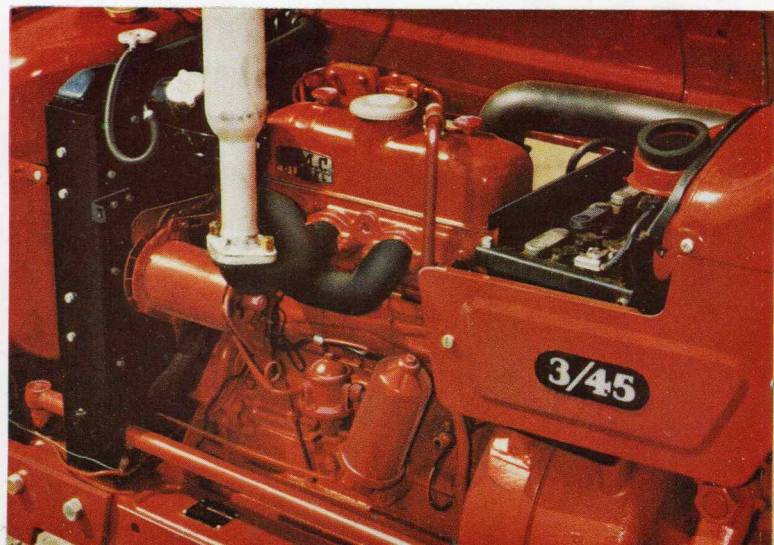
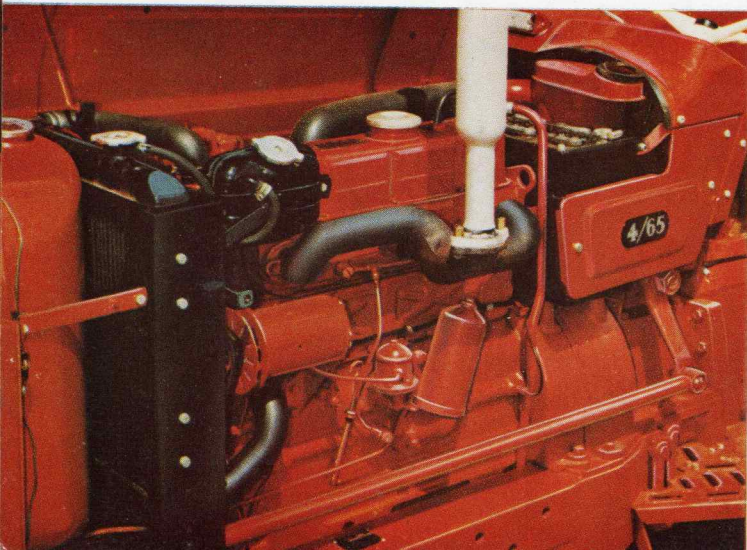

accessibility

Nuffield tractors have always been considered the easiest to service. Routine servicing is simple work; the engine is immediately accessible, so also is the air filter, the fuel pump, battery, starter motor and dynamo. Even a major servicing job such as clutch dismantling is not a formidable task since a substantial stress-bearing main frame supports the power unit and obviates the usual necessity of dividing the tractor into two parts to gain access to the clutch.

Power-assisted steering (optional extra) is available on the 3/45 and 4/65. The illustration shows the hydraulic pump which is driven from the rear of the timing case

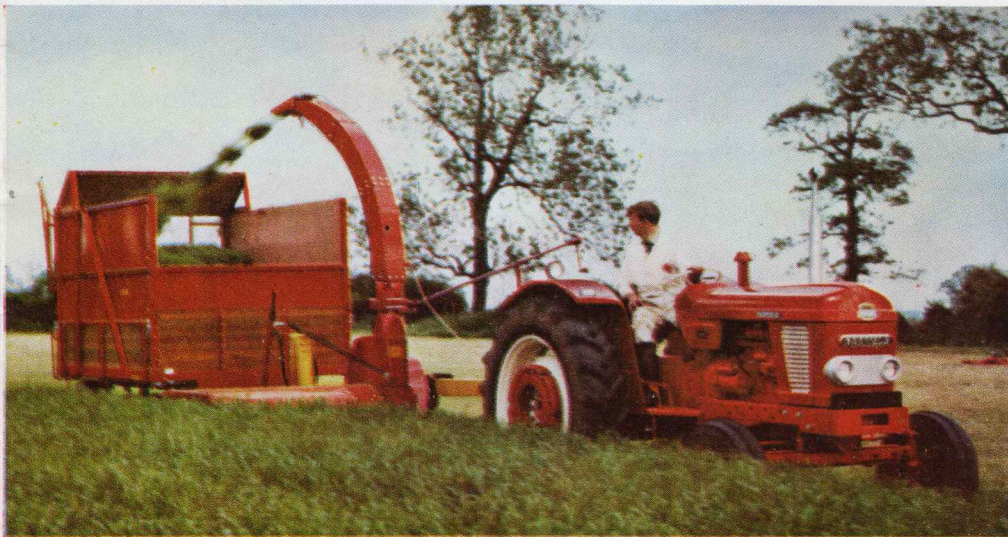
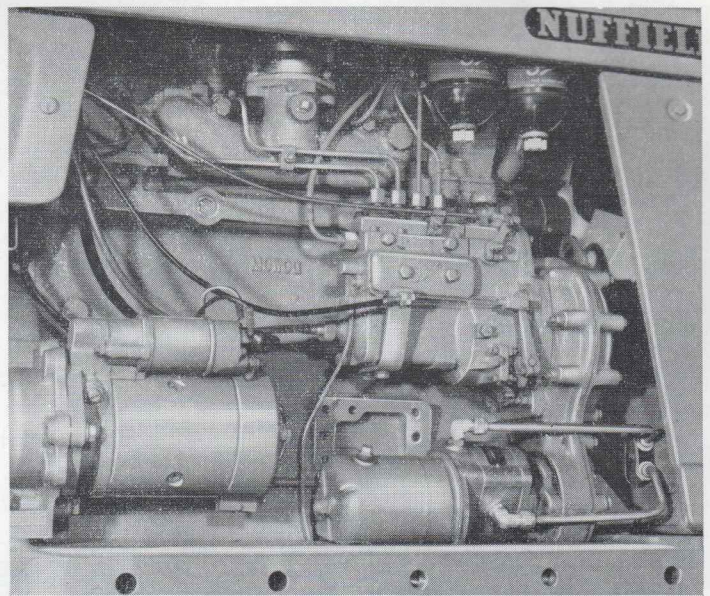

ten forward speeds and two reverse

The 3/45 and 4/65 have 10-speed gearboxes (plus two reverse gears). With eight forward speeds for field work, two speeds for road work and two reverse speeds the optimum ratio is available for every task. The transmission system is simple, uncomplicated and extremely robust. Two gear levers control the high/low speed ranges and the gear selection respectively.

B.M.C. NUFFIELD GROUND SPEED BAR CHART 3/45 AND 4/65



GROUND SPEEDS 800/2200 R.P.M. 1800/2200 INDICATED IN SOLID
P.T.O. SPEED 540 AT 1813 R.P.M.

3/45 (with 11 in. x 28 in. tyres) shown in BLACK 4/65 (with 11 in. x 36 in. tyres) shown in RED

BMC Nuffield independent P.T.O.

First in the U.K. to employ I.P.T.O., the Nuffield system still leads in efficiency of design and operation. Power is transmitted to the tractor rear wheels and to the I.P.T.O. shaft via entirely independent shafts and clutches: the main tractor drive clutch is foot-operated in the normal manner; the I.P.T.O. clutch is hand-operated by lever. This system is ideal in that it permits non-stop headland

turns with the many power-driven implements requiring a temporary interruption of the I.P.T.O. drive during the turn. Stops, starts and gear changes, up or down, may be made without stopping the I.P.T.O. shaft. The I.P.T.O. shaft on a Nuffield, can of course, be stopped without halting the tractor. The Nuffield independent power take-off system has been perfected over the years to a pitch of exceptional reliability in the field.

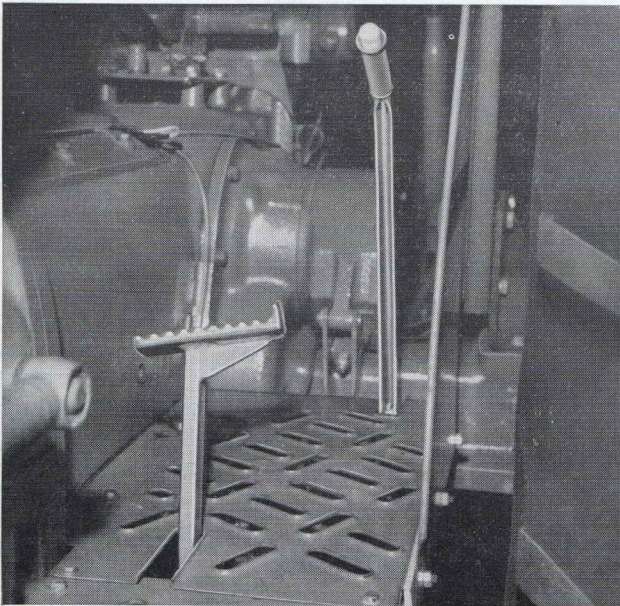

The hand-lever which controls the independent power take-off clutch is controlled by the left hand. A quick-release ratchet holds the clutch lever in the disengaged position.

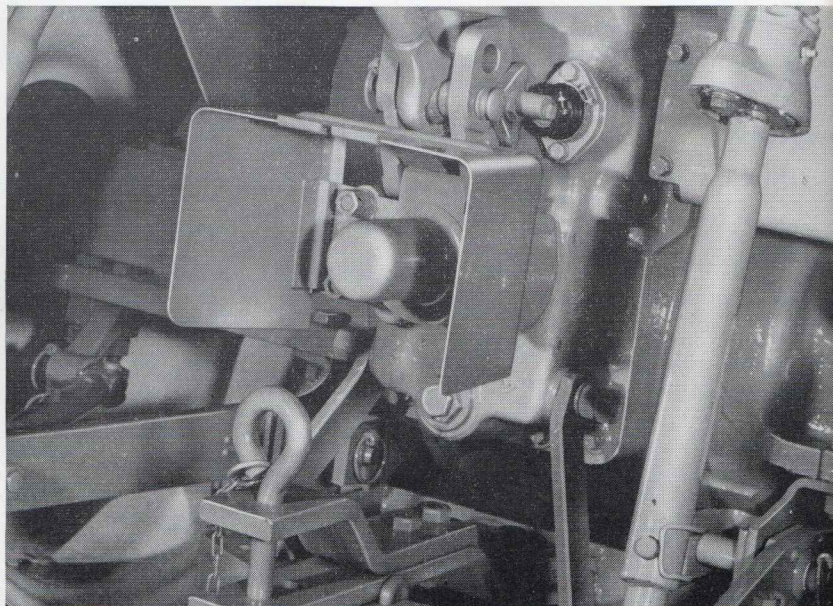

Safety guards provided for the P.T.O. shaft are of heavy gauge steel. In addition to meeting the requirements of the safety regulations, the cover protects the shaft from dirt and corrosion.



more of everything drivers and farmers need

track adjustment

To suit all working conditions wheel tracks are widely adjustable. The range of adjustments shown in the diagrams are applicable to both the Nuffield 3/45 and 4/65 models for front and rear wheels. The range of adjustment for rear wheels with sliding hubs (optional extra) applies only to the 4/65 model.

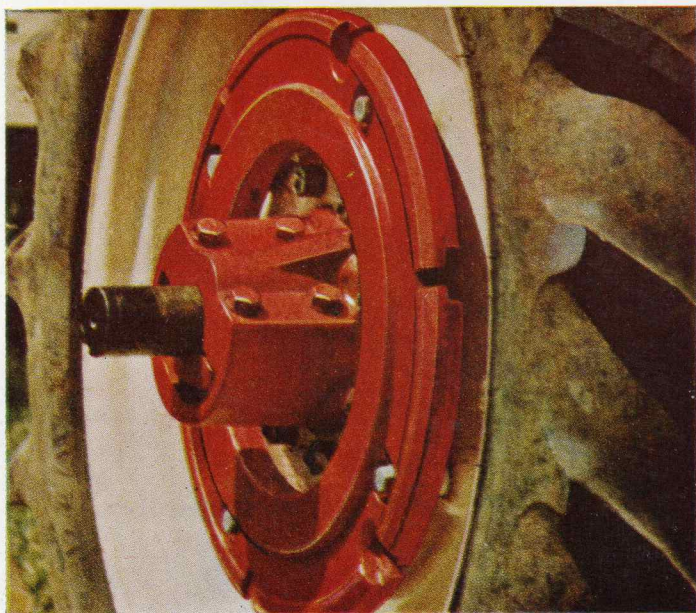

Above: Nuffield sliding rear wheel hubs and extended axles are a popular optional extra (4/65 only). These sliding hubs allow a wide range of adjustment to the rear track without steps.

The extensible track rod is provided with clamp bolts and notches for quick adjustment.

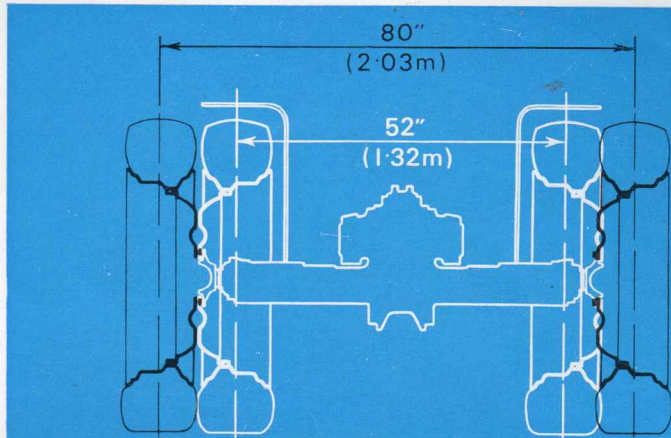
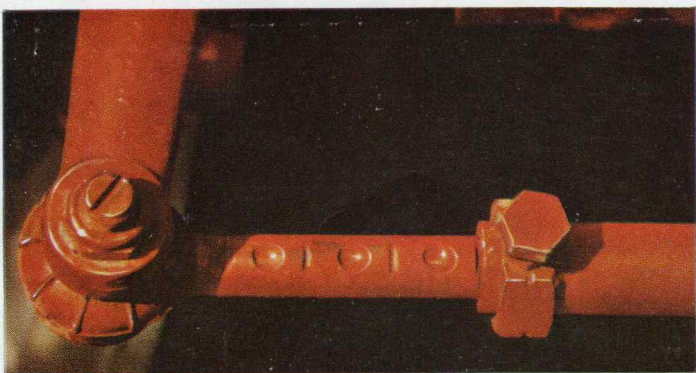

BMC NUFFIELD 3/45 and 4/65 Rear wheels (flanged axles). The track may be varied from 52 in. (1.32 m.) to 80 in. (2.03 m.) (66 in. [1.67 m.] when 14-00—30 or 15-00—30 tyres are fitted) in eight settings of 4 in. (10 cm.).

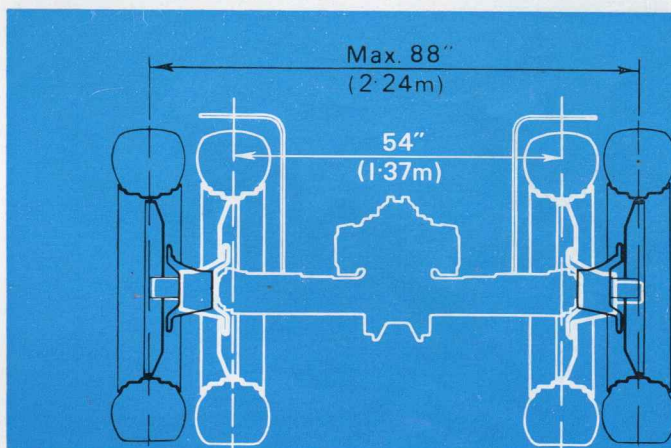

BMC NUFFIELD 4/65 Rear wheels (sliding hubs, 4/65 only). Rear track variations from 54 in. (1.37 m.) to 88 in. (2.24 m.) can be made by a combination of hub movements, wheel 'dish' and hub reversals.

BMC NUFFIELD 3/45 and 4/65 The front axle is adjustable, giving nine track settings from 52 in. (1.32 m.) to 68 in. (1.73 m.) in 2 in. (5 cm.) steps. By reversing the wheels on the hubs a maximum front track of 76 in. (1.93 m.) can be achieved.

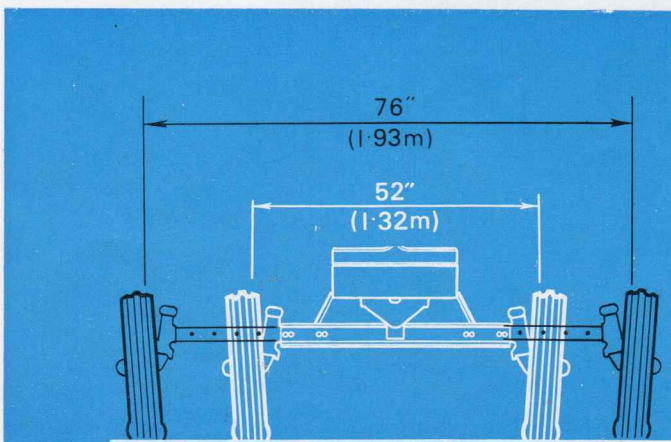

BMC NUFFIELD 3/45 and 4/65 take category 1 & 2 implements



Dual hitch points for the lower draft links provide correct convergence and efficient self-centring with either Category 1 or 2 implements. The draft link check-struts are adjustable to limit or restrict lateral movement of the implement and have two positions for stop pins.

Detachable ball ends (in two pin sizes) snap into the draft link end cages. A double-diameter pin and bush is used in the top link. Implements of both categories are thus fully catered for.

The Nuffield swinging drawbar is made in high-tensile steel. The hitch bracket is reversible, giving a range of hitch points at alter-

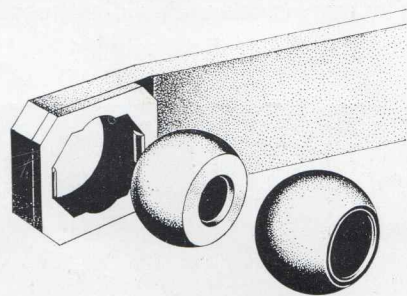

native heights. The hitch bracket has a swing of 14½ in. (26.8 cm.) and can be limited or locked by stop pins. A drawbar extension is provided for use with P.T.O.-driven trailed implements.

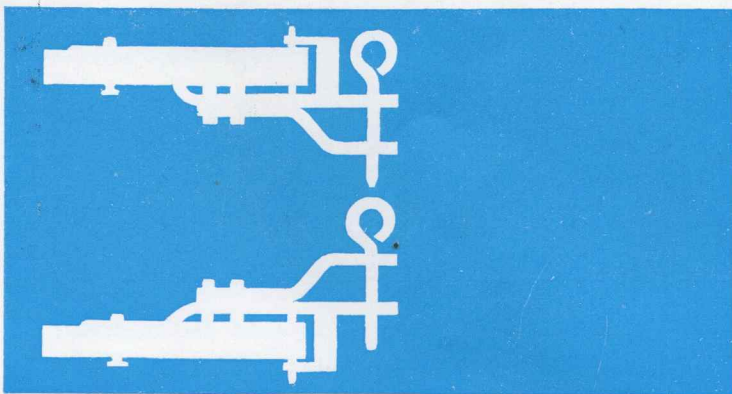

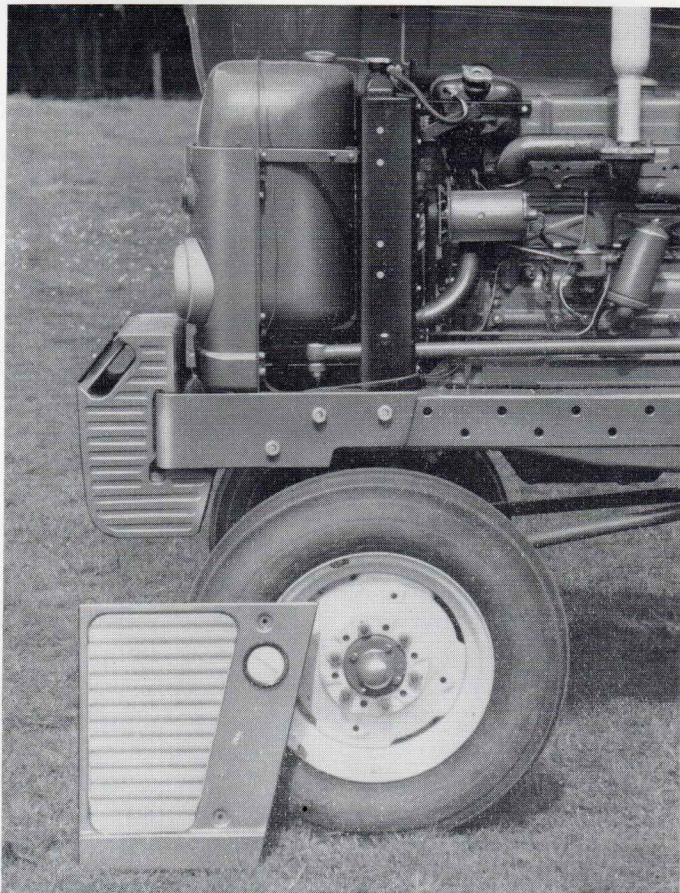

Eight 'hook-on' weights of new design (optional extra) enable front ballast to be easily added or removed. This provision is in addition to internal and external front wheel weights (optional extras). Rear wheel weights (optional extras) are also available. Removable panels in the front end cowling of the 3/45 and 4/65 give access to the fuel tank compartment. The main frame of immense strength is an important Nuffield feature. This frame relieves the power unit of external torsional stresses and provides side mounting points for implements.

The steering drag link, which lies within the limits of the main frame, operates a centrally mounted steering-arm. The entire assembly is out of harm's way and facilitates the mounting of front implements. Apart from adjustment to the notched track-rods (previously described) no other adjustment to the steering layout is required during front track changes. The engine cooling system is of the sealed and pressurized type with radiator and expansion tank. Cooling is assisted by fan and water pump. A temperature gauge is fitted and a thermostat ensures rapid warm-up. The system reduces the necessity for frequent topping up. Both the 3/45 and 4/65 take a rear-mounted belt-pulley (optional extra). This assembly can be fitted in either right- or left-hand positions on the P.T.O. shaft.

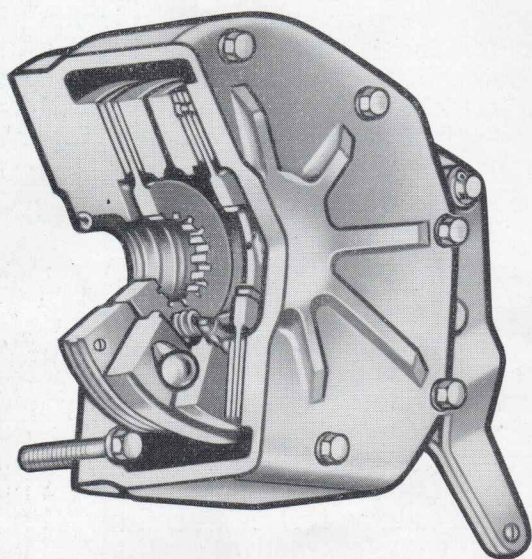

Sectioned Nuffield disc brake.

Twin disc brakes are mounted inboard on the rear axle drive shafts on both the 3/45 and 4/65 models.

Radius rods are fitted between the outer ends of the front axle beam and a pivot point beneath the rear of the main frame.

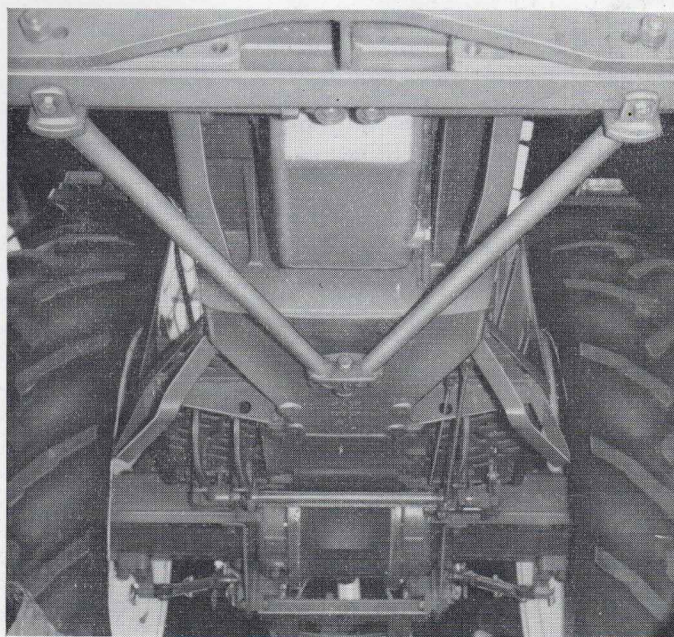

WEIGHTS: Basic model plus oils, fuel, and water: 4,045 lb. (1834.8 kg.); Standard model including hydraulic power unit, electric lighting, horn, plus oils, fuel, and water, with 11.00—28 tyres: 4,460 lb. (2023 kg.); De-luxe model as standard but including independent power take-off: 4,610 lb. (2091 kg.).

ENGINE: Compression ignition, direct-injection type. Three cylinders; overhead valve; bore and stroke 100 mm. x 120 mm. (3.94 in. x 4.724 in.); cubic capacity 2827 c.c. (172.5 cu. in.); compression ratio 16.5 : 1; 45 b.h.p. at 2,200 engine r.p.m. Cylinder block and crankcase is a one-piece casting. Detachable, wet cylinder liners. Cavity-type aluminium-alloy pistons with three compression and two scraper rings. Four-bearing crankshaft mounted in copper-lead shells. Camshaft is driven through nickel-chrome helical gears. High-pressure forced lubrication throughout engine. A large oil-bath or dry air cleaner is incorporated in the air intake.

COOLING: By centrifugal pump with a two-bladed fan mounted on the rotor spindle. The water circulation is thermostatically controlled and a temperature gauge is provided. The radiator is protected by a robust pressed-steel cowl.

FUEL SYSTEM: Fuel is fed to the injector pump by an A.C.-type lift pump operated by the camshaft. Tank capacity is 15 gallons (68.25 litres).

FUEL INJECTION PUMP: Of Simms design, incorporating a mechanical governor giving constant engine speed under varying load.

CLUTCH: Standard 11 in. (28 cm.) diameter single dry plate Borg & Beck type, requiring no internal lubrication or adjustment. With independent P.T.O. Borg & Beck 11 in. (28 cm.) double clutch.

GEARBOX AND DIFFERENTIAL:

Gearbox Ratios

Low	1st	47/14 x 46/16	9.65 : 1
High	1st	45/17 x 46/16	7.61 : 1
Low	2nd	47/14 x 40/22	6.11 : 1
High	2nd	45/17 x 40/22	4.81 : 1
Low	3rd	47/14 x 33/29	3.82 : 1
High	3rd	45/17 x 33/29	3.01 : 1
Low	4th	47/14 x 24/38	2.12 : 1
High	4th	45/17 x 24/38	1.67 : 1
Low	5th	1 : 1	1 : 1
High	5th	45/17 x 14/47	0.79 : 1
Low Rev.		47/14 x 13/29 x 46/21	3.30 : 1
High Rev.		45/17 x 13/29 x 46/21	2.60 : 1
Differential Ratio			4.38 : 1

FINAL DRIVE: By spiral bevel gears and heavy-duty spur gears. Overall ratio 18.4 : 1. Oil capacity of transmission, 12 gallons (54.5 litres).

ELECTRICAL EQUIPMENT: Lucas HV17A 12 V. battery; Lucas pre-engaged-type starter motor; dynamo and control box; twin dipping headlamps; side and tail lamps; horn and ploughing lamp.

EASY-STARTING DEVICE: A manually-operated excess fuel device is incorporated in the Simms injector pump unit.

STEERING AND FRONT AXLE: 16 in. (40.6 cm.) diameter steering-wheel. High-efficiency screw and roller type gear. 3.7 turns from lock to lock. Power-assisted steering is available at extra cost. Front axle designed with centre-point steering giving light and strong self-centring action.

INSTRUMENTS: The instrument panel is housed immediately forward of the steering-wheel and includes a large tractometer, water temperature, oil pressure, fuel and battery condition gauges.

HYDRAULICS: System pressures: main lift and auxiliary circuit 2,300 to 2,600 p.s.i.; depth control circuit, 1,900 to 2,100 p.s.i. Pump output: main lift and auxiliary pump 6½ g.p.m. at 2,200 engine r.p.m.; depth control pump 1½ g.p.m. controlled flow at 1,200 engine r.p.m. and above. Valve gear includes twin spool valve to give independent operation of tractor linkage and auxiliary equipment; depth control valve operated manually by depth control lever and automatically by load variation in the top link. Perfect filtration is ensured by a 150 sq. in. x 100 mesh strainer installed in the pump inlet; a secondary 15 sq. in. x 32 mesh strainer is included through which oil is filtered via a by-pass valve for cold-start conditions.

DISC BRAKES: Self-energizing independent disc-type steering brakes, 6½ in. (16.5 cm.) diameter.

WHEEL EQUIPMENT:

		<i>Tyre Size</i>
Front tyres (standard)	4-ply	5.50—16
Front tyres (alternative)	6-ply	6.00—16
Front tyres (alternative)	6-ply	7.50—16
Rear tyres (standard)	6-ply	11.00—28
Rear tyres (alternative)	6-ply	11.00—32
Rear tyres (alternative)	6-ply	13.00—28
Twin rear tyres (alternative)	6-ply	11.00—28
Twin rear tyres (alternative)	6-ply	11.00—32

ADDITIONAL WEIGHTS: To cope with the varying loads imposed by a wide range of front-, mid-, and rear-mounted implements in current use, additional weights are available as optional equipment. To increase front end weight, hook-on hand weights are available up to a maximum of eight, giving a maximum additional load of 700 lb. approximately. Front wheel weights inner and outer are available supplied in pairs, at 100 lb. (45.3 kg.) each. Rear wheel weights 100 lb. (45.3 kg.) each, supplied in pairs.

BMC NUFFIELD 4/65

WEIGHTS: Basic model plus oils, fuel, and water: 4,780 lb. (2168.2 kg.); Standard model including hydraulic power unit, electric lighting, horn, plus oils, fuel, and water with 11.00—36 tyres: 5,140 lb. (2330.5 kg.); De-luxe model as standard but including independent power take-off; 5,290 lb. (2398.5 kg.).

ENGINE: Compression ignition, direct-injection type. Four cylinders; overhead valve; bore and stroke 100 mm. x 120 mm. (3.94 in. x 4.724 in.), cubic capacity 3770 c.c. (230 cu. in.); compression ratio 16.5 : 1; 65 b.h.p. at 2,500 engine r.p.m. Cylinder block and crankcase is a one-piece casting. Detachable, wet cylinder liners. Cavity-type aluminium-alloy pistons with three compression and two scraper rings. Five-bearing crankshaft. Camshaft is driven through nickel-chrome helical gears. High-pressure forced lubrication throughout engine. A large oil-bath or dry air cleaner is incorporated in the air intake.

COOLING: By centrifugal pump and a two-bladed fan, belt driven from a pulley on the crankshaft. A temperature gauge is provided and a thermostat is fitted to ensure rapid warm-up. The radiator is protected by a robust, pressed-steel cowl.

FUEL SYSTEM: Fuel is fed to the injector pump by an A.C.-type lift pump operated by the camshaft. Tank capacity is 15 gallons (68.25 litres).

FUEL INJECTION PUMP: Of Simms design incorporating a mechanical governor giving constant engine speed under varying load.

CLUTCH: 11 in. (28 cm.) diameter single dry plate Borg & Beck type, requiring no internal lubrication or adjustment. With independent P.T.O. Borg & Beck 11 in. (28 cm.) double clutch.

GEARBOX AND DIFFERENTIAL:

Gearbox Ratios

Low	1st	47/14 x 46/16	9.65 : 1
High	1st	45/17 x 46/16	7.61 : 1
Low	2nd	47/14 x 40/22	6.11 : 1
High	2nd	45/17 x 40/22	4.81 : 1
Low	3rd	47/14 x 33/29	3.82 : 1
High	3rd	45/17 x 33/29	3.01 : 1
Low	4th	47/14 x 24/38	2.12 : 1
High	4th	45/17 x 24/38	1.67 : 1
Low	5th	1 : 1	1 : 1
High	5th	45/17 x 14/47	0.79 : 1
Low Rev.		47/14 x 13/29 x 46/21	3.30 : 1
High Rev.		45/17 x 13/29 x 46/21	2.60 : 1
Differential Ratio			4.38 : 1

FINAL DRIVE: By spiral bevel gears and heavy-duty spur gears. Overall ratio 18.4 : 1. Oil capacity of transmission, 12 gallons (54.5 litres).

ELECTRICAL EQUIPMENT: Lucas 12-volt THV17A battery; pre-engaged type starter motor; dynamo and control box; twin dipping headlamps; side and tail lamps; horn and ploughing lamp.

EASY-STARTING DEVICE: A manually-operated excess fuel device is incorporated in the Simms injector pump unit.

STEERING AND FRONT AXLE: 16 in. (40.6 cm.) diameter steering-wheel. High-efficiency screw and roller type gear. 3.7 turns from lock to lock. Power-assisted steering available at extra cost. Front axle designed with centre-point steering giving light and strong self-centring action.

INSTRUMENTS: The instrument panel is housed immediately forward of the steering-wheel and includes a large tractometer, water temperature, oil pressure, fuel and battery condition gauges.

HYDRAULICS: System pressures: main lift and auxiliary circuit 2,300 to 2,600 p.s.i.; depth control circuit, 1,900 to 2,100 p.s.i. Pump output: main lift and auxiliary pump 6½ g.p.m. at 2,200 engine r.p.m.; depth control pump 1½ g.p.m. controlled flow at 1,200 engine r.p.m. and above. Valve gear includes twin spool valve to give independent operation of tractor linkage and auxiliary equipment; depth control valve operated manually by depth control lever and automatically by load variation in the top link. Perfect filtration is ensured by a 150 sq. in. x 100 mesh strainer installed in the pump inlet; a secondary 15 sq. in. x 32 mesh strainer is included through which oil is filtered via a by-pass valve for cold-start conditions.

DISC BRAKES: Self-energizing independent disc-type steering brakes, 6½ in. (16.5 cm.) diameter.

WHEEL EQUIPMENT:

	<i>Tyre Size</i>
Front tyres (standard)	6-ply 6.00—16
Front tyres (alternative)	6-ply 7.50—16
Rear tyres (standard)	6-ply 11.00—36
Rear tyres (alternative)	6-ply 12.00—38
Rear tyres (alternative)	6-ply 14.00—30
Rear tyres (alternative)	8-ply 14.00—30
Rear tyres (alternative)	8-ply 15.00—30
Twin rear tyres (alternative)	6-ply 11.00—36
Universal tread tyres (alternative)	6-ply 11.00—36
Universal tread tyres (alternative)	8-ply 14.00—30

ADDITIONAL WEIGHTS: To cope with the varying loads imposed by a wide range of front-, mid-, and rear-mounted implements in current use, additional weights are available as optional equipment. To increase front end weight, hook-on hand weights are available up to a maximum of eight, giving a maximum additional load of 700 lb. approximately. Front wheel weights inner and outer are available supplied in pairs, at 100 lb. (45.3 kg.) each. Rear wheel weights which are each 110 lb. (50 kg.) supplied in pairs.

EXTENDED REAR AXLES: (optional extra), sliding hubs for quick and easy adjustment of track settings, are available as an alternative to the standard flanged-type axle.

BMC NUFFIELD 3/45

BMC NUFFIELD 4/65

Basic Model

Equipment includes differential lock; hand brake; full instrumentation; front weight carrier; swinging drawbar; disc-type steering brakes; licence holder; radius rods; 5.50—16 (4-ply) front tyres; 11.00—28 (6-ply) rear tyres.

Standard Model

Equipment as on Basic Model plus hydraulic power unit and three-point linkage (Cat. 1 & 2), independent hydraulics and automatic draught control. P.T.O. and safety guards, drawbar extension, electric lighting with twin dipping head-lamps, side and tail lamps, ploughing lamp, horn and number-plates.

De-luxe Model

Equipment as on Standard Model but including independent P.T.O.

Basic Model

Equipment includes differential lock; hand brake; full instrumentation; front weight carrier; swinging drawbar; disc-type steering brakes; licence holder; radius rods; 6.00—16 (6-ply) front tyres; 11.00—36 (6-ply) rear tyres.

Standard Model

Equipment as on Basic Model plus hydraulic power unit and three-point linkage (Cat. 1 & 2), independent hydraulics and automatic draught control. P.T.O. and safety guards, drawbar extension; electric lighting with twin dipping head-lamps, side and tail lamps, ploughing lamp, horn and number-plates.

De-luxe Model

Equipment as on Standard Model but including independent P.T.O.

optional equipment

Belt pulley and guard
Rear wheel weights
Front wheel weights (outer)
Front wheel weights (inner)
Front end weights (set of 8)

Power-assisted steering
13 in. heavy-duty clutch (Basic and Standard Models only)
De-luxe hydraulic suspension seat
Extended axles and sliding hubs (4/65 only)
Additional independent wheel brakes

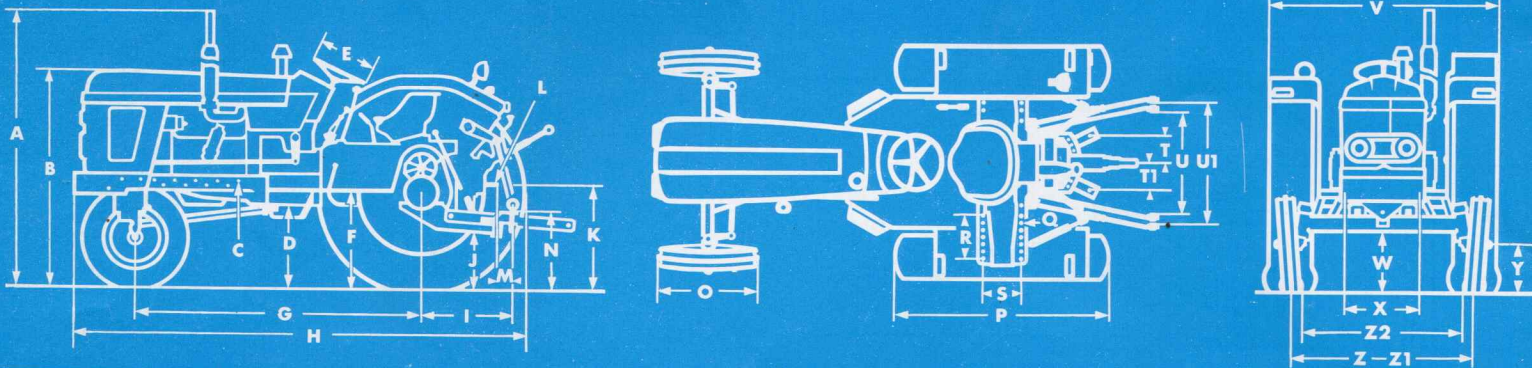

dimensions

	3/45	4/65		3/45	4/65		
A	Overall height	6' 10 $\frac{3}{4}$ " (2.10 m.)	7' 2 $\frac{3}{4}$ " (2.2 m.)	S	Distance between attachment holes across rear axle	10 $\frac{1}{2}$ " (26.67 cm.)	10 $\frac{1}{2}$ " (26.67 cm.)
B	Height—ground to bonnet top	4' 9" (1.44 m.)	5' 1" (1.54 m.)	T	Drawbar swing—R.H.	7 $\frac{1}{2}$ " (18.41 cm.)*	7 $\frac{1}{2}$ " (18.41 cm.)*
C	Implement attachment points	(18 holes) $\frac{3}{8}$ " (1.98 cm.) dia.	(18 holes) $\frac{3}{8}$ " (1.98 cm.) dia.	T1	Drawbar swing—L.H.	7 $\frac{1}{2}$ " (18.41 cm.)*	7 $\frac{1}{2}$ " (18.41 cm.)*
D	Height—ground to bottom of chassis frame	1' 7 $\frac{3}{8}$ " (48.57 cm.)	1' 11 $\frac{1}{8}$ " (58.73 cm.)	U	Hitch points conform to B.S.S. 1841 1951 Category 1	2' 2 $\frac{7}{8}$ " (68.26 cm.)	2' 2 $\frac{7}{8}$ " (68.26 cm.)
E	Steering-wheel diameter	1' 4" (40.64 cm.)	1' 4" (40.64 cm.)	U1	Hitch points conform to B.S.S. 1841 1951 Category 2	2' 8 $\frac{1}{16}$ " (82.39 cm.)	2' 8 $\frac{1}{16}$ " (82.39 cm.)
F	Height—ground to footplate	1' 11 $\frac{7}{8}$ " (60.64 cm.)	2' 3 $\frac{3}{8}$ " (70.48 cm.)	V	Overall width	5' 8" (1.72 m.) at 4' 8" (1.42 m.) track	5' 8" (1.72 m.) at 4' 8" (1.42 m.) track
G	Wheelbase	6' 3" (1.90 m.)	6' 8 $\frac{1}{2}$ " (2.03 m.)	W	Height—ground to underside of front axle	1' 4 $\frac{1}{8}$ " (40.95 cm.)	1' 5 $\frac{3}{8}$ " (43.65 cm.)
H	Overall length	9' 9 $\frac{1}{4}$ " (2.97 m.)	10' 6 $\frac{1}{2}$ " (3.21 m.)	X	Width of frame	1' 9 $\frac{3}{8}$ " (54.29 cm.)	1' 9 $\frac{3}{8}$ " (54.29 cm.)
I	Centre of rear axle to drawbar hitch pin	2' 1" (63.50 cm.)	2' 1" (63.50 cm.)	Y	Height—ground to centre of front hub	1' 0 $\frac{7}{8}$ " (31.43 cm.)	1' 1 $\frac{1}{8}$ " (34.29 cm.)
J	Height—ground to underside of drawbar	1' 1 $\frac{3}{8}$ " (33.97 cm.)	1' 3 $\frac{1}{2}$ " (38.73 cm.)	Z	Track—rear	4' 4" to 6' 8" (1.32 m. to 2.03 m.)	4' 4" to 6' 8" (1.32 m. to 2.03 m.)†
K	Height—ground to P.T.O. shaft	2' 1 $\frac{1}{2}$ " (64.77 cm.)	2' 5 $\frac{1}{2}$ " (74.93 cm.)	Z1	Track—front	4' 4" to 6' 4" (1.32 m. to 1.93 m.)	4' 4" to 6' 4" (1.32 m. to 1.93 m.)
L	P.T.O. shaft diameter	1 $\frac{3}{8}$ " (3.49 cm.)	1 $\frac{3}{8}$ " (3.49 cm.)	Z2	Distance between inner edge of front tyres at ground	3' 10" (1.16 m.)	3' 9 $\frac{3}{4}$ " (1.15 m.)
M	End of P.T.O. shaft to drawbar hitch pin	3 $\frac{3}{8}$ " (7.93 cm.)*	3 $\frac{3}{8}$ " (7.93 cm.)*				
N	Height of hitching point (min.)	1' 2" (35.56 cm.)†	1' 2" (35.56 cm.)†				
	Height of hitching point (max.)	10 $\frac{1}{8}$ " (25.71 cm.)	11 $\frac{3}{8}$ " (29.84 cm.)				
O	Diameter of front wheels	1' 7 $\frac{1}{8}$ " (48.57 cm.)	1' 9 $\frac{3}{8}$ " (55.24 cm.)				
P	Diameter of rear wheels	2' 3 $\frac{1}{8}$ " (69.85 cm.)	2' 5 $\frac{1}{8}$ " (73.97 cm.)				
Q	No. of attachment holes in rear axle case	4' 2 $\frac{1}{2}$ " (1.28 m.)	4' 10 $\frac{1}{16}$ " (1.48 m.)				
R	Maximum width attachment holes for implements—rear axle	14	14				
		1' (30.48 cm.)	1' (30.48 cm.)				

* Standard † Extension ‡ Sliding Hubs



export availability

Tractors are available built to standard or de-luxe specification.

For customers requiring the Home Market Basic model the standard model can be supplied to a reduced specification.

Optional Extras available include all those normally supplied to the Home Market, plus electrical equipment to suit local conditions; fifth speed excluder to limit road speed; 96 amp.-hr. cold start battery (3/45 only); P.A.V.T. (Power-assisted variable-track) wheels.

BMC Nuffield 3/45 and 4/65 tractors are produced at the large, modern BMC factory at Bathgate, Scotland. Engines and transmissions are made and assembled on the site. Flow production, automation, and quality control ensure high standards and reduce costs.

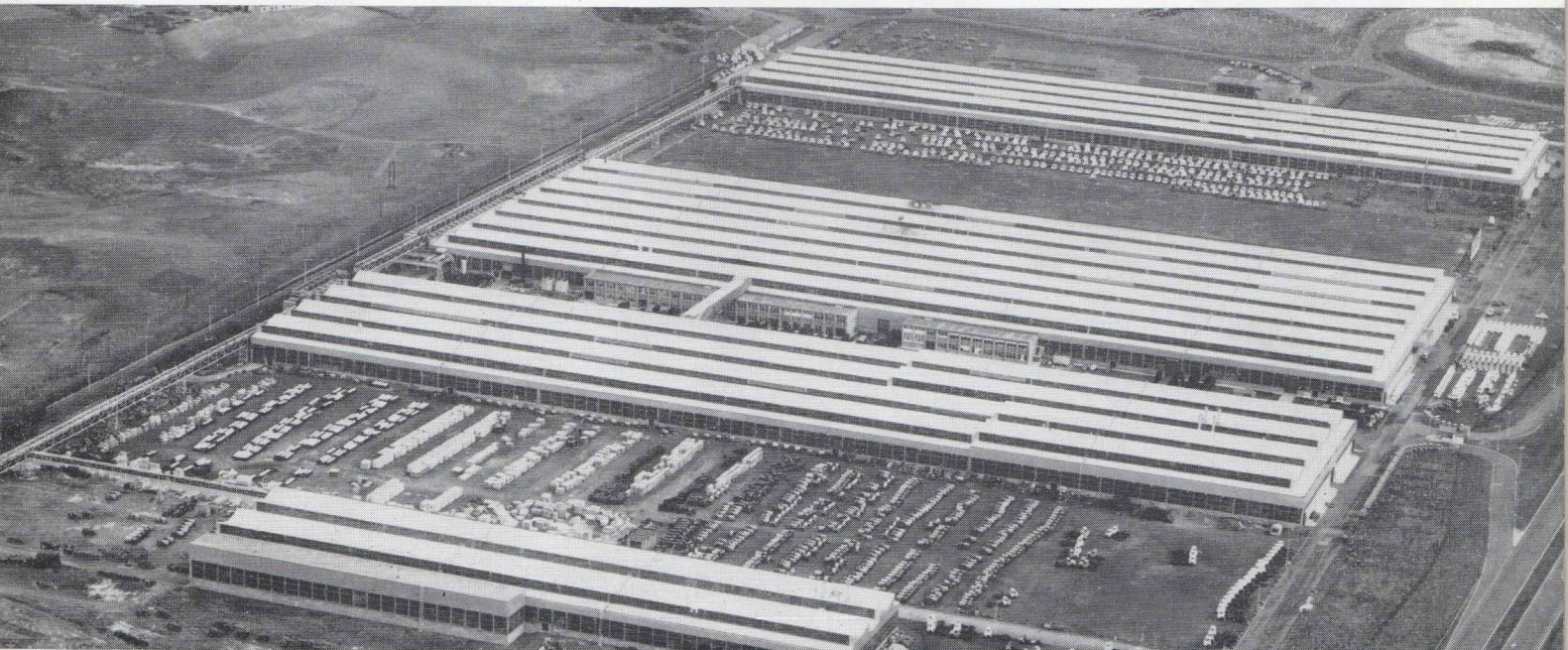

The issue of this publication does not constitute an offer, and the right is reserved to alter specifications at anytime without notice. Sales are made subject to and with the benefit of the standard Conditions of Sales and Warranty given by the Distributor or Dealer by agreement with The British Motor Corporation Limited.



THE **BRITISH** MOTOR CORPORATION LIMITED
BIRMINGHAM AND OXFORD, ENGLAND