

New!

Holder
1888

Cultitrac AG 35

The new Holder AG 35 Four-wheel Drive Tractor with narrow track, standard track and standard three-point hydraulics. The ideal machine for vineyards and hop gardens, mountain farms, orchards, citrus plantations, agriculture, forestry and local authorities.

AGRICULTURAL
ENGINEERING
6 NOV 1969
LINCOLN COLLEGE



Holder - For 80 years in the service of agriculture

Four wheel Drive Tractor Model

27 DIN HP — 31 SAE HP

with hydromatic steering



This is the Holder AG35 Four-wheel Drive Tractor. A new development in the world famous Holder "Cultitrac" range. The tractor is equipped with four-wheel drive, even weight distribution, four equal wheels, a low centre of gravity with a large ground clearance resulting in a complete absence of wheel-slip. The AG 35 masters easily and safely the most difficult jobs.

The pivotal hydraulically operated steering, effective on all four wheels, makes for particular comfort. It allows the machine to be easily steered. The ingenious construction makes steering brakes superfluous.

The AG 35 is powered by a smooth and quiet running, highly resilient three-cylinder diesel engine. The particularly flat top of the engine cover allows for easy access. The water cooling with thermostatically controlled pump assures the right operation temperatures under all climatic conditions.

The robust, powerful and manoeuvrable Holder four-wheel drive tractors have proved reliable all over the world and are suitable for all types of work. The tractor has a wide range of hydraulic points allowing the attachment of all implements for agriculture, forestry and local service.

A demonstration — without any obligation — will convince you.

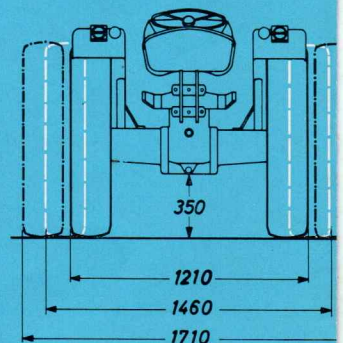
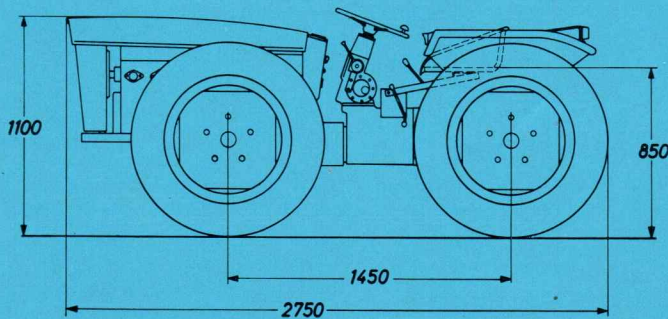
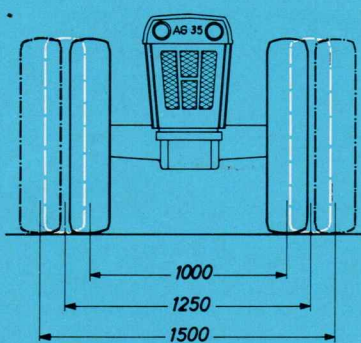

Model AG 35

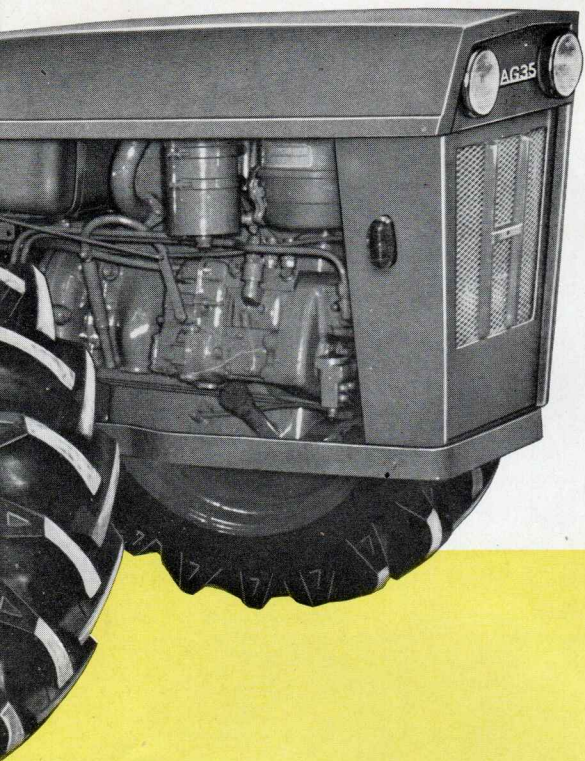

The AG 35 has narrow and standard track and standard three-point hitch for use on the steepest inclines and its steering accuracy is unsurpassed. It provides maximum drawbar pull under the worst conditions with complete ease. The machine to be steered and turned on the smallest space with one hand. The torque characteristic gives good acceleration and high capacity. It performs well in all conditions and increases the service life of the engine. It is suitable for use under any climatic condition. The new AG 35 has standard three-



AG 35 with hay lift in the mountains



AG 35 with snow clearing blade



AG 35 with rotary cultivator



AG 35 in forestry

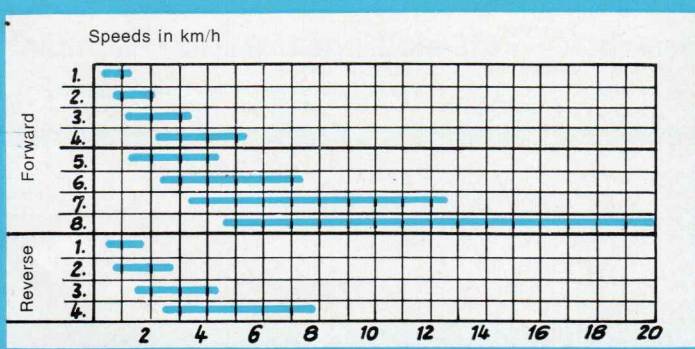

Technical data: (standard equipment)

311130

Construction: Strong, frameless unit construction. Four-wheel drive. Brakes and steering effective on all four wheels. Adjustable mudguards.

Water-cooled Diesel Engine: 1500 cc, three-cylinder, 30 DIN HP (34 SAE HP) at 2300 rpm, water-cooled with thermostatically controlled pump. Easy starting from cold. Bosch fuel injection system and governor. Low consumption through direct fuel injection. Smooth and quiet running. Quick response acceleration. Engine components designed for long life and minimum service attention. Particularly flat torque characteristic giving high capacity even at medium revs. Crankshaft on four ball bearings. Particularly quiet running — 76 some only — according to O.E.C.D. Test.

Tank: 23 litres (approx. 5 galls.) Built-in micronic filter.

Air filter: Large oil-bath wire gauze type, with cyclone preselector.
Clutch: single plate dry clutch.

Transmission: 8 forward gears (0,5–20 km/h — 0.25–12.4 mph) and 4 reverse gears. (See speed chart — values refer to km/h — 1 mile = 1,609 km). Drive from engine is taken by splined propeller shaft and universal joints through gearbox to rear differential, returning to front axle via twin propeller shaft. Pedal-operated front wheel diff-lock.

Tyres: 8x24 AS (4 ply rating), or 10.5x20 AS (6 ply rating)

P.T.O.: 590 rpm at 2300 engine revs. Standard splined shaft 1^{3/8}". Independent of transmission.

Steering: Hydraulically operated pivotal steering, effective on all four wheels (ZF hydromatic steering).

Brakes: Internal expanding shoe and drum type. Foot pedal operates rear wheel brakes. Hand ratchet lever operates front wheel brakes for parking. Both brakes act independently on all four wheels through the transmission.

Trailer hitch: Revolving and adjustable for height with strong guard forged in one piece.

Hydraulics: standard equipment. Consisting of Bosch hydraulic pump and control valve, lifting cylinder, shaft, pipes etc. Up-to-date arrangement. Lifting capacity 600 kpm.

Implement lift: Standard three-point linkage with field bar. Cat. I — DIN 9674 (DIN = German specification standards).

Electrical equipment: 12 Volt system, Bosch Dynamo and starter, battery, 2 headlights, 2 front and 2 rear traffic indicators, 2 rear reflectors, 2 brake lights, licence plate light, horn, glow plug, fuse box, socket for two trailer and traffic lights.

Tractormeter: showing ground speed, engine and p.t.o rpm, and hours.

Tool box with tools.

Weight: 1240 kg (2728 lbs.)

Forestry version available with 10.5x20 AS (6 ply) tyres.

We reserve the right to make alterations in design serving technical improvement.

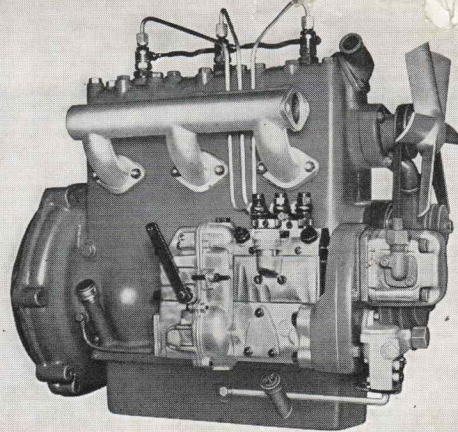

Holder three-cylinder diesel engine, 1500 cc, water-cooled. Robust, resilient, powerful and economic. Easy to start — smooth and quiet running — requires minimum service attention.



Easily accessible — radiator, air filter, hydraulics, oil tank, fuel tank, tool box, battery, wiring. Dials and controls clearly arranged.

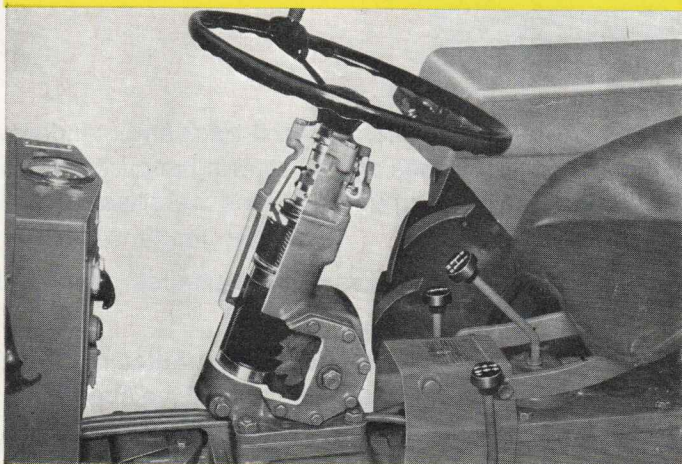

Comfortable driving is no luxury. Owing to the hydraulically operated steering, effective on all four wheels, the machine is easily and safely steered in most difficult terrain. ZF hydromatic steering shown in illustration.

GEBRÜDER HOLDER · Maschinenfabrik · 7418 Metzingen/Württ. · Germany

Phone: (071 23) 2036*

Telex: 07 29 419

Cables: Holder Metzingenwuertt.

Information - Sales:

2.000 E - 28. 3. 69 - L + Sch

HOLDER LEADS THE FIELD